

SNR Gehäuselager mit Guss- oder Stahlblech-Gehäusen





SNR Gehäuselager – mehr als nur Standard

Mehr als nur Standard - das sind für uns nicht nur Worte! Seit mehr als 35 Jahren ist SNR ein führender Hersteller von Gehäuselagern und verfügt somit über große Erfahrungen bei den verschiedensten Anwendungen im Maschinen- und Anlagenbau.

Neben dem umfangreichen Standard-Programm hat SNR eine Vielzahl von kundenbezogenen Sonderlösungen entwickelt.

Dabei handelt es sich um verschiedene Oberflächenbehandlungen, wie z.B. Sonderlackierungen, Verzinken oder Vernickeln, unterschiedliche Befestigungs- oder Dichtungssysteme an den Einsätzen, Sonderabmessungen, aber auch neue Gehäusebauformen – eben mehr als nur Standard.

Im vorliegenden Katalog finden Sie unser SNR-Standard-Programm für Gehäuselager mit Guss- oder Stahlblech-Gehäusen.

Die Gehäuse sind aus Grauguss oder Stahlblech gefertigt. Um die Oberflächen der Gussgehäuse vor Korrosion zu schützen, werden sie passiviert und anschließend lackiert. Alle Stahlblech-Gehäuse sind verzinkt.

Die SNR-Lager-Einsätze aus Wälzlagerstahl verfügen über geschmiedete Ringe. Diese Art der Formgebung wirkt sich günstig auf die Lebensdauer der Lager aus.

Sie sind als Rillenkugellager mit sphärischen Außenringen ausgeführt, die Fluchtungsfehler der Lagerstellen und Durchbiegungen der Wellen in bestimmtem Umfang ausgleichen können. Die

Befestigung auf der Welle erfolgt mittels Gewindestiften, Exzentreringen oder Spannhülsen. SNR bietet aber auch die Möglichkeit, die Lagerstellen als Loslager auszuführen.

Für besonders schwierige Umgebungsbedingungen stehen Lagereinsätze mit der dreilippigen Dichtung L3 zur Verfügung.

Zusätzlich besteht die Möglichkeit, Grauguss-Gehäuseeinheiten mit offenen oder geschlossenen Schutzkappen aus rostfreiem Stahl zu versehen.

Das SNR-Standard-Programm umfasst auch Gehäuselager in Hoch- und Tieftemperatur-Ausführung.

Reicht die Belastbarkeit bei den Einheiten der Baureihen 200 nicht aus, kann der Konstrukteur auf die verschiedenen Gehäuselager der Reihen 300 zurückgreifen. Auch dafür stehen unterschiedliche Befestigungsmöglichkeiten auf der Welle zur Verfügung.

Sollte der Anwender nicht das für seinen Fall optimale Bauteil in diesem Katalog oder in den Katalogen „SNR Gehäuselager aus Rostfreiem Stahl“ oder „SNR Rostfreie Gehäuselager mit Thermoplast Gehäusen“ finden, besteht immer noch die Möglichkeit, von SNR eine maßgeschneiderte Lösung zu bekommen.

Bitte wenden Sie sich auch in einem solchen Fall an eines unserer Verkaufsbüros. Spätestens dann werden Sie feststellen:

SNR Gehäuselager - mehr als nur Standard

Inhalt

Seite

1. Allgemeines

Vorwort	2
Übersicht über das Lieferprogramm	4 - 5
Bezeichnungsschema	6
Vor- und Nachsetzzeichen	7
Gehäusebauformen	8 - 9

2. SNR Gehäuselager

Gehäuselager aus Grauguss	
Ausführung	10
Werkstoffe/Oberflächen	11
Belastbarkeit	12 - 13
Gehäuse aus Stahlblech	
Ausführung	14
Werkstoffe/Oberflächen	15
Belastbarkeit	15
Einsätze	
Ausführung	16 - 17
Werkstoffe	18
Möglichkeiten der Wellenbefestigung	19 - 21
Anzugsmomente	22
Abdichtungen	23
Betriebstemperatur	24
Lagerluft	24
Axiale Belastbarkeit der Einsätze	25
Tragfähigkeit und Drehzahlgrenzen	25
Lebensdauerberechnung	26 - 28
Schutzkappen	
Ausführungen	29
Werkstoffe	29
Befestigung am Gehäuse	29
Montage der Schutzkappen	30
Abdichtungen	30
Einheiten	
Ausführungen	31
Montage	31 - 33
Schmierung und Wartung	34 - 35

3. Maßtabellen

Gehäuselager	36 - 159
Einsätze	160 - 183

4. Toleranzen und Gehäusefixierung

Toleranzen der Gehäuse aus Grauguss	184 - 189
Gehäusefixierung	190 - 191
Toleranzen der Gehäuse aus Stahlblech	192
Toleranzen der Einsätze	193 - 195

5. Sondergehäuselager































Sondergehäuselager	196
--------------------	-----

6. Tabellen









Umrechnungstabelle inch - mm	197
Umrechnungstabelle mm - inch	198









Übersicht über das Lieferprogramm Grauguss-Gehäuse der Baureihen 200

	Einsätze Seite	UC200  160	Seite	US200  161	Seite	ES200  162	Seite	EX200  163	Seite	UK200+H  164	Seite	Schutz- kappen	Seite
Stehlagergehäuse	use												
		UCPE	36	USPE	36	ESPE	36	EXPE	36	UKPE+H	36	CO/CC	36
		UCPLE	40	USPLE	40	ESPLE	40	EXPLE	40	UKPLE+H	40	CO/CC	40
		UCP	44	USP	44	ESP	44	EXP	44	UKP+H	44	CO/CC	44
		UCPH	52	USPH	52	ESPH	52	EXPH	52	UKPH+H	52	CO/CC	52
		UCPAE	56	USPAE	56	ESPAE	56	EXPAE	56	UKPAE+H	56	CO/CC	56
		UCPG	60	USPG	60	ESPG	60	EXPG	60	UKPG+H	60	CO/CC	60
	UCPA	64	USPA	64	ESPA	64	EXPA	64	UKPA+H	64			
Flanschlagergehäuse		UCFE	68	USFE	68	ESFE	68	EXFE	68	UKFE+H	68	CO/CC	68
		UCF	72	USF	72	ESF	72	EXF	72	UKF+H	72	CO/CC	72
		UCFCE	80	USFCE	80	ESFCE	80	EXFCE	80	UKFCE+H	80		
		UCFC	84	USFC	84	ESFC	84	EXFC	84	UKFC+H	84	CO/CC	84
				USFEE	88	ESFEE	88						
				USFTE	94	ESFTE	94						
		UCFLE	96	USFLE	96	ESFLE	96	EXFLE	96	UKFLE+H	96	CO/CC	96
		UCFL	100	USFL	100	ESFL	100	EXFL	100	UKFL+H	100	CO/CC	100
		UCFLZ	108	USFLZ	108	ESFLZ	108	EXFLZ	108	UKFLZ+H	108		
				USFD	112	ESFD	112						
				USFAE	114	ESFAE	114						
		UCFA	116	USFA	116	ESFA	116	EXFA	116	UKFA+H	116	CO/CC	116
	Spannplatten-, Hülsen- und Hängelagergehäuse		UCT	120	UST	120	EST	120	EXT	120	UKT+H	120	CO/CC
		UCT+WB	128	UST+WB	128	EST+WB	128	EXT+WB	128	UKT+H+WB	128	CO/CC	128
		UCSP	132	USSP	132	ESSP	132	EXSP	132	UKSP+H	132	CO/CC	132
		1 - 24	136										
		UCC	138	USC	138	ESC	138	EXC	138	UKC+H	138		
	UCEHE	146	USEHE	146	ESEHE	146	EXEHE	146	UKEHE+H	146			



Grauguss-Gehäuse der Baureihe 300

	Einsätze		Seite		Seite		Seite	
	UC300	EX300	UC300	EX300	UC300+H	EX300+H	UC300+H	EX300+H
Steh-lager-gehäuse	Seite	 165	Seite	 166	Seite	 167	Seite	
	Gehäuse							
Flanschlager-gehäuse	P	 UCP	44	EXP	44	UKP+H	44	
	F	 UCF	72	EXF	72	UKF+H	72	
	FS	 UCFS	90	EXFS	90	UKFS+H	90	
	FL	 UCFL	100	EXFL	100	UKFL+H	100	
Spannplatten- und Hülsen-lagergehäuse	T	 UCT	120	EXT	120	UKFL+H	120	
	C	 UCC	138	EXC	138	UKC+H	138	

Stahlblech-Gehäuse der Baureihe 200

	Einsätze		Seite		Seite	
	US200	ES200	US200	ES200	US200	ES200
Steh-lager-gehäuse	Seite	 161	Seite	 162	Seite	
	Gehäuse					
Flanschlagergehäuse	PP	 USPP	150	ESPP	150	
	PF	 USPF	152	ESPF	152	
	PFL	 USPFL	154	ESPFL	154	
	PFT	 USPFT	156	ESPFT	156	
	PFE	 USPFE	158	ESPFE	158	

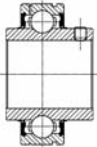
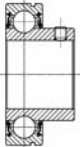
Einsätze mit zylindrischem Außenring

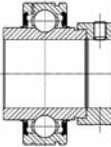
Einsätze	CUC200	Seite	CUS200	Seite	CES200	Seite	CEX200	Seite
		168		169		170		171



Bezeichnungsschema

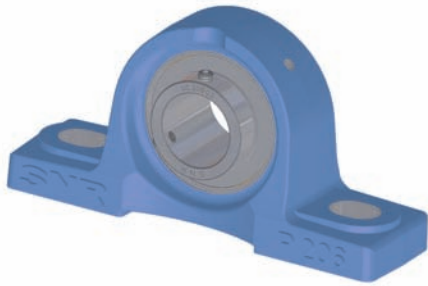

Gehäuselagereinheiten

SNR-Gehäuselagereinheiten werden durch den Einsatz, Gehäusotyp und Wellendurchmesser definiert.

Bei SNR-Gehäuselager-Bezeichnungen wird zuerst der Einsatz beschrieben (z.B. Bauform „UC“).

UCP205

Als Nächstes folgt die Angabe des Gehäusetyps (z.B. „P“).

UCP205

Die erste Ziffer beschreibt die Durchmesserreihe (200 oder 300)

UCP205

Zum Schluss gibt die Kennziffer die notwendigen Informationen über den Wellendurchmesser (z.B. „205“ = 25 mm Wellendurchmesser).

UCP205

Weitere technische Eigenschaften werden durch Nachsetzzeichen beschrieben (siehe Seite 7).

Detaillierte Informationen zu den unterschiedlichen Gehäusebauformen finden Sie auf den Seiten 8 bis 9 dieses Kataloges.

Bestellbeispiel

Stehlagerlagergehäuse

UCP205CC (eine geschlossene und eine offene Schutzkappe)

UCP205CO (zwei offene Schutzkappen)

Flanschlagergehäuse

UCF205CC (eine geschlossene Schutzkappe)

UCF205CO (eine offenen Schutzkappe)



Einsätze

Die verschiedenen SNR-Gehäuselager-Einsätze werden durch die vorangestellten Buchstaben (z.B. „UC“) bestimmt

UC205

Detaillierte Informationen zu den unterschiedlichen Bauformen finden Sie auf den Seiten 16 und 17.

Die erste Ziffer beschreibt die Durchmesserreihe (200 oder 300)

UC205

Mit den beiden letzten Ziffern wird die Bohrung definiert. Die Ziffern ergeben 1/5 des Bohrungsdurchmessers (z.B. „04“ = 20 mm, „06“ = 30 mm). Eine Ausnahme bilden lediglich die kleineren Bohrungsdurchmesser von 12 bis 17 mm.

UC205

Bohrungs-Kennziffer	Wellendurchmesser
01	12 mm
02	15 mm
03	17 mm
04	20 mm
05	25 mm
06	30 mm
:	:
10	50 mm

inch Maßreihe

Die beiden letzten Ziffern sind eine Kennzahl für den Bohrungsdurchmesser in inch. Genaue Angaben der Durchmesser finden Sie in den Maßtabellen der Einsätze ab Seite 160.



















UC205-16

Vor- und Nachsetzzeichen

Vor- bzw. Nachsetzzeichen	Beschreibung
C3	Radiale Lagerluft größer als normal
C4	Radiale Lagerluft größer als C3
CC	Geschlossene Schutzkappe aus rostfreiem Stahl
CO	Offene Schutzkappe aus rostfreiem Stahl mit Zweilippendichtung
G2	SNR-Nachschmiersystem
H	Spannhülse für Einsätze mit konischer Bohrung
L3	Dreilippendichtung
M	Metrische Gewindebohrung
N	Nut im Gehäuse zur Befestigung der Schutzkappen
PN	Vernickelte Gehäuseoberfläche
PZ	Verzinkte Gehäuseoberfläche
S	Werkstoff rostfreier Stahl (Vorsetzzeichen)
T04	Einsatz für Betriebstemperaturen bis -40 °C
T20	Einsatz für Betriebstemperaturen bis $+200\text{ °C}$



Gehäusebauformen

Bau- formen		Beschreibung	Maßlisten ab Seite
C200		Zylindrisches Hülsenlagergehäuse aus Grauguss, nachschmierbar	138
C300		Zylindrisches Hülsenlagergehäuse aus Grauguss, nachschmierbar	138
EHE200		Hängelagergehäuse aus Grauguss mit metrischem Befestigungsgewinde, nachschmierbar	146
F200		Quadratisches Flanschlagergehäuse aus Grauguss mit 4 Befestigungsbohrungen, nachschmierbar	72
F300		Quadratisches Flanschlagergehäuse aus Grauguss mit 4 Befestigungsbohrungen, nachschmierbar	72
FA200		Ovales Flanschlagergehäuse aus Grauguss mit 1 Befestigungsbohrung und 1 Langloch, nachschmierbar	116
FAE200		Ovales Flanschlagergehäuse aus Grauguss mit 1 Befestigungsbohrung und 1 Langloch, nachschmierbar	114
FC200		Rundes Flanschlagergehäuse aus Grauguss mit Zentrieransatz und 4 Befestigungsbohrungen, nachschmierbar	84
FCE200		Rundes Flanschlagergehäuse aus Grauguss mit Zentrieransatz und 4 Befestigungsbohrungen, nachschmierbar	80
FD200		Flaches, ovales Flanschlagergehäuse aus Grauguss mit 2 Befestigungs- bzw. Gewindebohrungen, nachschmierbar	112
FE200		Quadratisches Flanschlagergehäuse aus Grauguss mit 4 Befestigungsbohrungen, nachschmierbar	68
FEE200		Rundes Flanschlagergehäuse aus Grauguss mit Zentrieransatz und 4 Befestigungsbohrungen, nachschmierbar	88
FL200		Ovales Flanschlagergehäuse aus Grauguss mit 2 Befestigungsbohrungen, nachschmierbar	100
FL300		Ovales Flanschlagergehäuse aus Grauguss mit 2 Befestigungsbohrungen, nachschmierbar	100
FLE200		Ovales Flanschlagergehäuse aus Grauguss mit 2 Befestigungsbohrungen, nachschmierbar	96
FLZ200		Ovales Flanschlagergehäuse aus Grauguss mit Zentrieransatz und 2 Befestigungsbohrungen, nachschmierbar	108
FS300		Quadratisches Flanschlagergehäuse aus Grauguss mit Zentrieransatz und 4 Befestigungsbohrungen, nachschmierbar	90
FTE200		Dreieckiges Flanschlagergehäuse aus Grauguss mit 3 Befestigungsbohrungen, nachschmierbar	94

Gehäusebauformen

Bau- formen	Beschreibung	Maßlisten ab Seite
P200	 Stehlagergehäuse aus Grauguss mit 2 Langlöchern zur Befestigung, nachschmierbar	44
P300	 Stehlagergehäuse aus Grauguss mit 2 Langlöchern zur Befestigung, nachschmierbar	44
PA200	 Stehlagergehäuse aus Grauguss mit 2 Gewindebohrungen zur Befestigung von unten, nachschmierbar	64
PAE200	 Stehlagergehäuse aus Grauguss mit 2 Gewindebohrungen zur Befestigung von unten, nachschmierbar	56
PE200	 Stehlagergehäuse aus Grauguss mit 2 Langlöchern zur Befestigung, nachschmierbar	36
PF200	 Rundes Flanschlagergehäuse aus Stahlblech mit 3 oder 4 Befestigungsbohrungen, nicht nachschmierbar	152
PFE200	 Viereckiges Spannlagergehäuse aus Stahlblech mit 4 Langlöchern zur Befestigung, nicht nachschmierbar	158
PFL200	 Ovale Flanschlagergehäuse aus Stahlblech mit 2 Befestigungsbohrungen, nicht nachschmierbar	154
PFT200	 Dreieckiges Flanschlagergehäuse aus Stahlblech mit 3 Befestigungsbohrungen, nicht nachschmierbar	156
PG200	 Stehlagergehäuse aus Grauguss mit 2 Gewindebohrungen zur Befestigung von unten, nachschmierbar	60
PH200	 Stehlagergehäuse aus Grauguss für erhöhte Wellenmitte mit 2 Langlöchern zur Befestigung, nachschmierbar	52
PLE200	 Stehlagergehäuse aus Grauguss mit 2 Langlöchern zur Befestigung, nachschmierbar	40
PP200	 Stehlagergehäuse aus Stahlblech mit 2 Befestigungsbohrungen, nicht nachschmierbar	150
SP200	 Spannlagergehäuse aus Grauguss, nachschmierbar	132
SPR	 Rahmen für Spannlagergehäuse aus Stahl	136
T200	 Spannlagergehäuse aus Grauguss mit Aufnahme für Gewindestange und Mutter, beidseitige Führungsnuten, nachschmierbar	120
T300	 Spannlagergehäuse aus Grauguss mit Aufnahme für Gewindestange und Mutter, beidseitige Führungsnuten, nachschmierbar	120
WB200	 Spannrahmen für Spannlagergehäuse T200 aus Stahl	128



Gehäuselager aus Grauguss

Vorteile SNR-Gehäuselager aus Grauguss



- Korrosionsschutz durch passivierte und lackierte Oberflächen
- Nachschmierbar
- Ausgleich von Fluchtungsfehlern
- Zusätzliche Baureihe 300 für hohe Belastungen
- Umfangreiches Standard-Lieferprogramm

SNR-Gehäuselager gibt es als Steh-, Flansch-, Hänge-, Hülsen- oder Spannlager. Diese bieten unterschiedliche Möglichkeiten zur Befestigung, wie z.B. Durchgangs- oder Gewindebohrungen. Alle SNR-Gehäuselager aus Grauguss haben Gewindebohrungen zur Aufnahme der Schmiernippel.

Ausführung

Lieferzustand

SNR-Gehäuselager aus Grauguss werden einbaufertig geliefert. Der montierte Einsatz ist lebensdauergeschmiert (weitere Informationen finden Sie im Abschnitt „Schmierung und Wartung“ ab Seite 34). Die Gewindebohrung zur Aufnahme der Schmiernippel ist mit einem Stopfen aus Kunststoff verschlossen. Der passende Schmiernippel liegt der Einheit lose bei.

Fluchtungsfehler

Durch den sphärisch ausgeführten Lagersitz sind SNR-Gehäuselager aus Grauguss in der Lage, Fluchtungsfehler auszugleichen. Der eingebaute Einsatz ist in alle Richtungen winkelbeweglich. Fluchtungsfehler der Welle werden somit bis zu einem bestimmten Grad ausgeglichen. Diese Selbsteinstellung sollte aber nur einmal erforderlich sein und darf im Betrieb nicht ständig erfolgen.

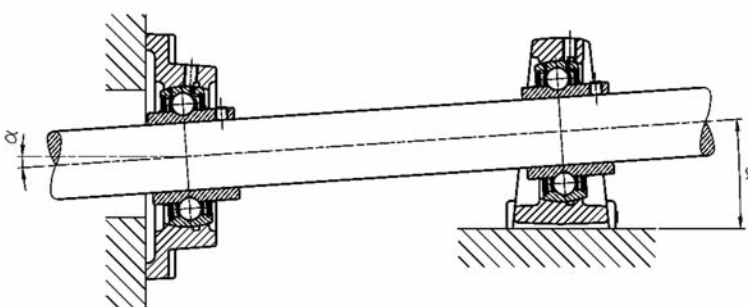

nachschmierbare Gehäuselager

$$\alpha = \pm 2^\circ$$

nicht nachschmierbare Gehäuselager

$$\alpha = \pm 5^\circ$$

Gehäuselager mit Schutzkappen

$$\alpha = \pm 1^\circ$$

Werkstoffe/Oberflächen

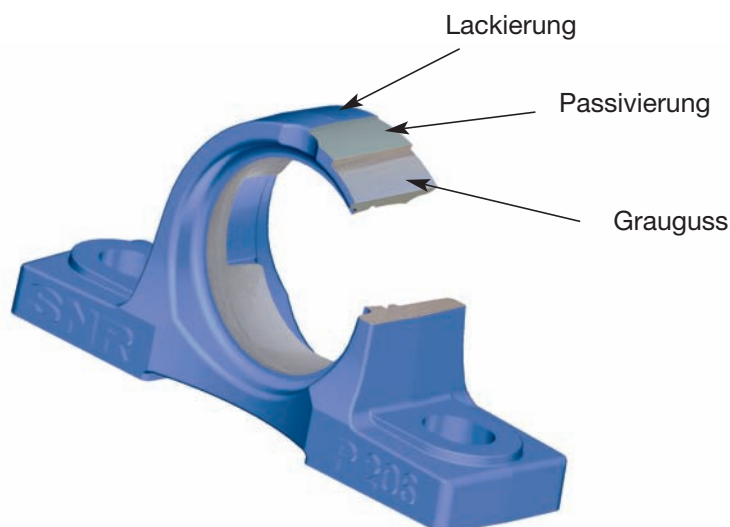

Werkstoff

SNR-Gussgehäuse bestehen je nach Type aus Qualitäts-Grauguss GG20 oder GG25.

Oberflächen

SNR-Gussgehäuse werden passiviert und anschließend im Farbton RAL 5010 lackiert.

Eine Lackierung in anderen Farben ist auf Wunsch möglich. Es besteht ebenfalls die Möglichkeit, Gehäuse von SNR verzinkt oder vernickelt zu beziehen.

Wünschen Sie Gehäuse in Sonderbauformen?

Erfordert Ihr Anwendungsfall andere Werkstoffe wie zum Beispiel Sphäroguss oder Stahlguss? Soll Ihr Gehäuse verzinkt oder vernickelt werden oder benötigen Sie Ihr Gehäuse in einer anderen Farbe?

Fragen Sie uns, wir verfügen über große Erfahrungen in der Realisierung von Sonderlösungen. Eine flexible Fertigung ermöglicht auch die Herstellung kleinerer Stückzahlen.

Unsere kurzen Lieferzeiten werden Sie überzeugen.

SNR-Gehäuselager – mehr als nur Standard!



Gehäuselager aus Grauguss

Belastbarkeit

SNR-Gehäuse erlauben es, die Tragzahlen der Lagereinsätze voll auszunutzen. Die angegebene radial dynamische Tragzahl der Lagereinsätze kann als maximale radiale Tragkraft der Einheit angenommen werden.

Bei Verwendung von Gehäusen der Baureihe T200 und T300 ist die radiale dynamische Tragzahl mit einem Faktor von 0,3 zu multiplizieren.

Die höchstzulässige axiale Belastbarkeit der Einsätze beträgt $0,5 \times C_{0r}$ (radiale statische Tragzahl).

Für unterschiedliche Beanspruchungsarten müssen folgende Sicherheitsfaktoren berücksichtigt werden:

Art der Beanspruchung	Sicherheitsfaktor
Konstante Belastung	1
Schwellende Belastung	1 – 1,5
Mäßige Stoßbelastung	2
Hohe Stoßbelastung	> 3

Radiale dynamische Tragzahlen (C_r) für Einsätze der Baureihen UC200 / UC300 / US200 / ES200 EX200 / EX300 / UK200 / UK300

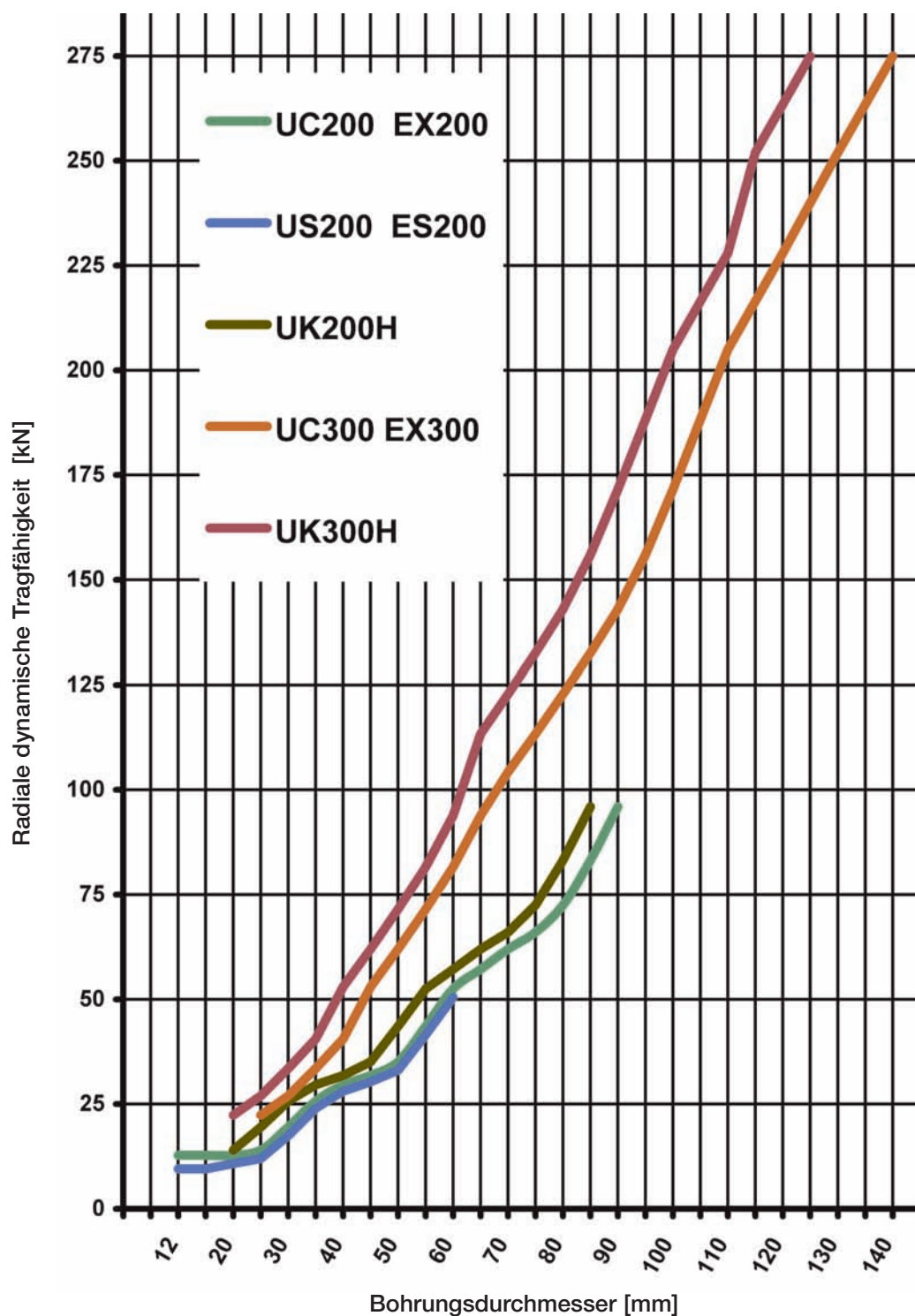



Gehäuselager aus Stahlblech

Ausführung



SNR-Gehäuselager aus Stahlblech gibt es als Steh-, Flansch- oder Spannlager. Die Gehäuse sind mit Durchgangsbohrungen zur Montage versehen. Gehäuselager aus Stahlblech sind nicht nachschmierbar.

Lieferzustand

SNR-Gehäuselager aus Stahlblech werden einbaufertig geliefert. Die Einsätze sind lebensdauergeschmiert. Sie sind den Gehäusen beigelegt.

Fluchtungsfehler

Durch den sphärisch ausgeführten Lagersitz sind SNR-Gehäuselager aus Stahlblech in der Lage, Fluchtungsfehler auszugleichen. Die eingebauten Einsätze sind in alle Richtungen winkelbeweglich. Fluchtungsfehler der Welle werden bis zu 6 Grad ausgeglichen.

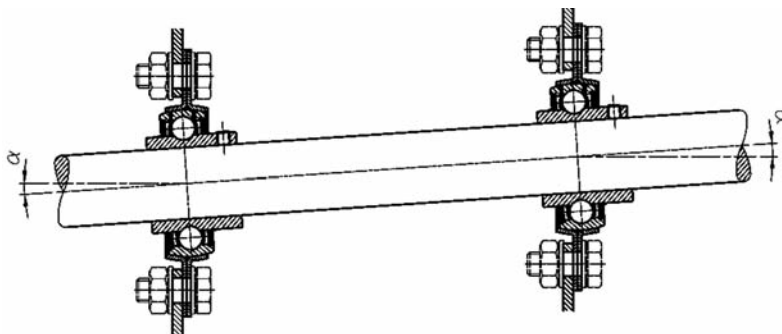

Gehäuselager aus Stahlblech
 $\alpha = \pm 5^\circ$

Werkstoffe/Oberflächen

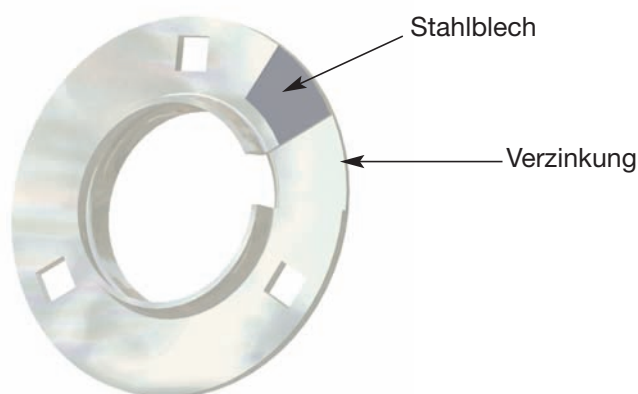

Werkstoff

SNR-Gehäuse aus Stahlblech bestehen aus Kaltband Stahlblech.

Oberflächen

SNR-Gehäuse aus Stahlblech sind verzinkt.

Belastbarkeit

Maximale Belastbarkeit der Gehäuse in radialer Richtung:

Flanschlager: $C_r \times 0,25$
Stehlager: $C_r \times 0,10$

Maximale Belastbarkeit der Gehäuse in axialer Richtung:

Flanschlager: $C_r \times 0,10$
Stehlager: $C_r \times 0,10$

C_r = radiale dynamische Tragzahl des verwendeten Einsatzes



Ausführungen

Gehäuselager-Einsätze entsprechen in ihrem inneren Aufbau im Wesentlichen den Standard-Rillenkugellagern der Reihen 6200 und 6300. Sie haben jedoch z.B. verbreiterte Innenringe zur leichteren Befestigung auf Wellen oder konische Bohrungen zur Montage mit Spannhülsen.

Alle Lagereinsätze sind beidseitig abgedichtet und sind sowohl mit zylindrischen als auch mit balligen Außenringen erhältlich.

	<p>Baureihe UC200/UC300 (sphärischer Außenring)</p> <ul style="list-style-type: none"> • nachschmierbar • beidseitig verlängerter Innenring • Befestigung auf der Welle mittels Gewindestifte • Ausführung als Loslager möglich • Dichtungen beidseitig mit zusätzlichen Schleuderscheiben • auch mit 3-fach-Dichtung lieferbar <p>Baureihe CUC200 (zylindrischer Außenring)</p> <ul style="list-style-type: none"> • Nut im Außenring zur Befestigung im Gehäuse mittels Sicherungsring • Nut im Außenring mit Schmierbohrungen • Ausführung sonst wie UC200 	
	<p>Baureihe US200 (sphärischer Außenring)</p> <ul style="list-style-type: none"> • nachschmierbar • einseitig verlängerter Innenring • Befestigung auf der Welle mittels Gewindestifte • Ausführung als Loslager möglich • Dichtungen beidseitig <p>Baureihe CUS200 (zylindrischer Außenring)</p> <ul style="list-style-type: none"> • nicht nachschmierbar • Nut im Außenring zur Befestigung im Gehäuse mittels Sicherungsring • Ausführung sonst wie US200 	
	<p>Baureihe ES200 (sphärischer Außenring)</p> <ul style="list-style-type: none"> • nachschmierbar • einseitig verlängerter Innenring • Befestigung auf der Welle mittels Excenterring • Dichtungen beidseitig <p>Baureihe CES200 (zylindrischer Außenring)</p> <ul style="list-style-type: none"> • nicht nachschmierbar • Nut im Außenring zur Befestigung im Gehäuse mittels Sicherungsring • Ausführung sonst wie ES200 	

Ausführungen

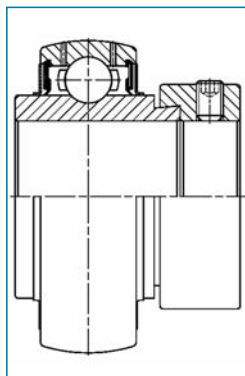

Baureihe EX200/EX300 (sphärischer Außenring)

- nachschmierbar
- beidseitig verlängerter Innenring
- Befestigung auf der Welle mittels Excenterring
- Dichtungen beidseitig mit zusätzlichen Schleuderscheiben
- auch mit 3-fach-Dichtung lieferbar

Baureihe CEX200 (zylindrischer Außenring)

- Nut im Außenring mit Schmierbohrungen
- Ausführung sonst wie EX200

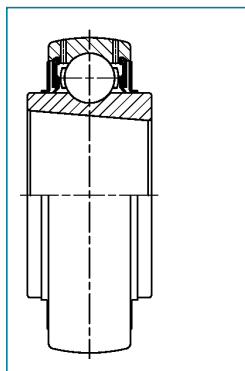
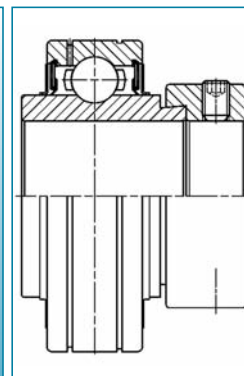

Baureihe UK200/UK300 (sphärischer Außenring)

- nachschmierbar
- Innenring mit kegeliger Bohrung zur Aufnahme der Spannhülse
- Befestigung auf der Welle mittels Spannhülse
- Dichtungen beidseitig mit zusätzlichen Schleuderscheiben
- auch mit 3-fach-Dichtung lieferbar

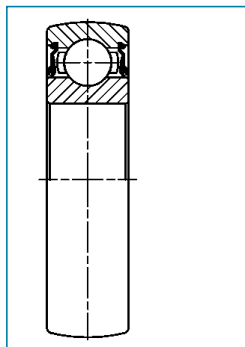

Baureihe 6200SEE (sphärischer Außenring)

- nicht nachschmierbar
- Abmessungen und Toleranzen wie Rillenkugellager der Baureihe 62
- Befestigung auf der Welle mittels Passung
- Dichtungen beidseitig

Lieferzustand

SNR-Gehäuselager-Einsätze werden einbaufertig ausgeliefert. Die Einsätze sind bereits mit einem geeigneten Wälzlagerfett lebensdauergeschmiert; unter normalen Betriebsbedingungen ist ein Nachschmieren der Wälzlager nicht notwendig.

Die notwendigen Bauteile zur Befestigung der Einsätze auf der Welle sind im Lieferumfang enthalten.

SNR-Gehäuselager-Einsätze sind entweder in das entsprechende Gehäuse eingebaut oder werden separat als Einzellager geliefert.



Werkstoffe

Innen- und Außenringe sowie die Kugeln der SNR-Gehäuselager-Einsätze bestehen aus gehärtetem Wälzlagerstahl 100 Cr6.

Einsätze werden standardmäßig mit 2-teiligen genieteten Käfigen aus Stahlblech geliefert.

Dichtungen bestehen aus Nitril-Kautschuk und verzinktem Stahlblech.

Befestigung auf der Welle

Ein Vorteil der SNR-Gehäuselager sind die geringen Anforderungen, die diese Art der Lagerung an die Welle stellt. Sie muß weder gehärtet noch geschliffen sein, auch die Oberflächenqualität stellt geringe Ansprüche. Wir empfehlen Wellenwerkstoffe mit einer Zugfestigkeit von mindestens 500 N/mm^2 . Die maximal zulässigen Drehzahlen sind außer von der Geometrie des Lagers auch von der Toleranz des Wellendurchmessers abhängig, wie nachfolgendem Diagramm zu entnehmen ist.

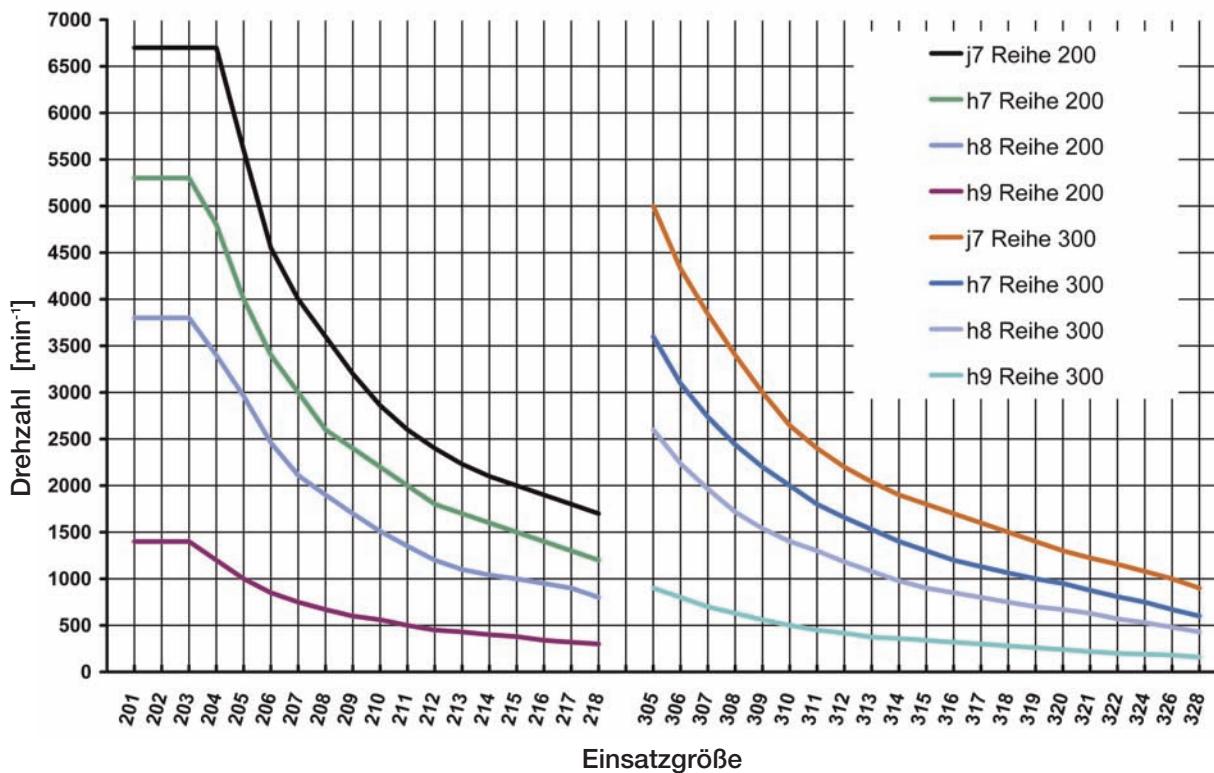

Für die meisten Anwendungsfälle bieten Gewindestifte eine ausreichend sichere Befestigung der Innenringe auf der Welle. Bei Excenterringbefestigung empfiehlt es sich, für die Lagersitze nach **h6** bis **h9** gefertigte Wellen zu verwenden. Werden kegelige Spannhülsen verwendet, ist die Wellentoleranz **h9** bis **h11** ausreichend. Liegen schwierige Betriebsverhältnisse vor, z. B. Erschütterungen oder Stöße, ist eine leichte Presspassung zu bevorzugen.

Möglichkeiten der Wellenbefestigung

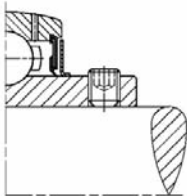
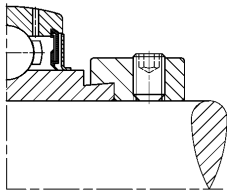
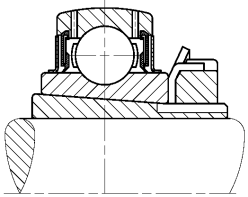
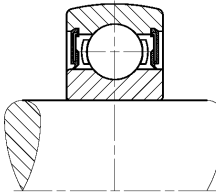
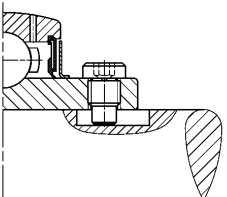
Befestigung	Merkmale	Anwendung	
Gewindestift mit Innensechskant	<ul style="list-style-type: none"> • 2 um 120 ° versetzte Gewindestifte mit Innensechskant und gerändelter Ringschneide 	<ul style="list-style-type: none"> • normale Belastungen • geringe bis mittlere Drehzahlen • leicht demontierbar 	
Excenterring	<ul style="list-style-type: none"> • Befestigung mittels Excenterring und Innensechskantschraube 	<ul style="list-style-type: none"> • normale Belastungen mit gleichbleibender Drehrichtung • nicht für Reversierbetrieb geeignet • geringe bis mittlere Drehzahlen 	
Spannhülse	<ul style="list-style-type: none"> • kegelige Spannhülse mit Sicherungsblech und Nutmutter • konzentrische Wellenbefestigung 	<ul style="list-style-type: none"> • höhere Drehzahlen • für Reversierbetrieb geeignet • hohe Laufruhe 	
Passung	<ul style="list-style-type: none"> • Befestigung mittels Wellenpassung 	<ul style="list-style-type: none"> • mittlere bis hohe Drehzahlen • normale bis hohe Belastungen • geringer Bauraum 	
Loslagerschraube	<ul style="list-style-type: none"> • Stiftschraube in Wellenut axial verschiebbar 	<ul style="list-style-type: none"> • geringe Drehzahlen und Belastungen • große Längenausdehnungen (z.B. durch Temperaturschwankungen) 	

Genauere Angaben zu den einzelnen Befestigungsmöglichkeiten befinden sich auf den folgenden Seiten.



Befestigungsschrauben der Lagereinsätze

metrisch

Befestigungsschraube	Lagereinsatz						max. Anzugsmoment [Nm]	Innen-sechskant SW
	UC CUC	US CUS	ES CES	EX CEX				
M5 x 0,8			201-203				3,5	2,5
M6 x 1	201-206	305-306	204-207	201-206	201-206		5,5	3,0
M8 x 1	207-209	307	208-210	207-210	207-210	305-307	11,5	4,0
M10 x 1,25	210-212	308-309	211-212	211-212	211-215	308-312	22,0	5,0
M12 x 1,25	213-218	310-314			216-218	313-314	33,0	6,0
M14 x 1,5		315-316					42,0	7,0
M16 x 1,5		317-319				315-317	64,0	8,0
M18 x 1,5		320-324					75,0	9,0
M20 x 1,5		326-328				318-320	120,0	10,0

inch

Befestigungsschraube	Lagereinsatz						max. Anzugsmoment [Nm]	Innen-sechskant SW
	UC CUC	US CUS	ES CES	EX CEX				
10# - 32 UNF			201-08 203-11				3,2	3/32
1/4 - 28 UNF	201-08 206-20	305-14 306-19	204-12 206-20	201-08 205-16	201-08 205-16		3,7	1/8
5/16 - 24 UNF	207-22 209-28	307-20 307-23	207-22 211-35	206-18 210-31	206-18 210-31	305-14 307-23	8,0	5/32
3/8 - 24 UNF	210-30 213-40	308-24 309-28	212-36 212-39	211-32 212-39	211-32 215-48	308-24 312-39	16,8	3/16
7/16 - 20 UNF	214-44 217-52	310-30 314-44			217-52 218-56	313-40 314-44	27,1	7/32
1/2 - 20 UNF		315-47 315-48					33,9	1/4
5/8 - 18 UNF		317-52 320-64				315-48 317-52	54,5	5/16
3/4 - 16 UNF						318-56 320-64	65,2	3/8

Abmessungen Loslagerschrauben

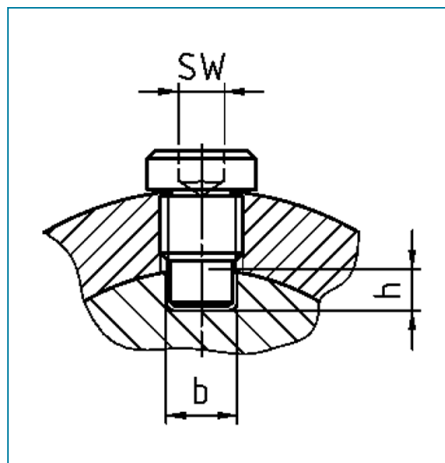

Abmessungen der Wellennut

Bezeichnung Loslager- schraube	Gewinde	SW
SH 06 x 075	M6x1	3
SH 06 x 090	M6x1	3
SH 06 x 100	M6x1	3
SH 06 x 110	M6x1	3
SH 08 x 105	M8x1	4
SH 08 x 115	M8x1	4
SH 10 x 110	M10x1,25	5
SH 10 x 125	M10x1,25	5
SH 10 x 135	M10x1,25	5
SH 12 x 145	M12x1,25	6
SH 12 x 155	M12x1,25	6
SH 12 x 175	M12x1,25	6
SH 14 x 200	M14x1,5	6
SH 16 x 215	M16x1,5	8
SH 16 x 235	M16x1,5	8
SH 18 x 250	M18x1,5	8
SH 18 x 300	M18x1,5	8
SH 20 x 330	M20x1,5	10

Anschlussmaße für Loslagerschrauben Reihe 200

Bezeichnung Lagereinsatz	Schraube	Anschlussmaße [mm]	
		h	b
UC 201	SH 06 x 110	3,0	4
UC 202	SH 06 x 100	3,5	4
UC 203	SH 06 x 090	3,5	4
UC 204	SH 06 x 075	3,5	4
UC 205	SH 06 x 075	3,5	4
UC 206	SH 06 x 090	4,5	4
UC 207	SH 08 x 105	4,5	6
UC 208	SH 08 x 105	4,5	6
UC 209	SH 08 x 105	5,0	6
UC 210	SH 10 x 110	5,5	7
UC 211	SH 10 x 125	6,0	7
UC 212	SH 10 x 135	6,5	7
UC 213	SH 12 x 125	5,5	7
UC 214	SH 12 x 145	6,5	9
UC 215	SH 12 x 145	6,5	9
UC 216	SH 12 x 155	7,5	9
UC 217	SH 12 x 175	8,0	9
UC 218	SH 12 x 175	7,5	9

Anschlussmaße für Loslagerschrauben Reihe 300

Bezeichnung Lagereinsatz	Schraube	Anschlussmaße [mm]	
		h	b
UC 305	SH 06 x 090	4,0	4
UC 306	SH 06 x 110	4,5	4
UC 307	SH 08 x 105	4,0	6
UC 308	SH 10 x 125	4,5	7
UC 309	SH 10 x 135	5,5	7
UC 310	SH 12 x 145	5,5	9
UC 311	SH 12 x 155	6,0	9
UC 312	SH 12 x 155	5,5	9
UC 313	SH 12 x 175	6,5	9
UC 314	SH 12 x 175	6,0	9
UC 315	SH 14 x 200	7,5	10
UC 316	SH 14 x 200	6,5	10
UC 317	SH 16 x 215	7,5	12
UC 318	SH 16 x 235	9,0	12
UC 319	SH 16 x 235	8,0	12
UC 320	SH 18 x 250	8,0	13
UC 321	SH 18 x 250	7,5	13
UC 322	SH 18 x 300	11,0	13
UC 324	SH 18 x 300	9,0	13
UC 326	SH 20 x 330	10,0	15
UC 328	SH 20 x 330	8,5	15



SNR Gehäuselager

Anzugsmomente der Nutmuttern bei Spannhülsenbefestigung

Lagereinsatz		max. Anzugs- moment [Nm]	Hakenschlüssel DIN 1810 A Größe
UK 205	UK 305	20	38-45
UK 206	UK 306	30	45-50
UK 207	UK 307	40	52-55
UK 208	UK 308	50	58-62
UK 209	UK 309	60	65-70
UK 210	UK 310	70	65-70
UK 211	UK 311	95	68-75
UK 212	UK 312	125	80-90
UK 213	UK 313	150	85-92
UK 215	UK 315	350	98-105
UK 216	UK 316	400	98-105
UK 217	UK 317	450	110-115
UK 218	UK 318	550	120-130
	UK 319	650	120-130
	UK 320	800	120-130
	UK 322	1050	135-145
	UK 324	1350	155-165
	UK 326	1650	155-165
	UK 328	1900	180-195

Die Bezeichnung der entsprechenden Spannhülsen ist in den Maßtabellen aufgeführt.

Abdichtungen

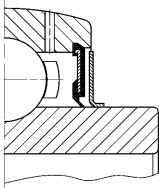
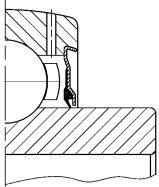
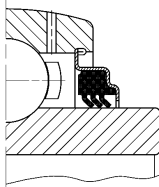
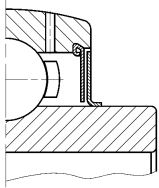
Beschreibung	Anwendungen	
<p>Dichtung mit Schleuderscheibe</p> <p>2-teiliges Dichtungssystem bestehend aus Stahlblechscheibe mit aufvulkanisierter einlippiger Nitrilkautschuk-Dichtung und zusätzlicher Schleuderscheibe aus Stahlblech</p>	<ul style="list-style-type: none"> • Zusätzlicher mechanischer Schutz der Dichtung vor Fremdkörpern • Mittlere bis hohe Drehzahlen 	
<p>Einlippendichtung</p> <p>Dichtung bestehend aus Stahlblech mit aufvulkanisierter Dichtlippe aus Nitril-Kautschuk</p>	<ul style="list-style-type: none"> • Normale Umgebungsbedingungen • Mittlere bis hohe Drehzahlen 	
<p>Dreilippendichtung</p> <p>1-teilige Dichtung bestehend aus Stahlblechscheibe mit aufvulkanisierter Dreilippendichtung</p>	<ul style="list-style-type: none"> • Umgebung mit starker Verschmutzung • Geringe bis mittlere Drehzahlen 	
<p>Hochtemperaturdichtung</p> <p>2-teilige nichtschleifende Abdichtung aus Stahlblech</p>	<ul style="list-style-type: none"> • Temperaturen bis +200 °C 	



Betriebstemperatur

Standard-Gehäuselager-Einsätze sind für alle Anwendungsfälle im Temperaturbereich von -20 °C bis +100 °C geeignet.

SNR-Hochtemperatur-Lagereinsätze wurden speziell für Anwendungsfälle entwickelt, in denen die Betriebstemperatur oberhalb des oben genannten Bereiches liegt. Sie haben wie die Standard-Einsätze einen Stahlblechkäfig. Sie sind jedoch mit einem Hochtemperaturfett ausgestattet und können bis +200 °C eingesetzt werden. Das Nachsetzzeichen für diese Einsätze lautet „T20“ und wird bei Bestellungen der Lagerbezeichnung hinzugefügt, z.B. „UCP206T20“.

Für Anwendungen unterhalb des normalen Temperaturbereiches (bis -40 °C) können wir Lagereinsätze mit der Bezeichnung „T04“ liefern. Auch sie haben einen Stahlblechkäfig, sind aber mit einem Tieftemperaturfett gefüllt. Bei Bestellungen wird die Bezeichnung ebenfalls angehängt, z.B. „UCP206T04“.

Nähere Angaben zu den verwendeten Schmierstoffen finden Sie im Abschnitt „Schmierung und Wartung“ ab Seite 34.

Lagerluft

Standard-Gehäuselager-Einsätze werden mit erhöhter Lagerluft der Gruppe C3 gefertigt.

Einsätze für Hoch- oder Tieftemperaturanwendungen haben C4-Lagerluft.

Die Werte der Lagerluft können Sie den folgenden Tabellen entnehmen:

Einsätze mit zylindrischer Bohrung

Bohrung Nennmaß [mm]		Radiale Lagerluft [µm]					
		normal		C3		C4	
über	bis	min.	max.	min.	max.	min.	max.
10	18	3	18	11	25	18	33
18	24	5	20	13	28	20	36
24	30	5	20	13	28	23	41
30	40	6	20	15	33	28	46
40	50	6	23	18	36	30	51
50	65	8	28	23	43	38	61
65	80	10	30	25	51	46	71
80	100	12	36	30	58	53	84
100	120	15	41	36	66	61	97
120	140	18	48	41	81	71	114

Einsätze mit kegeliger Bohrung

Bohrung Nennmaß [mm]		Radiale Lagerluft [µm]					
		normal		C3		C4	
über	bis	min.	max.	min.	max.	min.	max.
24	30	13	28	23	41	32	50
30	40	15	33	28	46	39	60
40	50	18	36	30	51	43	68
50	65	23	43	38	61	54	84
65	80	25	51	46	71	64	99
80	100	30	58	53	84	74	114
100	120	36	66	61	97	89	134
120	140	41	81	71	114	109	159

Axiale Belastbarkeit der Einsätze

Die axiale Belastbarkeit des Einsatzes hängt überwiegend von der Art seiner Befestigung auf der Welle ab. Die innere Konstruktion der Laufbahnen und Kugeln ist in den meisten Anwendungsfällen von geringerer Bedeutung. Ein weiterer Faktor ist die verwendete Wellentoleranz.

Um die größtmögliche axiale Belastbarkeit für die jeweilige Befestigungsart erreichen zu können, ist es notwendig, dass das Befestigungselement (z.B. Gewindestift, Spannhülse) mit dem vorgegebenen Anzugsmoment fixiert ist.

Bei starken Schwingungen oder Stoßbelastungen empfiehlt es sich, den Innenring gegen eine Wellenschulter zu setzen und evtl. mit Nutmutter und Sicherungsblech zu fixieren. In diesem Fall kann die axiale Tragfähigkeit des Einsatzes, wie bei Standard-Rillenkugellagern, voll ausgeschöpft werden. Diese kann bis zum 0,5-fachen der radialen statischen Tragzahl C_{0r} betragen. Ein solcher Anwendungsfall sollte jedoch eingehend unter Berücksichtigung der jeweiligen Lastbedingungen untersucht werden.

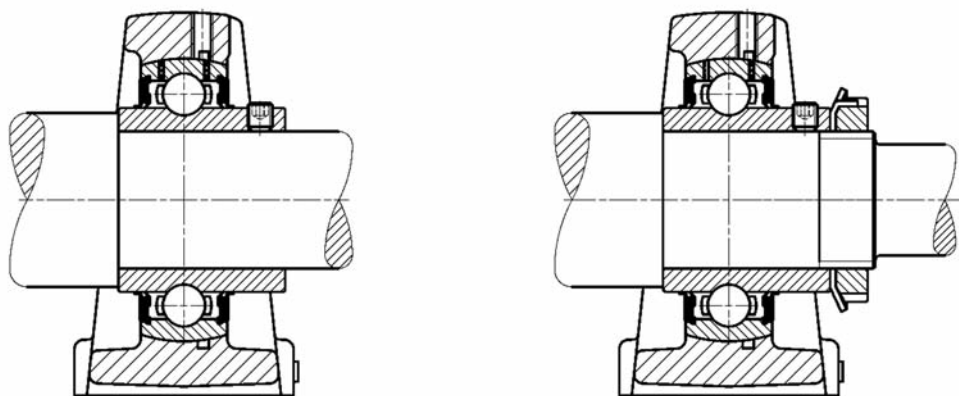

Tragfähigkeit und Drehzahlgrenzen

Tragfähigkeiten der Einsätze sind in den Maßtabellen ab Seite 160 angegeben. Die Auswirkung von Wellentoleranzen auf die Drehzahlgrenzen ist im Diagramm auf Seite 18 dargestellt.



Lebensdauerberechnung

Berechnung der Lebensdauer

Die Einsätze der SNR-Gehäuselager sind in ihrem inneren Aufbau dem der Rillenkugellager identisch. Sie sind aus dem gleichen Werkstoff gefertigt, besitzen die gleiche Präzision und unterliegen den gleich strengen Fertigungskontrollen.

Die Berechnung der Lebensdauer und der Tragzahlen beruht auf den Berechnungsmethoden gemäß ISO 281 und ISO 76.

Bestimmung der Lagergrößen

Vor der Berechnung der Lebensdauer des Gehäuselagers müssen die auftretenden Belastungen ermittelt werden. Die erforderliche Lagergröße hängt im Wesentlichen von der Belastung und von der Drehzahl ab. Tritt die Belastung vor allem bei rotierendem Lager auf, so spricht man von dynamischer Belastung. Wirkt die Belastung jedoch hauptsächlich im Stillstand, bei sehr niedrigen Drehzahlen oder bei geringen Schwenkbewegungen, so spricht man von statischer Belastung.

Dabei ist es unerheblich, wie die von außen angreifenden Kräfte auf das Lager wirken. Die Angaben dynamisch oder statisch beziehen sich nur auf den Betriebszustand des Lagers.

Dynamisch äquivalente Belastung

Wirken auf ein Lager gleichzeitig radiale und axiale Belastungen, so müssen diese wie folgt in eine für die Berechnung erforderliche äquivalente Belastung (P) umgerechnet werden:

$$P = X \cdot F_r + Y \cdot F_a \quad [kN]$$

P = dynamisch äquivalente Belastung [kN]

F_r = tatsächliche radiale Belastung [kN]

F_a = tatsächliche axiale Belastung [kN]

X = Radialfaktor

Y = Axialfaktor

$\frac{F_a}{C_{0r}}$	e	$\frac{F_a}{F_r} \leq e$		$\frac{F_a}{F_r} > e$	
		X	Y	X	Y
0,014	0,19				2,30
0,028	0,22				1,99
0,056	0,26				1,71
0,084	0,28				1,55
0,110	0,30	1	0	0,56	1,45
0,170	0,34				1,31
0,280	0,38				1,15
0,420	0,42				1,04
0,560	0,44				1,00

e = Grenzwert

C_{0r} = radiale statische Tragzahl
(siehe Maßtabellen der Gehäuselager)

Statisch äquivalente Belastung

Bei gleichzeitiger auftretender radialer und axialer statischer Belastung muss eine äquivalente Belastungsgröße (P_0) ermittelt werden:

$$P_0 = X_0 \cdot F_r + Y_0 \cdot F_a \quad [\text{kN}]$$

$$\text{aber: } P_0 = F_r, \quad \text{wenn } \frac{F_a}{F_r} \leq 0,8$$

P_0 = statisch äquivalente Belastung [kN]

X_0 = statischer Radialfaktor

Y_0 = statischer Axialfaktor

Für alle Einsätze gilt:

$$X_0 = 0,6$$

$$Y_0 = 0,5$$

Mit dem Verhältnis fs läßt sich ansatzweise überprüfen, ob eine ausreichende statische Dimensionierung des Einsatzes gewährleistet ist:

$$fs = \frac{C_{or}}{P_0}$$

Einige Richtwerte sind:

$fs = 0,7$ geringe Ansprüche an Laufruhe und Schwenkbewegung

$fs = 1,0$ zeitweise drehendes Lager, normale Ansprüche an die Laufruhe

$fs = 2,0$ hohe Ansprüche an die Laufruhe

Es ist zu beachten, dass dieses Verhältnis keine Sicherheit gegen Bruch o.ä., sondern eine Sicherheit gegen zu große örtliche Verformung im Wälzkontakt (Kugel/Laufbahn) darstellt.

Berechnung der Lebensdauer

Bei der Berechnung der Lebensdauer von Gehäuselagern gilt:

$$L_{10} = \left(\frac{C_r}{P} \right)^3 \quad [10^6 \text{ Umdrehungen}]$$

wird Angabe der Lebensdauer in Stunden gewünscht, so gilt:

$$L_{10h} = \left(\frac{C_r}{P} \right)^3 \cdot \frac{10^6}{60n} \quad [\text{h}]$$

n = Drehzahl [min⁻¹]



Berechnungsbeispiel

Lebensdauer eines Gehäuselagers UCP210 unter folgenden Bedingungen:

Radialbelastung:	F_r	= 2 kN
Axialbelastung:	F_a	= 1,7 kN
Normale Betriebsbedingungen Drehzahl:	n	= 1800 min ⁻¹
Gehäuselagerdaten UCP210:	C_r	= 35,1 kN
	C_{Or}	= 23,2 kN

Dynamische äquivalente Lagerbelastung:

$$P = X \cdot F_r + Y \cdot F_a \quad [\text{kN}]$$

$$\text{mit } \frac{F_a}{C_{Or}} = \frac{1,7 \text{ kN}}{23,2 \text{ kN}} = 0,073 \quad \text{und} \quad \frac{F_a}{F_r} = \frac{1,7 \text{ kN}}{2 \text{ kN}} = 0,85$$

aus Tabelle 1:

mit $F_a/C_{Or} = 0,073$ wird $e \approx 0,28$ ermittelt

mit $F_a/F_r = 0,85 > e = 0,28$

$$\rightarrow X=0,56 \quad Y=1,55$$

$$P = 0,56 \cdot 2 \text{ kN} + 1,55 \cdot 1,7 \text{ kN} = 3,76 \text{ kN}$$

$$L_{10h} = \left(\frac{C_r}{P} \right)^3 \cdot \left(\frac{10^6}{60n} \right) \quad [\text{h}]$$

folgt

$$L_{10h} = \left(\frac{35,1}{3,76} \right)^3 \cdot \left(\frac{10^6}{60 \times 1800} \right) = 7532 \text{ h}$$

Die theoretische Lebensdauer der Lagereinheit beträgt unter normalen Betriebsbedingungen 7532 Stunden.

Schutzkappen

Ausführungen

Um den Schutz vor rotierenden Wellen, eine erhöhte Dichtwirkung oder aber einen zusätzlichen mechanischen Schutz der Lagereinheiten in rauen Umgebungsbedingungen zu erzielen, besteht die Möglichkeit, einen Großteil der SNR-Gehäuselager mit Schutzkappen aus rostfreiem Stahl auszustatten. Diese sind geschlossen oder offen mit Zweilippendichtung für die Durchmesserreihen 201 bis 213 zu erhalten.



SCC - geschlossene Schutzkappe für Wellenenden

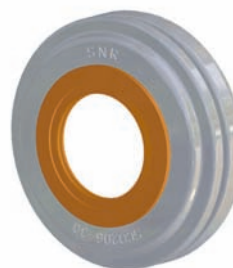

SCO - offene Schutzkappe mit Zweilippendichtung für durchgehende Wellen

Werkstoffe

Die Schutzkappen werden aus rostfreiem Stahl hergestellt. Die Zweilippendichtung besteht aus Silicon-Kautschuk.

Befestigung am Gehäuse

Zur Montage der Schutzkappe am Gehäuse sind keine besonderen Werkzeuge notwendig. Die Kappe wird in eine Ausdrehung am Gehäuse eingesetzt und ist durch den entstehenden Presssitz ausreichend fixiert.

Achtung: Gehäuse mit entsprechender Ausdrehung müssen gesondert bestellt werden. Nachsetzzeichen "N" z. B.: "UCP.206.N"

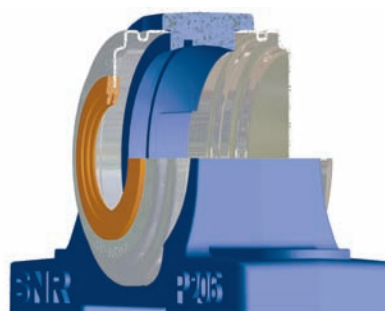



Schutzkappen

Montage der Schutzkappen

Montage der Schutzkappen



Demontage der Schutzkappen



Abdichtungen

Die Zweilippendichtung der SNR-Schutzkappe ist aus Silicon-Kautschuk hergestellt und ist für Betriebstemperaturen bis maximal +200°C geeignet.



Einheiten

Ausführungen

SNR-Gehäuselager-Einheiten werden montagefertig geliefert. Ist eine Nachschmierung notwendig, muß der beiliegende Schmiernippel montiert werden.

Gehäuse mit einer sphärischen Bohrung zur Aufnahme der Einsätze werden in zwei unterschiedlichen ISO-Toleranzen gefertigt. Bohrungsdurchmesser bis zu 180 mm werden in der Toleranzklasse **J7**, größere Bohrungsdurchmesser in der Toleranzklasse **H7**, gefertigt.

Die Fixierung der Einsätze über den Außenring im Gehäuse erfolgt bei Einsätzen mit einem Außendurchmesser bis zu 180 mm mittels Passungsitz. Einsätze mit einem Außendurchmesser größer als 180 mm werden über einer Verdrehsicherung im Gehäuse fixiert.

Montage

SNR Stehlager und Einsätze mit Gewindestiftbefestigung

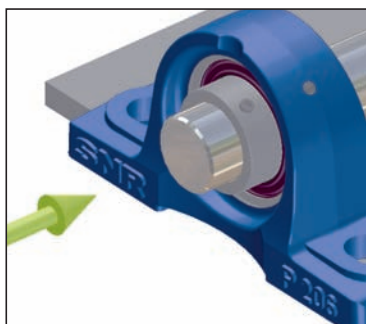

1. Gewindestifte lösen und Lagereinheit auf die Welle schieben.

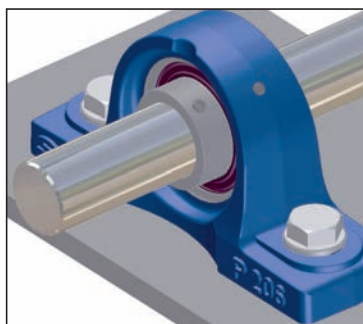

2. Das Gehäuse auf einer ebenen Fläche festschrauben. Gehäuse am anderen Wellenende in gleicher Weise montieren.

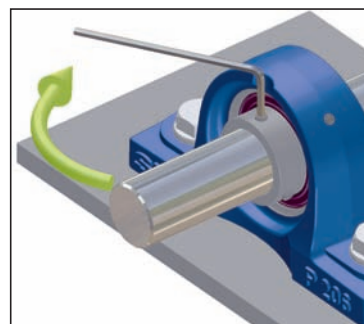

3. Gewindestifte gem. dem empfohlenen Anzugsmoment festschrauben.

SNR Stehlager und Einsätze mit Excenterringbefestigung

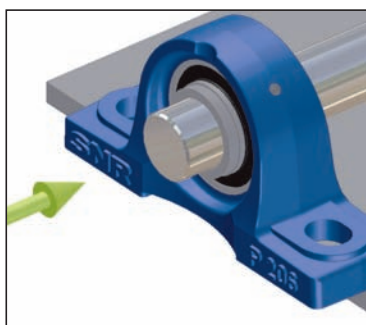

1. Einheit auf die Welle schieben. Excenterring nicht anziehen.

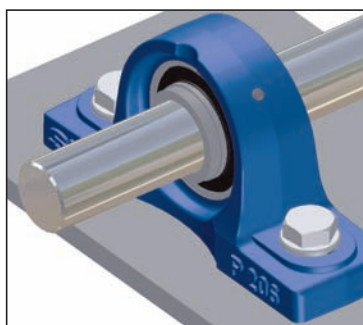

2. Schrauben leicht anziehen. Gehäuse und Lager am anderen Wellenende in gleicher Weise montieren. Schrauben fest anziehen.

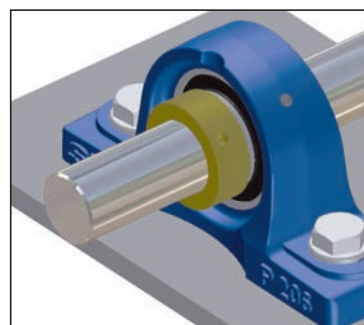

3. Excenterring vorzugsweise in Drehrichtung der Welle von Hand anziehen.



Montage

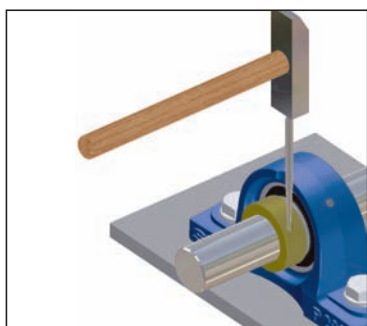

4. Excentrierung mit Dorn und Hammer festspannen.

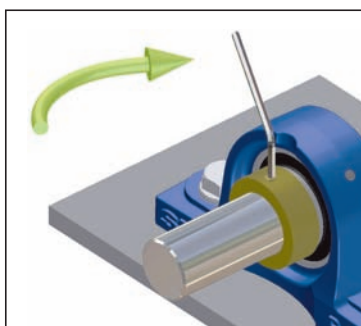

5. Gewindestift festziehen.

SNR Stehlager und Einsätze mit Spannhülsenbefestigung

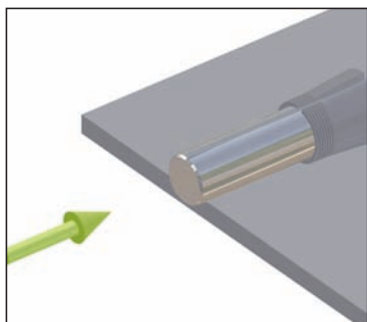

1. Spannhülse auf die Welle schieben.

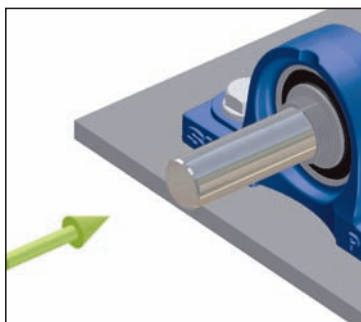

2. Einheit auf die Welle schieben.

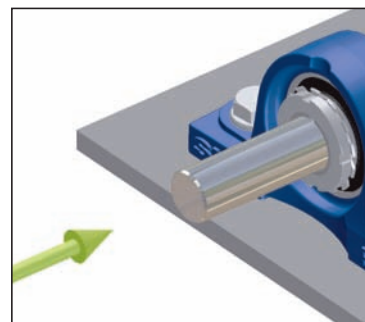

3. Einheit auf der Welle ausrichten, anschließend Gehäuse fest anschrauben.

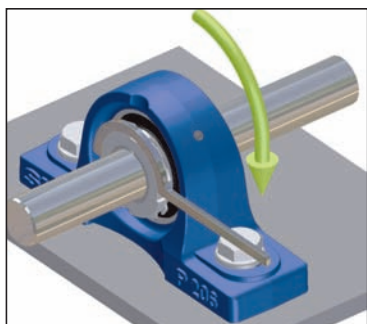

4. Sicherungsblech und Nutmutter montieren und anschließend mit empfohlenem Anzugsmoment anziehen.

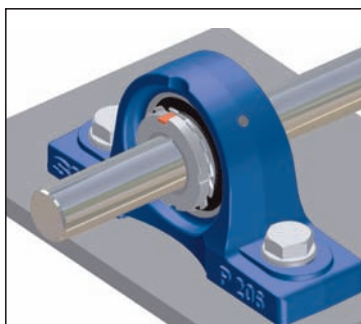

5. Spannhülse sichern (Lasche des Sicherungsbleches in eine Nut der Nutmutter umbiegen).

Zusätzliche Hinweise zur Montage

Um möglichen Beschädigungen der Lager durch unsachgemäße Montage vorzubeugen, müssen zuerst die Gehäuse auf ihrer jeweiligen Unterlage bzw. am Rahmen festgeschraubt werden, bevor die Innenringe der Einsätze in ihrer endgültigen Position auf der Welle befestigt werden. Andernfalls kann es zu unerwünschter axialer Verspannung und damit zu vorzeitigem Ausfall der Lager kommen.

Die Wellenenden sollten zur leichteren Montage mit einer Fase versehen werden.

Es ist sicherzustellen, dass die Gewindestifte der Lagereinsätze so weit zurückgeschraubt sind, dass sie nicht in die Innenringbohrung hineinragen. Andernfalls kann die Montage erschwert oder sogar die Welle beschädigt werden. Normalerweise werden die Lagerinnenringe mit einer engen Spielpassung auf die Welle geschoben. Erweist sich jedoch im Einzelfall eine Presspassung als unerlässlich, so sollten die Innenringe über ein passendes Rohrstück, vorzugsweise aus Messing oder Kunststoff, aufgetrieben werden.

Entsprechendes Montagewerkzeug für alle Lagereinsätze, aber auch für Standardwälzlager, finden Sie in unserem Lieferprogramm.

Direkte Hammerschläge auf die Einsätze oder die Gehäuse sind unbedingt zu vermeiden, da sie die Lager beschädigen können.

Nach beendeter Montage wird die Welle zunächst von Hand gedreht, um sicherzustellen, dass sie störungsfrei läuft.

Gussgehäuse sollten im Betrieb nach Möglichkeit auf Druck und nicht auf Zug beansprucht werden. Spannlagergehäuse sind so einzusetzen, dass die Spannschraube beim Einstellen gegen das Gehäuse drückt.

Graugussgehäuse sind für sehr hohe wechselnde Belastungen oder axial wirkende, schwellende Belastungen nicht geeignet. In solchen Anwendungen sollten Gehäuse aus Stahlguss oder Sphäroguss zum Einsatz kommen.

Einbaufälle mit großen Lagerabständen und Lagerungen, die aufgrund von erheblichen Temperaturschwankungen zusätzlichen Axialbelastungen ausgesetzt sind, erfordern konstruktive Sondermaßnahmen, wie zum Beispiel den Einbau einer Loslagerschraube.

Gehäusefixierung

Wird eine genaue Positionierung der Gehäuselager verlangt, können einige Gehäusetypen mittels vorhandener Zentrierung, Zylinder- oder Kegelstifte, fixiert werden.

Die Gehäusetypen mit den möglichen Positionen der Stiftbohrungen sind den Tabellen ab Seite 190 zu entnehmen.



Schmierung und Wartung

SNR-Gehäuselagereinsätze werden werkseitig mit der erforderlichen Menge an Schmierfett gefüllt. Bei der Montage ist deshalb eine zusätzliche Schmierung nicht erforderlich.

Eine Nachschmierung ist bei normalen Betriebsverhältnissen nicht notwendig.

Unter erschwerten Bedingungen, wie zum Beispiel Dauerbetrieb mit hohen Drehzahlen, hohen Temperaturen (über $+70^{\circ}\text{C}$ Betriebstemperatur), schwere Belastungen sowie sehr feuchte oder schmutzige Umgebung, ist eine regelmäßige Nachschmierung notwendig.

Die Nachschmiermengen sind von der Einsatzgröße abhängig. Die Nachschmierung sollte während des Betriebes erfolgen (drehender Einsatz unter Betriebstemperatur). Solange geeignetes Schmierfett in die Einheit pressen, bis sich an den Dichtungen ein frischer Fettkragen bildet.

Achtung: das alte Schmierfett muß ungehindert aus dem Einsatz austreten können.

Nachschmiersystem

Graugussgehäuse sind mit einer Schmiernut innerhalb der sphärischen Bohrung ausgestattet. Die Einsätze haben 4 Schmierbohrungen im Außenring, die versetzt angeordnet sind.

Durch die symmetrische Anordnung der Schmierbohrungen können SNR-Einsätze in fast allen Gehäusen mit Schmiernut eingebaut und nachgeschmiert werden.

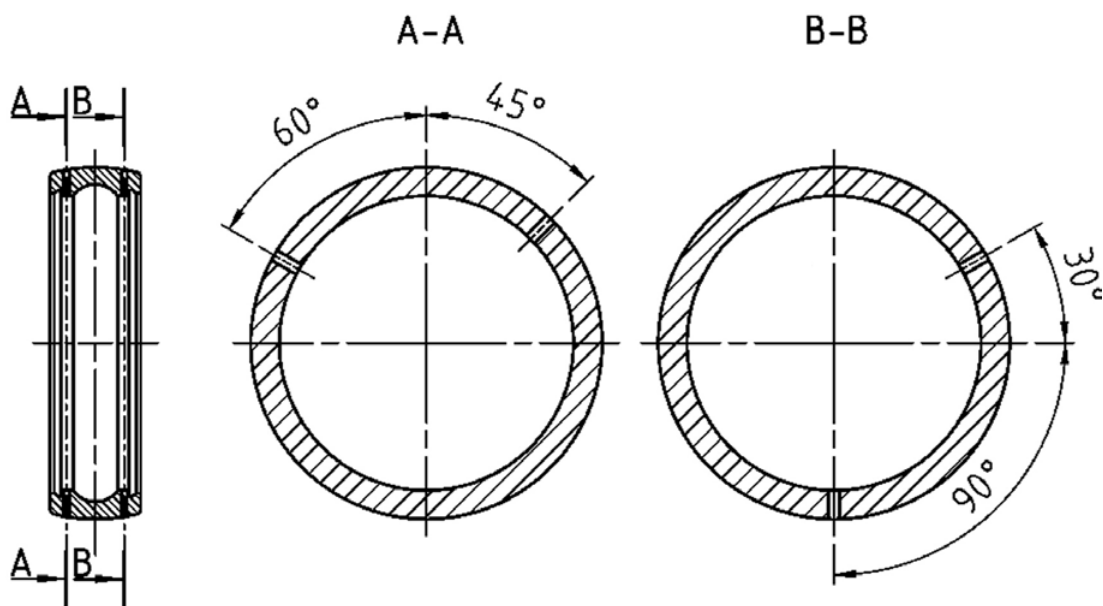

Schmiernippel

Die verwendeten Schmiernippel bestehen aus Stahl und sind verzinkt.

Folgende Größen der Schmiernippel werden eingesetzt:

M6x1, M8x1, M10x1 und R1/8“

Angaben über die passenden Schmiernippel zu den einzelnen Gehäusen finden Sie in den Maßtabellen.

Lieferzustand: Schmiernippel werden zusammen mit den Gehäuselagereinheiten geliefert. Sie sind nicht montiert. Die Schmierbohrung in den Gehäusen ist mit einem Kunststoffstopfen verschlossen.



Schmierfette

SNR-Gehäuselager-Einsätze sind werkseitig lebensdauergeschmiert. Ist ein Nachschmieren aufgrund erschwelter Betriebsbedingungen notwendig, so sollte ein Fett mit gleicher Basis und Konsistenz verwendet werden.

Die Schmierfette der SNR-Gehäuselager haben folgende technische Kennwerte:

Einsatzbereich des Schmierfettes	Basis des Schmierfettes	Temperaturbereich [°C]	Konsistenz DIN 51 818 NLGI-Klasse	Drehzahlkennwert (n · dm) [min ⁻¹ · mm]	Viskosität bei 40°C [mm ² /s]
Standard	Lithiumseife	-20 bis +120	II	500 000	100
Hohe Temperaturen (z.B. „T20“)	Perfluorpolyetheröl und PTFE	-40 bis +260	II	300 000	400
Tiefe Temperaturen (z.B. „T04“)	Lithiumseife	-60 bis +120	III	--	25

Gehäuse PE200 nachschmierbar

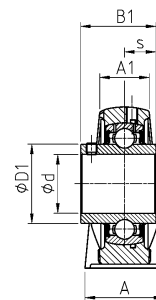
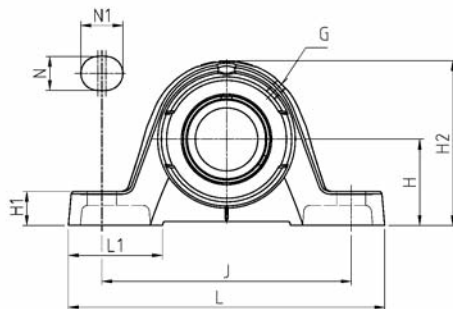
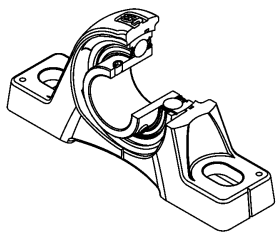

UCPE200

Wellendurchmesser
Einheit

Hauptabmessungen in mm

d [mm]		L	H	A1	A	J	N	N1	L1	H1	H2	s1	B	B1	s
12	UCPE201	130	33,3	19	32	97	11	19	40,0	14,5	64	-	-	31,0	12,7
	USPE201	125	30,2	18	30	95	11	19	38,0	10,0	57	-	-	22,0	6,0
	ESPE201	125	30,2	18	30	95	11	19	38,0	10,0	57	-	-	28,6	6,5
	EXPE201	130	33,3	19	32	97	11	19	40,0	14,5	64	-	-	43,5	17,0
15	UCPE202	130	33,3	19	32	97	11	19	40,0	14,5	64	-	-	31,0	12,7
	USPE202	125	30,2	18	30	95	11	19	38,0	10,0	57	-	-	22,0	6,0
	ESPE202	125	30,2	18	30	95	11	19	38,0	10,0	57	-	-	28,6	6,5
	EXPE202	130	33,3	19	32	97	11	19	40,0	14,5	64	-	-	43,5	17,0
17	UCPE203	130	33,3	19	32	97	11	19	40,0	14,5	64	-	-	31,0	12,7
	USPE203	125	30,2	18	30	95	11	19	38,0	10,0	57	-	-	22,0	6,0
	ESPE203	125	30,2	18	30	95	11	19	38,0	10,0	57	-	-	28,6	6,5
	EXPE203	130	33,3	19	32	97	11	19	40,0	14,5	64	-	-	43,5	17,0
20	UCPE204	130	33,3	19	32	97	11	19	40,0	14,5	64	-	-	31,0	12,7
	USPE204	130	33,3	19	32	97	11	19	40,0	14,5	64	-	-	25,0	7,0
	ESPE204	130	33,3	19	32	97	11	19	40,0	14,5	64	-	-	30,9	7,5
	EXPE204	130	33,3	19	32	97	11	19	40,0	14,5	64	-	-	43,5	17,0
	UKPE205H	130	36,5	21	36	103	11	19	39,0	14,5	70	18,5	35	-	-
25	UCPE205	130	36,5	21	36	103	11	19	39,0	14,5	70	-	-	34,0	14,3
	USPE205	130	36,5	21	36	103	11	19	39,0	14,5	70	-	-	27,0	7,5
	ESPE205	130	36,5	21	36	103	11	19	39,0	14,5	70	-	-	30,9	7,5
	EXPE205	130	36,5	21	36	103	11	19	39,0	14,5	70	-	-	44,3	17,4
	UKPE206H	158	42,9	25	40	118	14	22	47,0	17,0	82	20,5	38	-	-
30	UCPE206	158	42,9	25	40	118	14	22	47,0	17,0	82	-	-	38,1	15,9
	USPE206	158	42,9	25	40	118	14	22	47,0	17,0	82	-	-	30,0	8,0
	ESPE206	158	42,9	25	40	118	14	22	47,0	17,0	82	-	-	35,7	9,0
	EXPE206	158	42,9	25	40	118	14	22	47,0	17,0	82	-	-	48,3	18,2
	UKPE207H	163	47,6	27	45	126	14	21	49,0	19,0	93	22,5	43	-	-
35	UCPE207	163	47,6	27	45	126	14	21	49,0	19,0	93	-	-	42,9	17,5
	USPE207	163	47,6	27	45	126	14	21	49,0	19,0	93	-	-	32,0	8,5
	ESPE207	163	47,6	27	45	126	14	21	49,0	19,0	93	-	-	38,9	9,5
	EXPE207	163	47,6	27	45	126	14	21	49,0	19,0	93	-	-	51,1	18,8
	UKPE208H	179	49,2	30	48	138	14	26	53,0	19,0	99	24,5	46	-	-
40	UCPE208	179	49,2	30	48	138	14	26	53,0	19,0	99	-	-	49,2	19,0
	USPE208	179	49,2	30	48	138	14	26	53,0	19,0	99	-	-	34,0	9,0
	ESPE208	179	49,2	30	48	138	14	26	53,0	19,0	99	-	-	43,7	11,0
	EXPE208	179	49,2	30	48	138	14	26	53,0	19,0	99	-	-	56,3	21,4
	UKPE209H	192	54,0	32	48	150	14	29	54,5	21,5	107	26,0	50	-	-

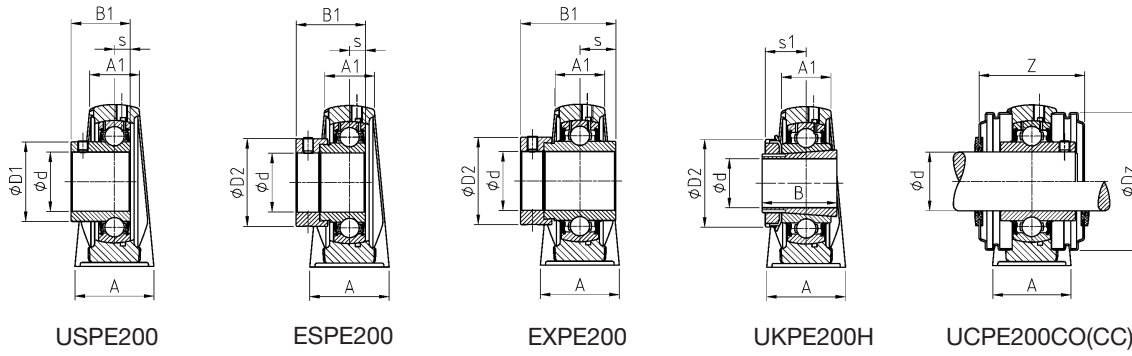

D1	D2	G	Z	Dz	Gehäuse	Einsatz	Schutzkappen offen *	Schutzkappen geschlossen **	Tragzahl dyn.	Tragzahl stat.	Gewicht	Wellendurch- messer
D1	D2	G	Z	Dz					C _r [kN]	C _{or} [kN]	[kg]	d [mm]
29,0	-	R1/8"	44,6	54,0	PE204	UC201	CO	CC	12,80	6,65	0,5	12
24,6	-	M6x1	40,6	46,0	PE203	US201	CO	CC	9,55	4,78	0,4	
-	28,6	M6x1	***	***	PE203	ES201	***	***	9,55	4,78	0,5	
-	33,3	R1/8"	***	***	PE204	EX201	***	***	12,80	6,65	0,6	
29,0	-	R1/8"	44,6	54,0	PE204	UC202	CO	CC	12,80	6,65	0,5	15
24,6	-	M6x1	40,6	46,0	PE203	US202	CO	CC	9,55	4,78	0,4	
-	28,6	M6x1	***	***	PE203	ES202	***	***	9,55	4,78	0,5	
-	33,3	R1/8"	***	***	PE204	EX202	***	***	12,80	6,65	0,6	
29,0	-	R1/8"	44,6	54,0	PE204	UC203	CO	CC	12,80	6,65	0,5	17
24,6	-	M6x1	40,6	46,0	PE203	US203	CO	CC	9,55	4,78	0,4	
-	28,6	M6x1	***	***	PE203	ES203	***	***	9,55	4,78	0,5	
-	33,3	R1/8"	***	***	PE204	EX203	***	***	12,80	6,65	0,6	
29,0	-	R1/8"	44,6	54,0	PE204	UC204	CO	CC	12,80	6,65	0,5	20
29,0	-	R1/8"	44,6	54,0	PE204	US204	CO	CC	12,80	6,65	0,5	
-	33,3	R1/8"	***	***	PE204	ES204	***	***	12,80	6,65	0,5	
-	33,3	R1/8"	***	***	PE204	EX204	***	***	12,80	6,65	0,6	
-	38,0	R1/8"	47,8	60,0	PE205	UK205 + H2305	CO	CC	14,00	7,88	0,8	
34,0	-	R1/8"	47,8	60,0	PE205	UC205	CO	CC	14,00	7,88	0,7	25
34,0	-	R1/8"	47,8	60,0	PE205	US205	CO	CC	14,00	7,88	0,7	
-	38,1	R1/8"	***	***	PE205	ES205	***	***	14,00	7,88	0,7	
-	38,1	R1/8"	***	***	PE205	EX205	***	***	14,00	7,88	0,8	
-	45,0	R1/8"	52,8	70,0	PE206	UK206 + H2306	CO	CC	19,50	11,20	1,2	
40,3	-	R1/8"	52,8	70,0	PE206	UC206	CO	CC	19,50	11,20	1,1	30
40,3	-	R1/8"	52,8	70,0	PE206	US206	CO	CC	19,50	11,20	1,1	
-	44,5	R1/8"	***	***	PE206	ES206	***	***	19,50	11,20	1,1	
-	44,5	R1/8"	***	***	PE206	EX206	***	***	19,50	11,20	1,2	
-	52,0	R1/8"	57,4	80,0	PE207	UK207 + H2307	CO	CC	25,70	15,20	1,6	
48,0	-	R1/8"	57,4	80,0	PE207	UC207	CO	CC	25,70	15,20	1,5	35
48,0	-	R1/8"	57,4	80,0	PE207	US207	CO	CC	25,70	15,20	1,5	
-	55,6	R1/8"	***	***	PE207	ES207	***	***	25,70	15,20	1,6	
-	55,6	R1/8"	***	***	PE207	EX207	***	***	25,70	15,20	1,7	
-	58,0	R1/8"	66,8	88,0	PE208	UK208 + H2308	CO	CC	29,60	18,20	1,9	
53,0	-	R1/8"	66,8	88,0	PE208	UC208	CO	CC	29,60	18,20	1,8	40
53,0	-	R1/8"	66,8	88,0	PE208	US208	CO	CC	29,60	18,20	1,8	
-	60,3	R1/8"	***	***	PE208	ES208	***	***	29,60	18,20	1,8	
-	60,3	R1/8"	***	***	PE208	EX208	***	***	29,60	18,20	2,0	
-	65,0	R1/8"	67,8	95,0	PE209	UK209 + H2309	CO	CC	31,85	20,80	2,3	

* = mit zwei offenen Schutzkappen für durchgehende Wellen: Nachsetzzeichen CO wie Bestellbeispiel Seite 6

** = mit einer offenen und einer geschlossenen Schutzkappe für Wellenenden: Nachsetzzeichen CC wie Bestellbeispiel Seite 6

*** = mit Schutzkappen für Einsätze mit Excentering auf Anfrage lieferbar



Gehäuse PE200 nachschmierbar

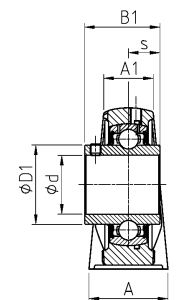
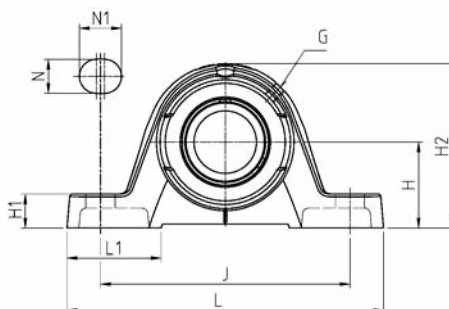
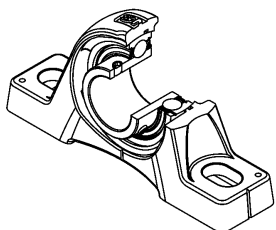

UCPE200

Wellendurchmesser
Einheit

Hauptabmessungen in mm

d [mm]		L	H	A1	A	J	N	N1	L1	H1	H2	s1	B	B1	s
45	UCPE209	192	54,0	32	48	150	14	29	54,5	21,5	107,0	-	-	49,2	19,0
	USPE209	192	54,0	32	48	150	14	29	54,5	21,5	107,0	-	-	41,2	10,2
	ESPE209	192	54,0	32	48	150	14	29	54,5	21,5	107,0	-	-	43,7	11,0
	EXPE209	192	54,0	32	48	150	14	29	54,5	21,5	107,0	-	-	56,3	21,4
	UKPE210H	200	57,2	34	54	158	18	23	61,0	21,5	115,0	27,5	55,0	-	-
50	UCPE210	200	57,2	34	54	158	18	23	61,0	21,5	115,0	-	-	51,6	19,0
	USPE210	200	57,2	34	54	158	18	23	61,0	21,5	115,0	-	-	43,5	10,9
	ESPE210	200	57,2	34	54	158	18	23	61,0	21,5	115,0	-	-	43,7	11,0
	EXPE210	200	57,2	34	54	158	18	23	61,0	21,5	115,0	-	-	62,7	24,6
	UKPE211H	222	63,5	35	60	176	18	30	68,0	22,5	124,5	29,0	59,0	-	-
55	UCPE211	222	63,5	35	60	176	18	30	68,0	22,5	124,5	-	-	55,6	22,2
	USPE211	222	63,5	35	60	176	18	30	68,0	22,5	124,5	-	-	45,3	11,8
	ESPE211	222	63,5	35	60	176	18	30	68,0	22,5	124,5	-	-	48,4	12,0
	EXPE211	222	63,5	35	60	176	18	30	68,0	22,5	124,5	-	-	71,3	27,7
	UKPE212H	240	69,9	42	60	190	18	28	71,0	25,0	140,0	31,0	62,0	-	-
60	UCPE212	240	69,9	42	60	190	18	28	71,0	25,0	140,0	-	-	65,1	25,4
	USPE212	240	69,9	42	60	190	18	28	71,0	25,0	140,0	-	-	53,7	14,9
	ESPE212	240	69,9	42	60	190	18	28	71,0	25,0	140,0	-	-	49,3	12,0
	EXPE212	240	69,9	42	60	190	18	28	71,0	25,0	140,0	-	-	77,7	30,9
	UKPE213H	260	79,4	44	65	203	22	28	77,0	27,5	156,0	32,0	65,0	-	-
65	UCPE213	260	79,4	44	65	203	22	28	77,0	27,5	156,0	-	-	65,1	25,4
	EXPE213	260	79,4	44	65	203	22	28	77,0	27,5	156,0	-	-	85,7	34,1
	UKPE215H	265	82,5	48	66	210	22	30	78,0	27,5	164,0	35,5	73,0	-	-
70	UCPE214	260	79,4	44	65	203	22	28	77,0	27,5	156,0	-	-	74,6	30,2
	EXPE214	260	79,4	44	65	203	22	28	77,0	27,5	156,0	-	-	85,7	34,1
	UKPE216H	290	89,0	55	78	232	26	34	90,0	30,0	175,0	39,0	78,0	-	-
75	UCPE215	265	82,5	48	66	210	22	30	78,0	27,5	164,0	-	-	77,8	33,3
	EXPE215	265	82,5	48	66	210	22	30	78,0	27,5	164,0	-	-	92,1	37,3
80	UCPE216	290	89,0	55	78	232	26	34	90,0	30,0	175,0	-	-	82,6	33,3
	EXPE216	290	89,0	55	78	232	26	34	90,0	30,0	175,0	-	-	95,2	37,3
	UKPE218H	330	101,6	55	85	268	27	35	99,0	35,0	200,0	42,0	86,0	-	-
90	UCPE218	330	101,6	55	85	268	27	35	99,0	35,0	200,0	-	-	96,0	39,7
	EXPE218	330	101,6	55	85	268	27	35	99,0	35,0	200,0	-	-	72,5	24,5

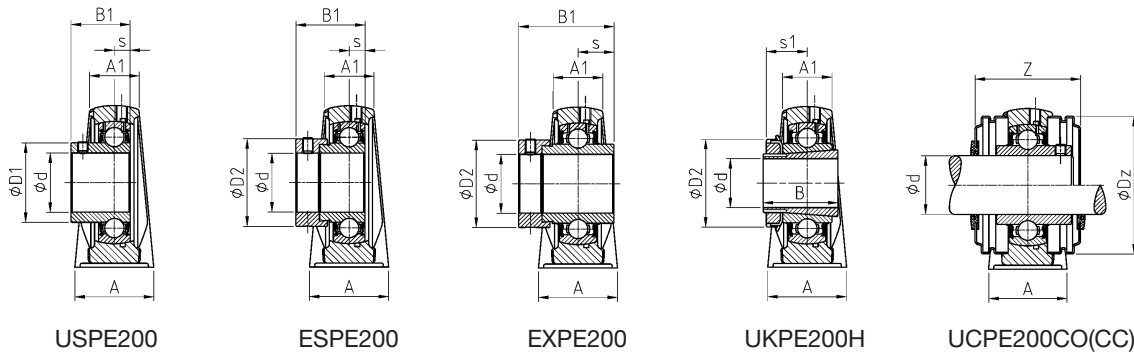

USPE200

ESPE200

EXPE200

UKPE200H

UCPE200CO(CC)

D1	D2	G	Z	Dz	Gehäuse	Einsatz	Schutzkappen offen *	Schutzkappen geschlossen **	Tragzahl dyn.	Tragzahl stat.	Gewicht [kg]	Wellendurch- messer [mm]
57,2	-	R1/8"	67,8	95,0	PE209	UC209	CO	CC	31,85	20,80	2,2	45
57,2	-	R1/8"	67,8	95,0	PE209	US209	CO	CC	31,85	20,80	2,1	45
-	63,5	R1/8"	***	***	PE209	ES209	***	***	31,85	20,80	2,2	45
-	63,5	R1/8"	***	***	PE209	EX209	***	***	31,85	20,80	2,4	45
-	70,0	R1/8"	74,6	100,0	PE210	UK210 + H2310	CO	CC	35,10	23,20	2,9	50
61,8	-	R1/8"	74,6	100,0	PE210	UC210	CO	CC	35,10	23,20	2,7	50
61,8	-	R1/8"	74,6	100,0	PE210	US210	CO	CC	35,10	23,20	2,7	50
-	69,9	R1/8"	***	***	PE210	ES210	***	***	35,10	23,20	2,7	50
-	69,9	R1/8"	***	***	PE210	EX210	***	***	35,10	23,20	2,9	50
-	75,0	R1/8"	75,2	110,0	PE211	UK211 + H2311	CO	CC	43,55	29,20	3,5	55
69,0	-	R1/8"	75,2	110,0	PE211	UC211	CO	CC	43,55	29,20	3,4	55
69,0	-	R1/8"	75,2	110,0	PE211	US211	CO	CC	43,55	29,20	3,4	55
-	76,2	R1/8"	***	***	PE211	ES211	***	***	43,55	29,20	3,2	55
-	76,2	R1/8"	***	***	PE211	EX211	***	***	43,55	29,20	3,7	55
-	80,0	R1/8"	87,8	120,0	PE212	UK212 + H2312	CO	CC	52,50	32,80	4,8	60
74,9	-	R1/8"	87,8	120,0	PE212	UC212	CO	CC	52,50	32,80	4,8	60
74,9	-	R1/8"	87,8	120,0	PE212	US212	CO	CC	52,50	32,80	4,6	60
-	84,2	R1/8"	***	***	PE212	ES212	***	***	52,50	32,80	4,5	60
-	84,2	R1/8"	***	***	PE212	EX212	***	***	52,50	32,80	5,1	60
-	85,0	R1/8"	88,8	132,0	PE213	UK213 + H2313	CO	CC	57,20	40,00	7,3	65
82,0	-	R1/8"	88,8	132,0	PE213	UC213	CO	CC	57,20	40,00	6,1	65
-	86,0	R1/8"	***	***	PE213	EX213	***	***	57,20	40,00	6,6	65
-	98,0	R1/8"	-	-	PE215	UK215 + H2315	-	-	66,00	49,50	6,8	70
86,5	-	R1/8"	-	-	PE214	UC214	-	-	62,00	45,00	6,1	70
-	96,8	R1/8"	-	-	PE214	EX214	-	-	62,00	45,00	6,6	70
-	105,0	R1/8"	-	-	PE216	UK216 + H2316	-	-	72,50	54,20	9,4	75
91,5	-	R1/8"	-	-	PE215	UC215	-	-	66,00	49,50	6,9	75
-	102,0	R1/8"	-	-	PE215	EX215	-	-	66,00	49,50	7,5	75
98,0	-	R1/8"	-	-	PE216	UC216	-	-	72,50	54,20	9,0	80
-	110,0	R1/8"	-	-	PE216	EX216	-	-	72,50	54,20	9,3	80
-	120,0	R1/8"	-	-	PE218	UK218 + H2318	-	-	96,00	71,50	13,6	90
111,0	-	R1/8"	-	-	PE218	UC218	-	-	96,00	71,50	13,3	90
-	120,0	R1/8"	-	-	PE218	EX218	-	-	96,00	71,50	13,8	90

* = mit zwei offenen Schutzkappen für durchgehende Wellen: Nachsetzzeichen CO wie Bestellbeispiel Seite 6

** = mit einer offenen und einer geschlossenen Schutzkappe für Wellenenden: Nachsetzzeichen CC wie Bestellbeispiel Seite 6

*** = mit Schutzkappen für Einsätze mit Excentring auf Anfrage lieferbar

Gehäuse PLE200 nachschmierbar

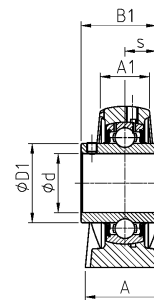
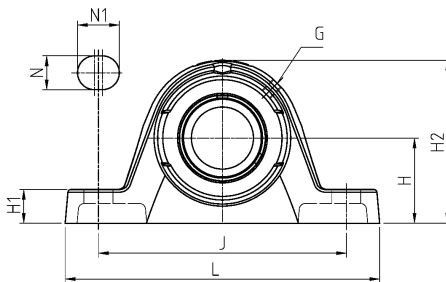
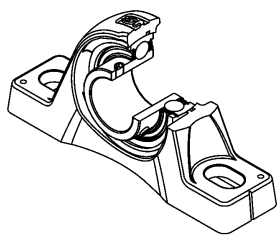

UCPLE200

Wellendurchmesser
Einheit

Hauptabmessungen in mm

d [mm]		L	H	A1	A	J	N	N1	H1	H2	s1	B	B1	s	D1
12	UCPLE201	126,5	31,8	22,5	32,0	94,5	11	17,0	12,5	63,7	-	-	31,0	12,7	29,0
	USPLE201	119,0	27,0	20,5	30,0	88,5	11	14,0	11,0	54,0	-	-	22,0	6,0	24,6
	ESPLE201	119,0	27,0	20,5	30,0	88,5	11	14,0	11,0	54,0	-	-	28,6	6,5	-
	EXPLE201	126,5	31,8	22,5	32,0	94,5	11	17,0	12,5	63,7	-	-	43,5	17,0	-
15	UCPLE202	126,5	31,8	22,5	32,0	94,5	11	17,0	12,5	63,7	-	-	31,0	12,7	29,0
	USPLE202	119,0	27,0	20,5	30,0	88,5	11	14,0	11,0	54,0	-	-	22,0	6,0	24,6
	ESPLE202	119,0	27,0	20,5	30,0	88,5	11	14,0	11,0	54,0	-	-	28,6	6,5	-
	EXPLE202	126,5	31,8	22,5	32,0	94,5	11	17,0	12,5	63,7	-	-	43,5	17,0	-
17	UCPLE203	126,5	31,8	22,5	32,0	94,5	11	17,0	12,5	63,7	-	-	31,0	12,7	29,0
	USPLE203	119,0	27,0	20,5	30,0	88,5	11	14,0	11,0	54,0	-	-	22,0	6,0	24,6
	ESPLE203	119,0	27,0	20,5	30,0	88,5	11	14,0	11,0	54,0	-	-	28,6	6,5	-
	EXPLE203	126,5	31,8	22,5	32,0	94,5	11	17,0	12,5	63,7	-	-	43,5	17,0	-
20	UCPLE204	126,5	31,8	22,5	32,0	94,5	11	17,0	12,5	63,7	-	-	31,0	12,7	29,0
	USPLE204	126,5	31,8	22,5	32,0	94,5	11	17,0	12,5	63,7	-	-	25,0	7,0	29,0
	ESPLE204	126,5	31,8	22,5	32,0	94,5	11	17,0	12,5	63,7	-	-	30,9	7,5	-
	EXPLE204	126,5	31,8	22,5	32,0	94,5	11	17,0	12,5	63,7	-	-	43,5	17,0	-
	UKPLE205H	139,0	33,3	24,5	36,5	104,2	11	17,0	12,8	67,8	18,5	35,0	-	-	-
25	UCPLE205	139,0	33,3	24,5	36,5	104,2	11	17,0	12,8	67,8	-	-	34,0	14,3	34,0
	USPLE205	139,0	33,3	24,5	36,5	104,2	11	17,0	12,8	67,8	-	-	27,0	7,5	34,0
	ESPLE205	139,0	33,3	24,5	36,5	104,2	11	17,0	12,8	67,8	-	-	30,9	7,5	-
	EXPLE205	139,0	33,3	24,5	36,5	104,2	11	17,0	12,8	67,8	-	-	44,3	17,4	-
	UKPLE206H	161,5	39,7	27,5	41,5	119,0	14	24,5	14,5	79,5	20,5	38,0	-	-	-
30	UCPLE206	161,5	39,7	27,5	41,5	119,0	14	24,5	14,5	79,5	-	-	38,1	15,9	40,3
	USPLE206	161,5	39,7	27,5	41,5	119,0	14	24,5	14,5	79,5	-	-	30,0	8,0	40,3
	ESPLE206	161,5	39,7	27,5	41,5	119,0	14	24,5	14,5	79,5	-	-	35,7	9,0	-
	EXPLE206	161,5	39,7	27,5	41,5	119,0	14	24,5	14,5	79,5	-	-	48,3	18,2	-
	UKPLE207H	166,0	46,2	30,5	44,5	129,0	14	21,5	16,0	91,5	22,5	43,0	-	-	-
35	UCPLE207	166,0	46,2	30,5	44,5	129,0	14	21,5	16,0	91,5	-	-	42,9	17,5	48,0
	USPLE207	166,0	46,2	30,5	44,5	129,0	14	21,5	16,0	91,5	-	-	32,0	8,5	48,0
	ESPLE207	166,0	46,2	30,5	44,5	129,0	14	21,5	16,0	91,5	-	-	38,9	9,5	-
	EXPLE207	166,0	46,2	30,5	44,5	129,0	14	21,5	16,0	91,5	-	-	51,1	18,8	-
	UKPLE208H	180,5	49,2	34,5	51,0	137,5	14	24,5	18,5	98,5	24,5	46,0	-	-	-

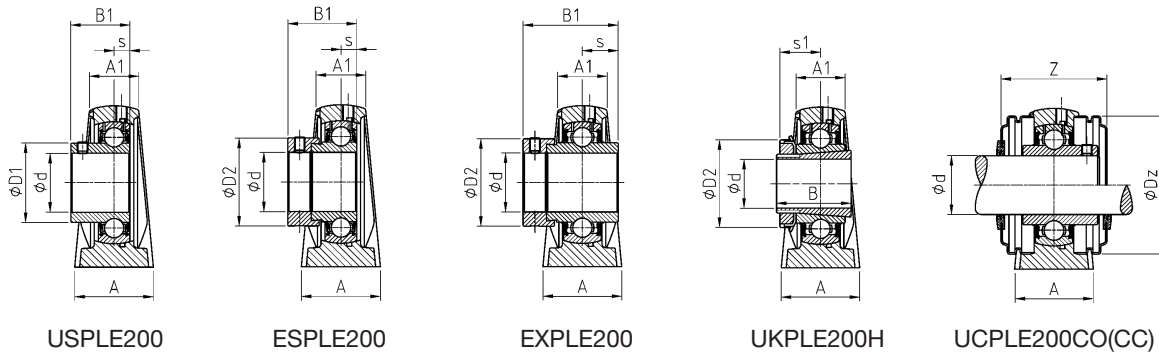

USPLE200

ESPLE200

EXPLE200

UKPLE200H

UCPLE200CO(CC)

				Gehäuse	Einsatz	Schutzkappen offen *	Schutzkappen geschlossen **	Tragzahl dyn.	Tragzahl stat.	Gewicht	Wellendurch- messer
D2	G	Z	Dz					C _r [kN]	C _{or} [kN]	[kg]	d [mm]
-	M6x1	44,6	54,0	PLE204	UC201	CO	CC	12,80	6,65	0,5	12
-	M6x1	40,6	46,0	PLE203	US201	CO	CC	9,55	4,78	0,4	
28,6	M6x1	***	***	PLE203	ES201	***	***	9,55	4,78	0,5	
33,3	M6x1	***	***	PLE204	EX201	***	***	12,80	6,65	0,6	
-	M6x1	44,6	54,0	PLE204	UC202	CO	CC	12,80	6,65	0,5	15
-	M6x1	40,6	46,0	PLE203	US202	CO	CC	9,55	4,78	0,4	
28,6	M6x1	***	***	PLE203	ES202	***	***	9,55	4,78	0,5	
33,3	M6x1	***	***	PLE204	EX202	***	***	12,80	6,65	0,6	
-	M6x1	44,6	54,0	PLE204	UC203	CO	CC	12,80	6,65	0,5	17
-	M6x1	40,6	46,0	PLE203	US203	CO	CC	9,55	4,78	0,4	
28,6	M6x1	***	***	PLE203	ES203	***	***	9,55	4,78	0,5	
33,3	M6x1	***	***	PLE204	EX203	***	***	12,80	6,65	0,6	
-	M6x1	44,6	54,0	PLE204	UC204	CO	CC	12,80	6,65	0,5	20
-	M6x1	42,6	54,0	PLE204	US204	CO	CC	12,80	6,65	0,5	
33,3	M6x1	***	***	PLE204	ES204	***	***	12,80	6,65	0,5	
33,3	M6x1	***	***	PLE204	EX204	***	***	12,80	6,65	0,6	
38,0	M6x1	47,8	60,0	PLE205	UK205 + H2305	CO	CC	14,00	7,88	0,8	25
-	M6x1	47,8	60,0	PLE205	UC205	CO	CC	14,00	7,88	0,7	
-	M6x1	47,8	60,0	PLE205	US205	CO	CC	14,00	7,88	0,7	
38,1	M6x1	***	***	PLE205	ES205	***	***	14,00	7,88	0,7	
38,1	M6x1	***	***	PLE205	EX205	***	***	14,00	7,88	0,8	
45,0	M6x1	52,8	70,0	PLE206	UK206 + H2306	CO	CC	19,50	11,20	1,2	
-	M6x1	52,8	70,0	PLE206	UC206	CO	CC	19,50	11,20	1,1	30
-	M6x1	52,8	70,0	PLE206	US206	CO	CC	19,50	11,20	1,1	
44,5	M6x1	***	***	PLE206	ES206	***	***	19,50	11,20	1,1	
44,5	M6x1	***	***	PLE206	EX206	***	***	19,50	11,20	1,2	
52,0	M6x1	57,4	80,0	PLE207	UK207 + H2307	CO	CC	25,70	15,20	1,6	35
-	M6x1	57,4	80,0	PLE207	UC207	CO	CC	25,70	15,20	1,5	
-	M6x1	57,4	80,0	PLE207	US207	CO	CC	25,70	15,20	1,5	
55,6	M6x1	***	***	PLE207	ES207	***	***	25,70	15,20	1,6	
55,6	M6x1	***	***	PLE207	EX207	***	***	25,70	15,20	1,7	
58,0	M6x1	66,8	88,0	PLE208	UK208 + H2308	CO	CC	29,60	18,20	1,9	

* = mit zwei offenen Schutzkappen für durchgehende Wellen: Nachsetzzeichen CO wie Bestellbeispiel Seite 6

** = mit einer offenen und einer geschlossenen Schutzkappe für Wellenenden: Nachsetzzeichen CC wie Bestellbeispiel Seite 6

*** = mit Schutzkappen für Einsätze mit Excentring auf Anfrage lieferbar

Gehäuse PLE200 nachschmierbar

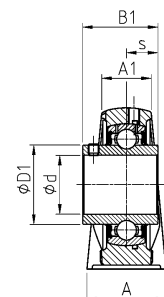
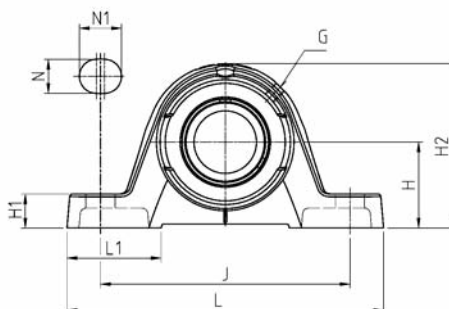
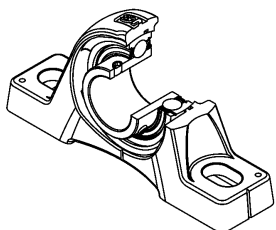

UCPLE200

Wellendurchmesser
Einheit

Hauptabmessungen in mm

d [mm]		L	H	A1	A	J	N	N1	H1	H2	s1	B	B1	s	D1
40	UCPLE208	180,5	49,2	34,5	51,0	137,5	14	24,5	18,5	98,5	-	-	49,2	19,0	53,0
	USPLE208	180,5	49,2	34,5	51,0	137,5	14	24,5	18,5	98,5	-	-	34,0	9,0	53,0
	ESPLE208	180,5	49,2	34,5	51,0	137,5	14	24,5	18,5	98,5	-	-	43,7	11,0	-
	EXPLE208	180,5	49,2	34,5	51,0	137,5	14	24,5	18,5	98,5	-	-	56,3	21,4	-
	UKPLE209H	197,5	52,4	35,0	54,0	151,5	14	24,0	18,4	106,4	26,0	50,0	-	-	-
45	UCPLE209	197,5	52,4	35,0	54,0	151,5	14	24,0	18,4	106,4	-	-	49,2	19,0	57,2
	USPLE209	197,5	52,4	35,0	54,0	151,5	14	24,0	18,4	106,4	-	-	41,2	10,2	57,2
	ESPLE209	197,5	52,4	35,0	54,0	151,5	14	24,0	18,4	106,4	-	-	43,7	11,0	-
	EXPLE209	197,5	52,4	35,0	54,0	151,5	14	24,0	18,4	106,4	-	-	56,3	21,4	-
	UKPLE210H	214,0	55,6	36,0	55,0	164,0	14	27,0	19,3	114,0	27,5	55,0	-	-	-
50	UCPLE210	214,0	55,6	36,0	55,0	164,0	14	27,0	19,3	114,0	-	-	51,6	19,0	61,8
	USPLE210	214,0	55,6	36,0	55,0	164,0	14	27,0	19,3	114,0	-	-	43,5	10,9	61,8
	ESPLE210	214,0	55,6	36,0	55,0	164,0	14	27,0	19,3	114,0	-	-	43,7	11,0	-
	EXPLE210	214,0	55,6	36,0	55,0	164,0	14	27,0	19,3	114,0	-	-	62,7	24,6	-
	UKPLE211H	219,5	61,3	39,5	60,0	170,5	18	26,0	23,2	128,0	29,0	59,0	-	-	-
55	UCPLE211	219,5	61,3	39,5	60,0	170,5	18	26,0	23,2	128,0	-	-	55,6	22,2	69,0
	USPLE211	219,5	61,3	39,5	60,0	170,5	18	26,0	23,2	128,0	-	-	45,3	11,8	69,0
	ESPLE211	219,5	61,3	39,5	60,0	170,5	18	26,0	23,2	128,0	-	-	48,4	12,0	-
	EXPLE211	219,5	61,3	39,5	60,0	170,5	18	26,0	23,2	128,0	-	-	71,3	27,7	-
	UKPLE212H	245,0	68,3	50,8	79,4	193,7	18	29,1	28,6	138,1	31,0	62,0	-	-	-
60	UCPLE212	245,0	68,3	50,8	79,4	193,7	18	29,1	28,6	138,1	-	-	65,1	25,4	74,9
	USPLE212	245,0	68,3	50,8	79,4	193,7	18	29,1	28,6	138,1	-	-	53,7	14,9	74,9
	ESPLE212	245,0	68,3	50,8	79,4	193,7	18	29,1	28,6	138,1	-	-	49,3	12,0	-
	EXPLE212	245,0	68,3	50,8	79,4	193,7	18	29,1	28,6	138,1	-	-	77,7	30,9	-

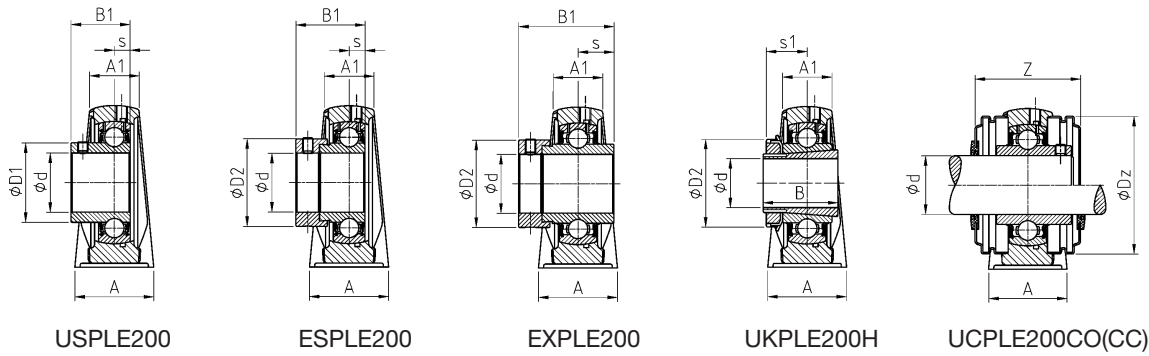

				Gehäuse	Einsatz	Schutzkappen offen *	Schutzkappen geschlossen **	Tragzahl dyn.	Tragzahl stat.	Gewicht	Wellendurch- messer
D2	G	Z	Dz					C _r [kN]	C _{or} [kN]	[kg]	d [mm]
-	M6x1	66,8	88,0	PLE208	UC208	CO	CC	29,60	18,20	1,8	40
-	M6x1	66,8	88,0	PLE208	US208	CO	CC	29,60	18,20	1,8	
60,3	M6x1	***	***	PLE208	ES208	***	***	29,60	18,20	1,8	
60,3	M6x1	***	***	PLE208	EX208	***	***	29,60	18,20	2,0	
65,0	M6x1	67,8	95,0	PLE209	UK209 + H2309	CO	CC	31,85	20,80	2,3	
-	M6x1	67,8	95,0	PLE209	UC209	CO	CC	31,85	20,80	2,2	45
-	M6x1	67,8	95,0	PLE209	US209	CO	CC	31,85	20,80	2,1	
63,5	M6x1	***	***	PLE209	ES209	***	***	31,85	20,80	2,2	
63,5	M6x1	***	***	PLE209	EX209	***	***	31,85	20,80	2,4	
70,0	M6x1	74,6	100,0	PLE210	UK210 + H2310	CO	CC	35,10	23,20	2,9	
-	M6x1	74,6	100,0	PLE210	UC210	CO	CC	35,10	23,20	2,7	50
-	M6x1	74,6	100,0	PLE210	US210	CO	CC	35,10	23,20	2,7	
69,9	M6x1	***	***	PLE210	ES210	***	***	35,10	23,20	2,7	
69,9	M6x1	***	***	PLE210	EX210	***	***	35,10	23,20	2,9	
75,0	M6x1	75,2	110,0	PLE211	UK211 + H2311	CO	CC	43,55	29,20	3,5	
-	M6x1	75,2	110,0	PLE211	UC211	CO	CC	43,55	29,20	3,4	55
-	M6x1	75,2	110,0	PLE211	US211	CO	CC	43,55	29,20	3,4	
76,2	M6x1	***	***	PLE211	ES211	***	***	43,55	29,20	3,2	
76,2	M6x1	***	***	PLE211	EX211	***	***	43,55	29,20	3,7	
80,0	M6x1	87,8	120,0	PLE212	UK212 + H2312	CO	CC	52,50	32,80	4,8	
-	M6x1	87,8	120,0	PLE212	UC212	CO	CC	52,50	32,80	4,8	60
-	M6x1	87,8	120,0	PLE212	US212	CO	CC	52,50	32,80	4,6	
84,2	M6x1	***	***	PLE212	ES212	***	***	52,50	32,80	4,5	
84,2	M6x1	***	***	PLE212	EX212	***	***	52,50	32,80	5,1	

* = mit zwei offenen Schutzkappen für durchgehende Wellen: Nachsetzzeichen CO wie Bestellbeispiel Seite 6

** = mit einer offenen und einer geschlossenen Schutzkappe für Wellenenden: Nachsetzzeichen CC wie Bestellbeispiel Seite 6

*** = mit Schutzkappen für Einsätze mit Excenterring auf Anfrage lieferbar

Gehäuse P200 nachschmierbar
P300 nachschmierbar

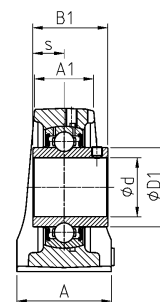
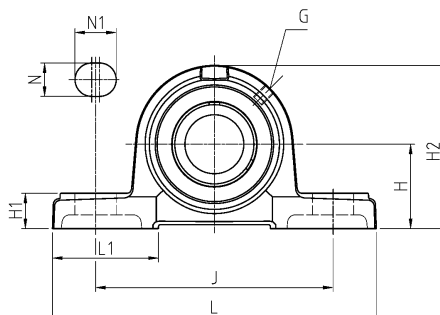
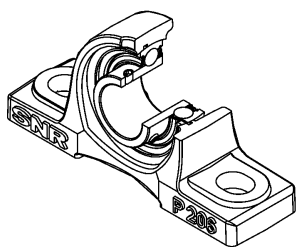

UCP200
UCP300

Wellendurchmesser
Einheit

Hauptabmessungen in mm

d [mm]		L	H	A1	A	J	N	N1	L1	H1	H2	s1	B	B1	s
12	UCP201	127	33,3	22	38	95	13	19	42	15	65	-	-	31,0	12,7
	USP201	127	30,2	22	38	95	13	19	42	15	62	-	-	22,0	6,0
	ESP201	127	30,2	22	38	95	13	19	42	15	62	-	-	28,6	6,5
	EXP201	127	33,3	22	38	95	13	19	42	15	65	-	-	43,5	17,0
15	UCP202	127	33,3	22	38	95	13	19	42	15	65	-	-	31,0	12,7
	USP202	127	30,2	22	38	95	13	19	42	15	62	-	-	22,0	6,0
	ESP202	127	30,2	22	38	95	13	19	42	15	62	-	-	28,6	6,5
	EXP202	127	33,3	22	38	95	13	19	42	15	65	-	-	43,5	17,0
17	UCP203	127	33,3	22	38	95	13	19	42	15	65	-	-	31,0	12,7
	USP203	127	30,2	22	38	95	13	19	42	15	62	-	-	22,0	6,0
	ESP203	127	30,2	22	38	95	13	19	42	15	62	-	-	28,6	6,5
	EXP203	127	33,3	22	38	95	13	19	42	15	65	-	-	43,5	17,0
20	UCP204	127	33,3	22	38	95	13	19	42	15	65	-	-	31,0	12,7
	USP204	127	33,3	22	38	95	13	19	42	15	65	-	-	25,0	7,0
	ESP204	127	33,3	22	38	95	13	19	42	15	65	-	-	30,9	7,5
	EXP204	127	33,3	22	38	95	13	19	42	15	65	-	-	43,5	17,0
	UKP205H	140	36,5	26	38	105	13	19	42	16	70	18,5	35,0	-	-
	UKP305H	175	45,0	32	45	132	17	20	54	15	85	21,5	35,0	-	-
25	UCP205	140	36,5	26	38	105	13	19	42	16	70	-	-	34,0	14,3
	USP205	140	36,5	26	38	105	13	19	42	16	70	-	-	27,0	7,5
	ESP205	140	36,5	26	38	105	13	19	42	16	70	-	-	30,9	7,5
	EXP205	140	36,5	26	38	105	13	19	42	16	70	-	-	44,3	17,4
	UKP206H	165	42,9	30	48	121	17	21	54	18	83	20,5	38,0	-	-
	UCP305	175	45,0	32	45	132	17	20	54	15	85	-	-	38,0	15,0
	EXP305	175	45,0	32	45	132	17	20	54	15	85	-	-	46,8	16,7
	UKP306H	180	50,0	36	50	140	17	20	54	18	95	23,0	38,0	-	-
30	UCP206	165	42,9	30	48	121	17	21	54	18	83	-	-	38,1	15,9
	USP206	165	42,9	30	48	121	17	21	54	18	83	-	-	30,0	8,0
	ESP206	165	42,9	30	48	121	17	21	54	18	83	-	-	35,7	9,0
	EXP206	165	42,9	30	48	121	17	21	54	18	83	-	-	48,3	18,2
	UKP207H	167	47,6	31	48	127	17	21	54	19	94	22,5	43,0	-	-
	UCP306	180	50,0	36	50	140	17	20	54	18	95	-	-	43,0	17,0
	EXP306	180	50,0	36	50	140	17	20	54	18	95	-	-	50,0	17,5
	UKP307H	210	56,0	38	56	160	17	25	60	20	106	25,5	43,0	-	-

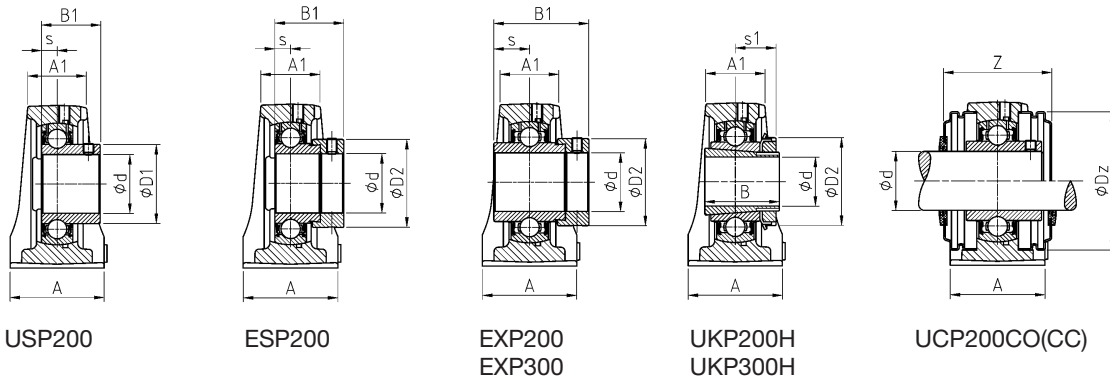

USP200

ESP200

EXP200
EXP300UKP200H
UKP300H

UCP200CO(CC)

D1	D2	G	Z	Dz	Gehäuse	Einsatz	Schutzkappen offen *	Schutzkappen geschlossen **	Tragzahl dyn.	Tragzahl stat.	Gewicht	Wellendurch- messer
D1	D2	G	Z	Dz					C _r [kN]	C _{or} [kN]	[kg]	d [mm]
29,0	-	M6x1	45,0	54,0	P204	UC201	CO	CC	12,80	6,65	0,7	12
24,6	-	M6x1	45,0	46,0	P203	US201	CO	CC	9,55	4,78	0,7	
-	28,6	M6x1	***	***	P203	ES201	***	***	9,55	4,78	0,7	
-	33,3	M6x1	***	***	P204	EX201	***	***	12,80	6,65	0,8	
29,0	-	M6x1	45,0	54,0	P204	UC202	CO	CC	12,80	6,65	0,7	15
24,6	-	M6x1	45,0	46,0	P203	US202	CO	CC	9,55	4,78	0,6	
-	28,6	M6x1	***	***	P203	ES202	***	***	9,55	4,78	0,7	
-	33,3	M6x1	***	***	P204	EX202	***	***	12,80	6,65	0,8	
29,0	-	M6x1	45,0	54,0	P204	UC203	CO	CC	12,80	6,65	0,7	17
24,6	-	M6x1	45,0	46,0	P203	US203	CO	CC	9,55	4,78	0,6	
-	28,6	M6x1	***	***	P203	ES203	***	***	9,55	4,78	0,7	
-	33,3	M6x1	***	***	P204	EX203	***	***	12,80	6,65	0,8	
29,0	-	M6x1	45,0	54,0	P204	UC204	CO	CC	12,80	6,65	0,7	20
29,0	-	M6x1	45,0	54,0	P204	US204	CO	CC	12,80	6,65	0,7	
-	33,3	M6x1	***	***	P204	ES204	***	***	12,80	6,65	0,7	
-	33,3	M6x1	***	***	P204	EX204	***	***	12,80	6,65	0,8	
-	38,0	M6x1	48,0	60,0	P205	UK205 + H2305	CO	CC	14,00	7,88	0,8	
-	38,0	M6x1	-	-	P305	UK305 + H2305	-	-	22,36	11,50	1,6	
34,0	-	M6x1	48,0	60,0	P205	UC205	CO	CC	14,00	7,88	0,8	25
34,0	-	M6x1	48,0	60,0	P205	US205	CO	CC	14,00	7,88	0,8	
-	38,1	M6x1	***	***	P205	ES205	***	***	14,00	7,88	0,8	
-	38,1	M6x1	***	***	P205	EX205	***	***	14,00	7,88	0,9	
-	45,0	M6x1	53,0	70,0	P206	UK206 + H2306	CO	CC	19,50	11,20	1,4	
35,4	-	M6x1	-	-	P305	UC305	-	-	22,36	11,50	1,4	
-	42,8	M6x1	-	-	P305	EX305	-	-	22,36	11,50	1,5	
-	45,0	M6x1	-	-	P306	UK306 + H2306	-	-	27,00	15,20	2,0	
40,3	-	M6x1	53,0	70,0	P206	UC206	CO	CC	19,50	11,20	1,4	30
40,3	-	M6x1	53,0	70,0	P206	US206	CO	CC	19,50	11,20	1,3	
-	44,5	M6x1	***	***	P206	ES206	***	***	19,50	11,20	1,4	
-	44,5	M6x1	***	***	P206	EX206	***	***	19,50	11,20	1,5	
-	52,0	M6x1	60,0	80,0	P207	UK207 + H2307	CO	CC	25,70	15,20	1,8	
44,6	-	M6x1	-	-	P306	UC306	-	-	27,00	15,20	1,9	
-	50,0	M6x1	-	-	P306	EX306	-	-	27,00	15,20	2,1	
-	52,0	M6x1	-	-	P307	UK307 + H2307	-	-	33,50	19,20	2,8	

* = mit zwei offenen Schutzkappen für durchgehende Wellen: Nachsetzzeichen CO wie Bestellbeispiel Seite 6

** = mit einer offenen und einer geschlossenen Schutzkappe für Wellenenden: Nachsetzzeichen CC wie Bestellbeispiel Seite 6

*** = mit Schutzkappen für Einsätze mit Excenterring auf Anfrage lieferbar

Gehäuse P200 nachschmierbar
P300 nachschmierbar

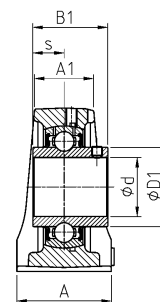
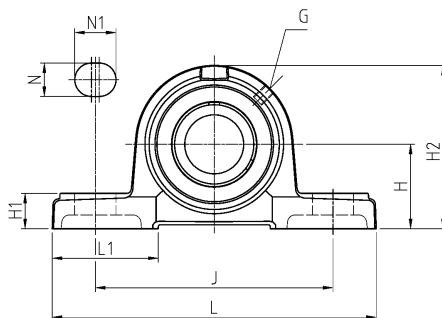
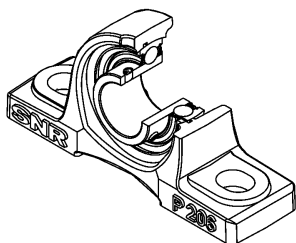

UCP200
UCP300

Wellendurchmesser
Einheit

Hauptabmessungen in mm

d [mm]		L	H	A1	A	J	N	N1	L1	H1	H2	s1	B	B1	s
35	UCP207	167	47,6	31	48	127	17	21	54	19	94	-	-	42,9	17,5
	USP207	167	47,6	31	48	127	17	21	54	19	94	-	-	32,0	8,5
	ESP207	167	47,6	31	48	127	17	21	54	19	94	-	-	38,9	9,5
	EXP207	167	47,6	31	48	127	17	21	54	19	94	-	-	51,1	18,8
	UKP208H	184	49,2	34	54	137	17	23	52	19	100	24,5	46,0	-	-
	UCP307	210	56,0	38	56	160	17	25	60	20	106	-	-	48,0	19,0
	EXP307	210	56,0	38	56	160	17	25	60	20	106	-	-	51,6	18,3
	UKP308H	220	60,0	42	60	170	17	27	60	22	116	27,5	46,0	-	-
40	UCP208	184	49,2	34	54	137	17	23	52	19	100	-	-	49,2	19,0
	USP208	184	49,2	34	54	137	17	23	52	19	100	-	-	34,0	9,0
	ESP208	184	49,2	34	54	137	17	23	52	19	100	-	-	43,7	11,0
	EXP208	184	49,2	34	54	137	17	23	52	19	100	-	-	56,3	21,4
	UKP209H	190	54,0	37	54	146	17	23	60	20	108	26,0	50,0	-	-
	UCP308	220	60,0	42	60	170	17	27	60	22	116	-	-	52,0	19,0
	EXP308	220	60,0	42	60	170	17	27	60	22	116	-	-	57,1	19,8
	UKP309H	245	67,0	45	67	190	20	30	65	24	129	30,0	50,0	-	-
45	UCP209	190	54,0	37	54	146	17	23	60	20	108	-	-	49,2	19,0
	USP209	190	54,0	37	54	146	17	23	60	20	108	-	-	41,2	10,2
	ESP209	190	54,0	37	54	146	17	23	60	20	108	-	-	43,7	11,0
	EXP209	190	54,0	37	54	146	17	23	60	20	108	-	-	56,3	21,4
	UKP210H	206	57,2	39	60	159	20	25	65	22	114	27,5	55,0	-	-
	UCP309	245	67,0	45	67	190	20	30	65	24	129	-	-	57,0	22,0
	EXP309	245	67,0	45	67	190	20	30	65	24	129	-	-	58,7	19,8
	UKP310H	275	75,0	48	75	212	20	35	75	27	143	32,0	55,0	-	-
50	UCP210	206	57,2	39	60	159	20	25	65	22	114	-	-	51,6	19,0
	USP210	206	57,2	39	60	159	20	25	65	22	114	-	-	43,5	10,9
	ESP210	206	57,2	39	60	159	20	25	65	22	114	-	-	43,7	11,0
	EXP210	206	57,2	39	60	159	20	25	65	22	114	-	-	62,7	24,6
	UKP211H	219	63,5	40	60	171	20	25	70	22	126	29,0	59,0	-	-
	UCP310	275	75,0	48	75	212	20	35	75	27	143	-	-	61,0	22,0
	EXP310	275	75,0	48	75	212	20	35	75	27	143	-	-	66,6	24,6
	UKP311H	310	80,0	51	80	236	20	38	85	30	154	34,0	59,0	-	-

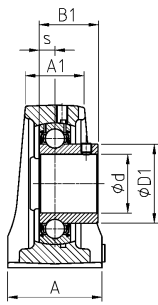

USP200

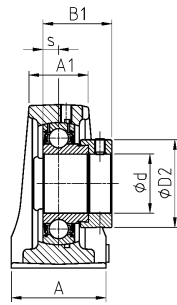

ESP200

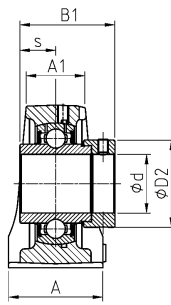
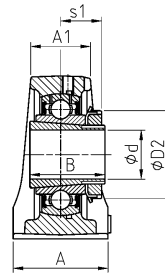
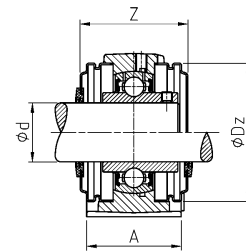
EXP200
EXP300UKP200H
UKP300H

UCP200CO(CC)

D1	D2	G	Z	Dz	Gehäuse	Einsatz	Schutzkappen offen *	Schutzkappen geschlossen **	Tragzahl dyn.	Tragzahl stat.	Gewicht	Wellendurch- messer
D1	D2	G	Z	Dz					C_r [kN]	C_{or} [kN]	[kg]	d [mm]
48,0	-	M6x1	60,0	80,0	P207	UC207	CO	CC	25,70	15,20	1,8	35
48,0	-	M6x1	60,0	80,0	P207	US207	CO	CC	25,70	15,20	1,7	
-	55,6	M6x1	***	***	P207	ES207	***	***	25,70	15,20	1,8	
-	55,6	M6x1	***	***	P207	EX207	***	***	25,70	15,20	1,9	
-	58,0	M6x1	69,0	88,0	P208	UK208 + H2308	CO	CC	29,60	18,20	2,2	
48,9	-	M6x1	-	-	P307	UC307	-	-	33,50	19,20	2,6	
-	55,0	M6x1	-	-	P307	EX307	-	-	33,50	19,20	2,7	
-	58,0	M6x1	-	-	P308	UK308 + H2308	-	-	40,56	24,00	3,4	
53,0	-	M6x1	69,0	88,0	P208	UC208	CO	CC	29,60	18,20	2,1	40
53,0	-	M6x1	69,0	88,0	P208	US208	CO	CC	29,60	18,20	2,1	
-	60,3	M6x1	***	***	P208	ES208	***	***	29,60	18,20	2,1	
-	60,3	M6x1	***	***	P208	EX208	***	***	29,60	18,20	2,3	
-	65,0	M6x1	69,0	95,0	P209	UK209 + H2309	CO	CC	31,85	20,80	2,5	
56,5	-	M6x1	-	-	P308	UC308	-	-	40,56	24,00	3,3	
-	63,5	M6x1	-	-	P308	EX308	-	-	40,56	24,00	3,5	
-	65,0	M6x1	-	-	P309	UK309 + H2309	-	-	53,00	31,80	4,8	
57,2	-	M6x1	69,0	95,0	P209	UC209	CO	CC	31,85	20,80	2,4	45
57,2	-	M6x1	69,0	95,0	P209	US209	CO	CC	31,85	20,80	2,4	
-	63,5	M6x1	***	***	P209	ES209	***	***	31,85	20,80	2,4	
-	63,5	M6x1	***	***	P209	EX209	***	***	31,85	20,80	2,6	
-	70,0	M6x1	76,0	100,0	P210	UK210 + H2310	CO	CC	35,10	23,20	3,1	
61,8	-	M6x1	-	-	P309	UC309	-	-	53,00	31,80	4,6	
-	70,0	M6x1	-	-	P309	EX309	-	-	53,00	31,80	4,7	
-	70,0	M6x1	-	-	P310	UK310 + H2310	-	-	62,00	37,80	6,2	
61,8	-	M6x1	76,0	100,0	P210	UC210	CO	CC	35,10	23,20	3,0	50
61,8	-	M6x1	76,0	100,0	P210	US210	CO	CC	35,10	23,20	2,9	
-	69,9	M6x1	***	***	P210	ES210	***	***	35,10	23,20	3,0	
-	69,9	M6x1	***	***	P210	EX210	***	***	35,10	23,20	3,2	
-	75,0	M6x1	77,0	110,0	P211	UK211 + H2311	CO	CC	43,55	29,20	3,7	
68,7	-	M6x1	-	-	P310	UC310	-	-	62,00	37,80	6,1	
-	76,2	M6x1	-	-	P310	EX310	-	-	62,00	37,80	6,3	
-	75,0	M6x1	-	-	P311	UK311 + H2311	-	-	71,50	44,80	7,9	

* = mit zwei offenen Schutzkappen für durchgehende Wellen: Nachsetzzeichen CO wie Bestellbeispiel Seite 6

** = mit einer offenen und einer geschlossenen Schutzkappe für Wellenenden: Nachsetzzeichen CC wie Bestellbeispiel Seite 6

*** = mit Schutzkappen für Einsätze mit Excenterring auf Anfrage lieferbar

Gehäuse P200 nachschmierbar
P300 nachschmierbar

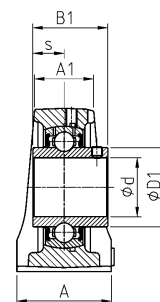
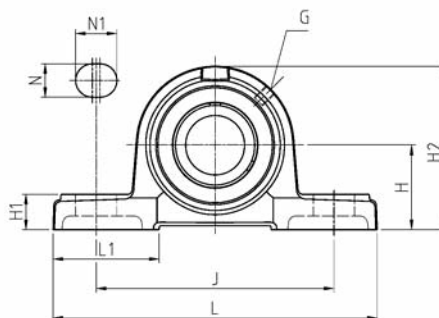
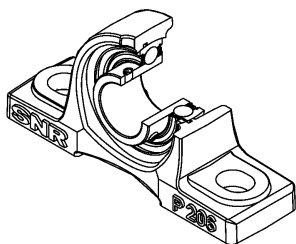

UCP200
UCP300

Wellendurchmesser
Einheit

Hauptabmessungen in mm

d [mm]		L	H	A1	A	J	N	N1	L1	H1	H2	s1	B	B1	s
55	UCP211	219	63,5	40	60	171	20	25	70	22	126	-	-	55,6	22,2
	USP211	219	63,5	40	60	171	20	25	70	22	126	-	-	45,3	11,8
	ESP211	219	63,5	40	60	171	20	25	70	22	126	-	-	48,4	12,0
	EXP211	219	63,5	40	60	171	20	25	70	22	126	-	-	71,3	27,7
	UKP212H	241	69,8	44	70	184	20	25	70	25	138	31,0	62,0	-	-
	UCP311	310	80,0	51	80	236	20	38	85	30	154	-	-	66,0	25,0
	EXP311	310	80,0	51	80	236	20	38	85	30	154	-	-	73,0	27,8
	UKP312H	330	85,0	54	85	250	25	38	95	32	165	36,5	62,0	-	-
60	UCP212	241	69,8	44	70	184	20	25	70	25	138	-	-	65,1	25,4
	USP212	241	69,8	44	70	184	20	25	70	25	138	-	-	53,7	14,9
	ESP212	241	69,8	44	70	184	20	25	70	25	138	-	-	49,3	12,0
	EXP212	241	69,8	44	70	184	20	25	70	25	138	-	-	77,7	30,9
	UKP213H	265	76,2	46	70	203	25	29	77	27	150	32,0	65,0	-	-
	UCP312	330	85,0	54	85	250	25	38	95	32	165	-	-	71,0	26,0
	EXP312	330	85,0	54	85	250	25	38	95	32	165	-	-	79,4	31,0
	UKP313H	340	90,0	57	90	260	25	38	105	33	176	38,5	65,0	-	-
65	UCP213	265	76,2	46	70	203	25	29	77	27	150	-	-	65,1	25,4
	EXP213	265	76,2	46	70	203	25	29	77	27	150	-	-	85,7	34,1
	UKP215H	275	82,6	48	74	217	25	31	85	28	163	35,5	73,0	-	-
	UCP313	340	90,0	57	90	260	25	38	105	33	176	-	-	75,0	30,0
	EXP313	340	90,0	57	90	260	25	38	105	33	176	-	-	85,7	32,5
	UKP315H	380	100,0	63	100	290	27	40	110	35	198	42,5	73,0	-	-
70	UCP214	266	79,4	48	72	210	25	31	83	27	156	-	-	74,6	30,2
	EXP214	266	79,4	48	72	210	25	31	83	27	156	-	-	85,7	34,1
	UKP216H	292	88,9	51	78	232	25	31	91	30	175	39,0	78,0	-	-
	UCP314	360	95,0	60	90	280	27	40	105	35	187	-	-	78,0	33,0
	EXP314	360	95,0	60	90	280	27	40	105	35	187	-	-	92,1	34,2
	UKP316H	400	106,0	66	110	300	27	40	110	40	210	44,5	78,0	-	-
75	UCP215	275	82,6	48	74	217	25	31	85	28	163	-	-	77,8	33,3
	EXP215	275	82,6	48	74	217	25	31	85	28	163	-	-	92,1	37,3
	UKP217H	310	95,2	53	83	247	25	31	96	32	187	40,0	82,0	-	-
	UCP315	380	100,0	63	100	290	27	40	110	35	198	-	-	82,0	32,0
	EXP315	380	100,0	63	100	290	27	40	110	35	198	-	-	100,0	37,3
	UKP317H	420	112,0	69	110	320	33	45	120	40	220	48,0	82,0	-	-

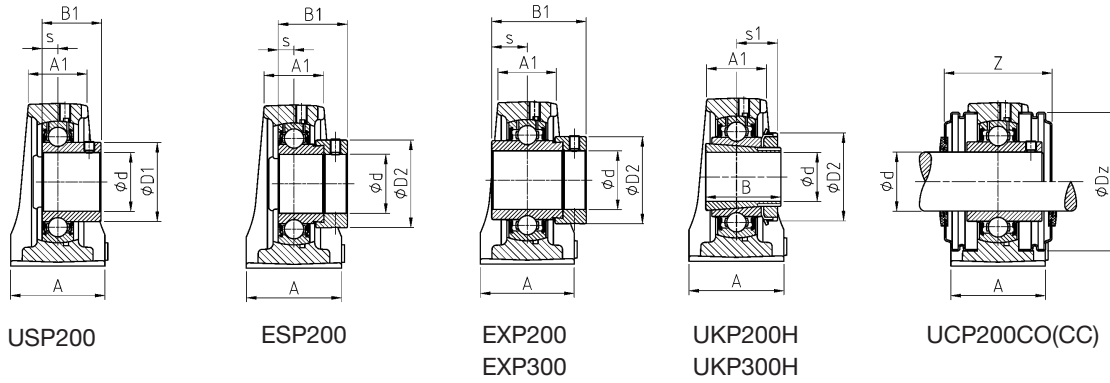

USP200

ESP200

EXP200
EXP300UKP200H
UKP300H

UCP200CO(CC)

D1	D2	G	Z	Dz	Gehäuse	Einsatz	Schutzkappen offen *	Schutzkappen geschlossen **	Tragzahl dyn.	Tragzahl stat.	Gewicht	Wellendurch- messer
D1	D2	G	Z	Dz					C _r [kN]	C _{or} [kN]	[kg]	d [mm]
69,0	-	M6x1	77,0	110,0	P211	UC211	CO	CC	43,55	29,20	3,7	55
69,0	-	M6x1	77,0	110,0	P211	US211	CO	CC	43,55	29,20	3,6	
-	76,2	M6x1	***	***	P211	ES211	***	***	43,55	29,20	3,4	
-	76,2	M6x1	***	***	P211	EX211	***	***	43,55	29,20	3,9	
-	80,0	M6x1	89,0	120,0	P212	UK212 + H2312	CO	CC	52,50	32,80	5,0	
74,9	-	M6x1	-	-	P311	UC311	-	-	71,50	44,80	7,6	60
-	83,0	M6x1	-	-	P311	EX311	-	-	71,50	44,80	8,0	
-	80,0	M6x1	-	-	P312	UK312 + H2312	-	-	81,60	51,80	9,5	
74,9	-	M6x1	89,0	120,0	P212	UC212	CO	CC	52,50	32,80	5,0	
74,9	-	M6x1	89,0	120,0	P212	US212	CO	CC	52,50	32,80	4,8	
-	84,2	M6x1	***	***	P212	ES212	***	***	52,50	32,80	4,7	65
-	84,2	M6x1	***	***	P212	EX212	***	***	52,50	32,80	5,4	
-	85,0	M6x1	89,0	132,0	P213	UK213 + H2313	CO	CC	57,20	40,00	6,1	
81,0	-	M6x1	-	-	P312	UC312	-	-	81,60	51,80	9,5	
-	89,0	M6x1	-	-	P312	EX312	-	-	81,60	51,80	9,8	
-	85,0	M6x1	-	-	P313	UK313 + H2313	-	-	93,86	60,50	11,2	70
82,0	-	M6x1	89,0	132,0	P213	UC213	CO	CC	57,20	40,00	6,1	
-	86,0	M6x1	***	***	P213	EX213	***	***	57,20	40,00	6,6	
-	98,0	M10x1	-	-	P215	UK215 + H2315	-	-	66,00	49,50	6,9	
87,5	-	M6x1	-	-	P313	UC313	-	-	93,86	60,50	11,2	
-	97,0	M6x1	-	-	P313	EX313	-	-	93,86	60,50	11,6	75
-	98,0	M10x1	-	-	P315	UK315 + H2315	-	-	113,36	76,80	15,9	
86,5	-	M10x1	-	-	P214	UC214	-	-	62,00	45,00	6,6	
-	96,8	M10x1	-	-	P214	EX214	-	-	62,00	45,00	7,1	
-	105,0	M10x1	-	-	P216	UK216 + H2316	-	-	72,50	54,20	9,4	
94,0	-	M10x1	-	-	P314	UC314	-	-	104,26	68,00	13,1	75
-	102,0	M10x1	-	-	P314	EX314	-	-	104,26	68,00	13,6	
-	105,0	M10x1	-	-	P316	UK316 + H2316	-	-	122,85	86,50	19,2	
91,5	-	M10x1	-	-	P215	UC215	-	-	66,00	49,50	7,3	
-	102,0	M10x1	-	-	P215	EX215	-	-	66,00	49,50	8,0	
-	110,0	M10x1	-	-	P217	UK217 + H2317	-	-	83,20	63,80	11,3	75
100,5	-	M10x1	-	-	P315	UC315	-	-	113,36	76,80	15,2	
-	113,0	M10x1	-	-	P315	EX315	-	-	113,36	76,80	16,2	
-	110,0	M10x1	-	-	P317	UK317 + H2317	-	-	132,60	96,50	21,4	

* = mit zwei offenen Schutzkappen für durchgehende Wellen: Nachsetzzeichen CO wie Bestellbeispiel Seite 6

** = mit einer offenen und einer geschlossenen Schutzkappe für Wellenenden: Nachsetzzeichen CC wie Bestellbeispiel Seite 6

*** = mit Schutzkappen für Einsätze mit Excenterring auf Anfrage lieferbar

Gehäuse P200 nachschmierbar
P300 nachschmierbar

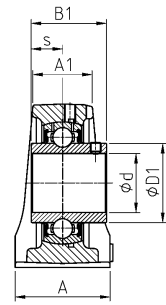
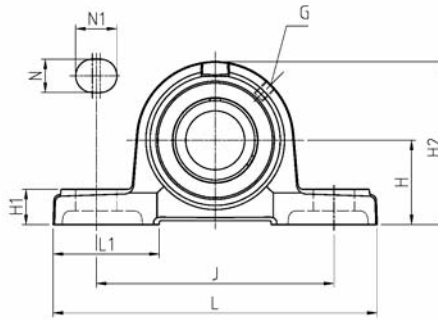
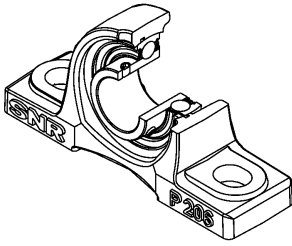

UCP200
UCP300

Wellendurchmesser
Einheit

Hauptabmessungen in mm

d [mm]		L	H	A1	A	J	N	N1	L1	H1	H2	s1	B	B1	s
80	UCP216	292	88,9	51	78	232	25	31	91	30	175	-	-	82,6	33,3
	EXP216	292	88,9	51	78	232	25	31	91	30	175	-	-	95,2	37,3
	UKP218H	327	101,6	55	88	262	27	33	100	34	200	42,0	86,0	-	-
	UCP316	400	106,0	66	110	300	27	40	110	40	210	-	-	86,0	34,0
	EXP316	400	106,0	66	110	300	27	40	110	40	210	-	-	106,4	40,5
	UKP318H	430	118,0	72	110	330	33	45	120	45	235	48,0	86,0	-	-
85	UCP217	310	95,2	53	83	247	25	31	96	32	187	-	-	85,7	34,1
	EXP217	310	95,2	53	83	247	25	31	96	32	187	-	-	73,2	23,4
	UCP317	420	112,0	69	110	320	33	45	120	40	220	-	-	96,0	40,0
	EXP317	420	112,0	69	110	320	33	45	120	40	220	-	-	109,5	42,0
	UKP319H	470	125,0	75	120	360	36	50	125	45	250	52,0	90,0	-	-
90	UCP218	327	101,6	55	88	262	27	33	100	34	200	-	-	96,0	39,7
	EXP218	327	101,6	55	88	262	27	33	100	34	200	-	-	72,5	24,5
	UCP318	430	118,0	72	110	330	33	45	120	45	235	-	-	96,0	40,0
	EXP318	430	118,0	72	110	330	33	45	120	45	235	-	-	115,9	43,6
	UKP320H	490	140,0	81	120	380	36	50	130	50	275	54,0	97,0	-	-
95	UCP319	470	125,0	75	120	360	36	50	125	45	250	-	-	103,0	41,0
	EXP319	470	125,0	75	120	360	36	50	125	45	250	-	-	122,3	46,8
100	UCP320	490	140,0	81	120	380	36	50	130	50	275	-	-	108,0	42,0
	EXP320	490	140,0	81	120	380	36	50	130	50	275	-	-	128,6	50,0
	UKP322H	520	150,0	83	140	400	40	55	135	55	300	61,0	105,0	-	-
105	UCP321	490	140,0	80	120	380	36	50	130	50	280	-	-	112,0	44,0
110	UCP322	520	150,0	83	140	400	40	55	135	55	300	-	-	117,0	46,0
	UKP324H	570	160,0	88	140	450	40	55	140	65	320	65,0	112,0	-	-
115	UKP326H	600	180,0	94	140	480	40	55	140	75	355	69,0	121,0	-	-
120	UCP324	570	160,0	88	140	450	40	55	140	65	320	-	-	126,0	51,0
125	UKP328H	620	200,0	92	140	500	40	55	140	75	390	73,0	131,0	-	-
130	UCP326	600	180,0	94	140	480	40	55	140	75	355	-	-	135,0	54,0
140	UCP328	620	200,0	92	140	500	40	55	140	75	390	-	-	145,0	59,0

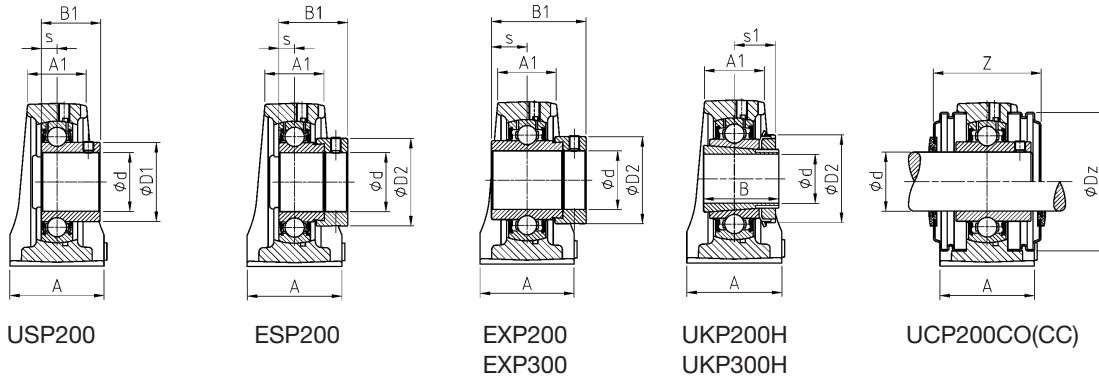

D1	D2	G	Z	Dz	Gehäuse	Einsatz	Schutzkappen offen *	Schutzkappen geschlossen **	Tragzahl dyn.	Tragzahl stat.	Gewicht	Wellendurch- messer		
													C_r [kN]	C_{or} [kN]
98,0	-	M10x1	-	-	P216	UC216	-	-	72,50	54,20	8,9	80		
-	110,0	M10x1	-	-	P216	EX216	-	-	72,50	54,20	9,3			
-	120,0	M10x1	-	-	P218	UK218 + H2318	-	-	96,00	71,50	13,7			
107,9	-	M10x1	-	-	P316	UC316	-	-	122,85	86,50	19,0			
-	119,0	M10x1	-	-	P316	EX316	-	-	122,85	86,50	20,1			
-	120,0	M10x1	-	-	P318	UK318 + H2318	-	-	143,00	108,00	25,2			
105,1	-	M10x1	-	-	P217	UC217	-	-	83,20	63,80	10,8	85		
-	119,0	M10x1	-	-	P217	EX217	-	-	83,20	63,80	11,2			
114,0	-	M10x1	-	-	P317	UC317	-	-	132,60	96,50	21,4			
-	127,0	M10x1	-	-	P317	EX317	-	-	132,60	96,50	22,5			
-	125,0	M10x1	-	-	P319	UK319 + H2319	-	-	156,00	122,00	30,8			
111,0	-	M10x1	-	-	P218	UC218	-	-	96,00	71,50	13,5	90		
-	120,0	M10x1	-	-	P218	EX218	-	-	96,00	71,50	13,9			
120,0	-	M10x1	-	-	P318	UC318	-	-	143,00	108,00	25,1			
-	133,0	M10x1	-	-	P318	EX318	-	-	143,00	108,00	26,3			
-	130,0	M10x1	-	-	P320	UK320 + H2320	-	-	171,60	140,00	37,8			
126,5	-	M10x1	-	-	P319	UC319	-	-	156,00	122,00	30,5	95		
-	140,0	M10x1	-	-	P319	EX319	-	-	156,00	122,00	32,0			
134,5	-	M10x1	-	-	P320	UC320	-	-	171,60	140,00	38,1	100		
-	146,0	M10x1	-	-	P320	EX320	-	-	171,60	140,00	39,9			
-	145,0	M10x1	-	-	P322	UK322 + H2322	-	-	205,00	178,00	51,3			
140,5	-	M10x1	-	-	P321	UC321	-	-	182,00	155,00	38,5	105		
149,0	-	M10x1	-	-	P322	UC322	-	-	205,00	178,00	47,9	110		
-	155,0	M10x1	-	-	P324	UK324 + H2324	-	-	228,00	208,00	61,5			
-	165,0	M10x1	-	-	P326	UK326 + H2326	-	-	252,00	242,00	79,9			
163,0	-	M10x1	-	-	P324	UC324	-	-	228,00	208,00	58,8	120		
-	180,0	M10x1	-	-	P328	UK328 + H2328	-	-	275,00	272,00	96,3	125		
177,0	-	M10x1	-	-	P326	UC326	-	-	252,00	242,00	75,0	130		
190,0	-	M10x1	-	-	P328	UC328	-	-	275,00	272,00	90,4	140		

* = mit zwei offenen Schutzkappen für durchgehende Wellen: Nachsetzzeichen CO wie Bestellbeispiel Seite 6

** = mit einer offenen und einer geschlossenen Schutzkappe für Wellenenden: Nachsetzzeichen CC wie Bestellbeispiel Seite 6

*** = mit Schutzkappen für Einsätze mit Excenterring auf Anfrage lieferbar

Gehäuse PH200 nachschmierbar

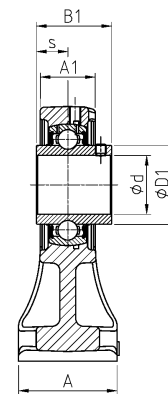
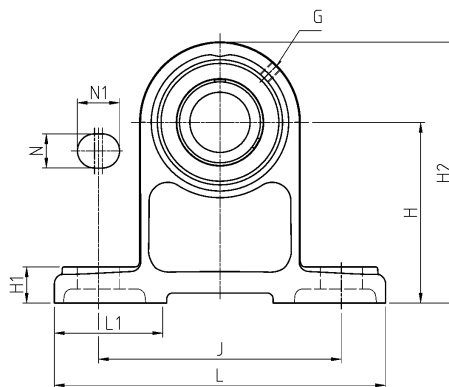
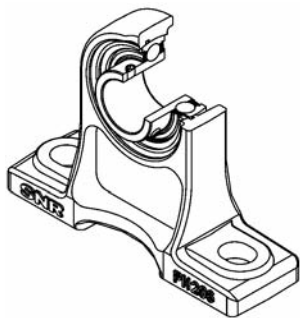

UCPH200

Wellendurchmesser
Einheit

Hauptabmessungen in mm

d [mm]		L	H	A1	A	J	N	N1	L1	H1	H2	s1	B	B1	s
12	UCPH201	127	70	22	40	95	13	19	48	15	101	-	-	31,0	12,7
	USPH201	127	70	19	38	95	12	16	48	13	97	-	-	22,0	6,0
	ESPH201	127	70	19	38	95	12	16	48	13	97	-	-	28,6	6,5
	EXPH201	127	70	22	40	95	13	19	48	15	101	-	-	43,5	17,0
15	UCPH202	127	70	22	40	95	13	19	48	15	101	-	-	31,0	12,7
	USPH202	127	70	19	38	95	12	16	48	13	97	-	-	22,0	6,0
	ESPH202	127	70	19	38	95	12	16	48	13	97	-	-	28,6	6,5
	EXPH202	127	70	22	40	95	13	19	48	15	101	-	-	43,5	17,0
17	UCPH203	127	70	22	40	95	13	19	48	15	101	-	-	31,0	12,7
	USPH203	127	70	19	38	95	12	16	48	13	97	-	-	22,0	6,0
	ESPH203	127	70	19	38	95	12	16	48	13	97	-	-	28,6	6,5
	EXPH203	127	70	22	40	95	13	19	48	15	101	-	-	43,5	17,0
20	UCPH204	127	70	22	40	95	13	19	48	15	101	-	-	31,0	12,7
	USPH204	127	70	22	40	95	13	19	48	15	101	-	-	25,0	7,0
	ESPH204	127	70	22	40	95	13	19	48	15	101	-	-	30,9	7,5
	EXPH204	127	70	22	40	95	13	19	48	15	101	-	-	43,5	17,0
	UKPH205H	140	80	24	50	105	13	19	50	16	114	18,5	35,0	-	-
25	UCPH205	140	80	24	50	105	13	19	50	16	114	-	-	34,0	14,3
	USPH205	140	80	24	50	105	13	19	50	16	114	-	-	27,0	7,5
	ESPH205	140	80	24	50	105	13	19	50	16	114	-	-	30,9	7,5
	EXPH205	140	80	24	50	105	13	19	50	16	114	-	-	44,3	17,4
	UKPH206H	165	90	28	50	121	17	21	56	18	130	20,5	38,0	-	-
30	UCPH206	165	90	28	50	121	17	21	56	18	130	-	-	38,1	15,9
	USPH206	165	90	28	50	121	17	21	56	18	130	-	-	30,0	8,0
	ESPH206	165	90	28	50	121	17	21	56	18	130	-	-	35,7	9,0
	EXPH206	165	90	28	50	121	17	21	56	18	130	-	-	48,3	18,2
	UKPH207H	167	95	30	60	127	17	21	56	19	140	22,5	43,0	-	-
35	UCPH207	167	95	30	60	127	17	21	56	19	140	-	-	42,9	17,5
	USPH207	167	95	30	60	127	17	21	56	19	140	-	-	32,0	8,5
	ESPH207	167	95	30	60	127	17	21	56	19	140	-	-	38,9	9,5
	EXPH207	167	95	30	60	127	17	21	56	19	140	-	-	51,1	18,8
	UKPH208H	184	100	34	70	137	17	25	58	19	149	24,5	46,0	-	-

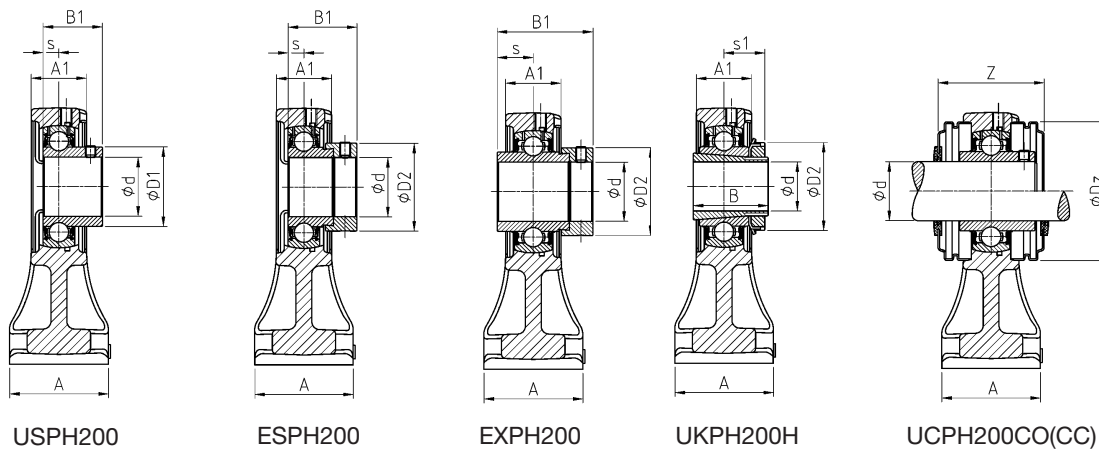

USP200

ESPH200

EXPH200

UKPH200H

UCPH200CO(CC)

D1	D2	G	Z	Dz	Gehäuse	Einsatz	Schutzkappen offen *	Schutzkappen geschlossen **	Tragzahl dyn.	Tragzahl stat.	Gewicht	Wellendurch- messer
D1	D2	G	Z	Dz					C _r [kN]	C _{or} [kN]	[kg]	d [mm]
29,0	-	M6x1	44,6	54,0	PH204	UC201	CO	CC	12,80	6,65	0,9	12
24,6	-	M6x1	40,6	46,0	PH203	US201	CO	CC	9,55	4,78	0,7	
-	28,6	M6x1	***	***	PH203	ES201	***	***	9,55	4,78	0,7	
-	33,3	M6x1	***	***	PH204	EX201	***	***	12,80	6,65	1,0	
29,0	-	M6x1	44,6	54,0	PH204	UC202	CO	CC	12,80	6,65	0,9	15
24,6	-	M6x1	40,6	46,0	PH203	US202	CO	CC	9,55	4,78	0,7	
-	28,6	M6x1	***	***	PH203	ES202	***	***	9,55	4,78	0,7	
-	33,3	M6x1	***	***	PH204	EX202	***	***	12,80	6,65	1,0	
29,0	-	M6x1	44,6	54,0	PH204	UC203	CO	CC	12,80	6,65	0,8	17
24,6	-	M6x1	40,6	46,0	PH203	US203	CO	CC	9,55	4,78	0,7	
-	28,6	M6x1	***	***	PH203	ES203	***	***	9,55	4,78	0,7	
-	33,3	M6x1	***	***	PH204	EX203	***	***	12,80	6,65	1,0	
29,0	-	M6x1	44,6	54,0	PH204	UC204	CO	CC	12,80	6,65	0,9	20
29,0	-	M6x1	44,6	54,0	PH204	US204	CO	CC	12,80	6,65	0,8	
-	33,3	M6x1	***	***	PH204	ES204	***	***	12,80	6,65	0,9	
-	33,3	M6x1	***	***	PH204	EX204	***	***	12,80	6,65	0,9	
-	38,0	M6x1	47,8	60,0	PH205	UK205 + H2305	CO	CC	14,00	7,88	1,2	
34,0	-	M6x1	47,8	60,0	PH205	UC205	CO	CC	14,00	7,88	1,2	25
34,0	-	M6x1	47,8	60,0	PH205	US205	CO	CC	14,00	7,88	1,2	
-	38,1	M6x1	***	***	PH205	ES205	***	***	14,00	7,88	1,2	
-	38,1	M6x1	***	***	PH205	EX205	***	***	14,00	7,88	1,2	
-	45,0	M6x1	52,8	70,0	PH206	UK206 + H2306	CO	CC	19,50	11,20	1,8	
40,3	-	M6x1	52,8	70,0	PH206	UC206	CO	CC	19,50	11,20	1,7	30
40,3	-	M6x1	52,8	70,0	PH206	US206	CO	CC	19,50	11,20	1,7	
-	44,5	M6x1	***	***	PH206	ES206	***	***	19,50	11,20	1,7	
-	44,5	M6x1	***	***	PH206	EX206	***	***	19,50	11,20	1,8	
-	52,0	M6x1	57,4	80,0	PH207	UK207 + H2307	CO	CC	25,70	15,20	2,3	
48,0	-	M6x1	57,4	80,0	PH207	UC207	CO	CC	25,70	15,20	2,2	35
48,0	-	M6x1	57,4	80,0	PH207	US207	CO	CC	25,70	15,20	2,2	
-	55,6	M6x1	***	***	PH207	ES207	***	***	25,70	15,20	2,3	
-	55,6	M6x1	***	***	PH207	EX207	***	***	25,70	15,20	2,4	
-	58,0	M6x1	66,8	88,0	PH208	UK208 + H2308	CO	CC	29,60	18,20	2,9	

* = mit zwei offenen Schutzkappen für durchgehende Wellen: Nachsetzzeichen CO wie Bestellbeispiel Seite 6

** = mit einer offenen und einer geschlossenen Schutzkappe für Wellenenden: Nachsetzzeichen CC wie Bestellbeispiel Seite 6

*** = mit Schutzkappen für Einsätze mit Excentring auf Anfrage lieferbar

Gehäuse PH200 nachschmierbar

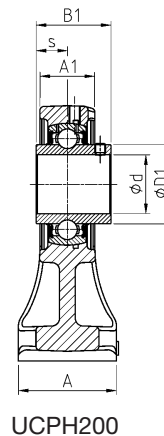
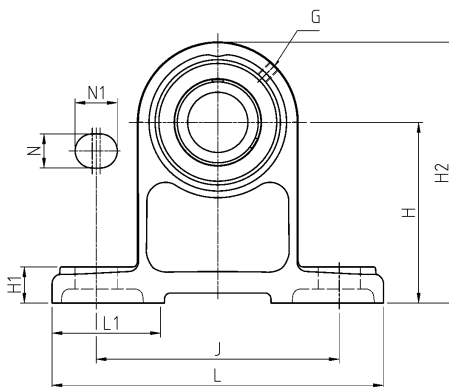
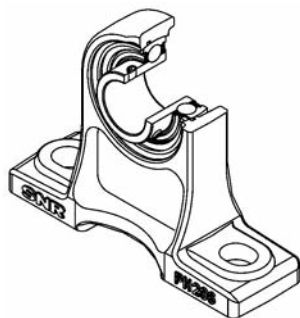

Wellendurchmesser		Einheit		Hauptabmessungen in mm												
d [mm]		L	H	A1	A	J	N	N1	L1	H1	H2	s1	B	B1	s	
40	UCPH208	184	100	34	70	137	17	25	58	19	149	-	-	49,2	19,0	
	USPH208	184	100	34	70	137	17	25	58	19	149	-	-	34,0	9,0	
	ESPH208	184	100	34	70	137	17	25	58	19	149	-	-	43,7	11,0	
	EXPH208	184	100	34	70	137	17	25	58	19	149	-	-	56,3	21,4	
	UKPH209H	190	105	36	70	146	17	25	62	20	157	26,0	50,0	-	-	
45	UCPH209	190	105	36	70	146	17	25	62	20	157	-	-	49,2	19,0	
	USPH209	190	105	36	70	146	17	25	62	20	157	-	-	41,2	10,2	
	ESPH209	190	105	36	70	146	17	25	62	20	157	-	-	43,7	11,0	
	EXPH209	190	105	36	70	146	17	25	62	20	157	-	-	56,3	21,4	
	UKPH210H	206	110	36	70	159	20	25	65	22	165	27,5	55,0	-	-	
50	UCPH210	206	110	36	70	159	20	25	65	22	165	-	-	51,6	19,0	
	USPH210	206	110	36	70	159	20	25	65	22	165	-	-	43,5	10,9	
	ESPH210	206	110	36	70	159	20	25	65	22	165	-	-	43,7	11,0	
	EXPH210	206	110	36	70	159	20	25	65	22	165	-	-	62,7	24,6	

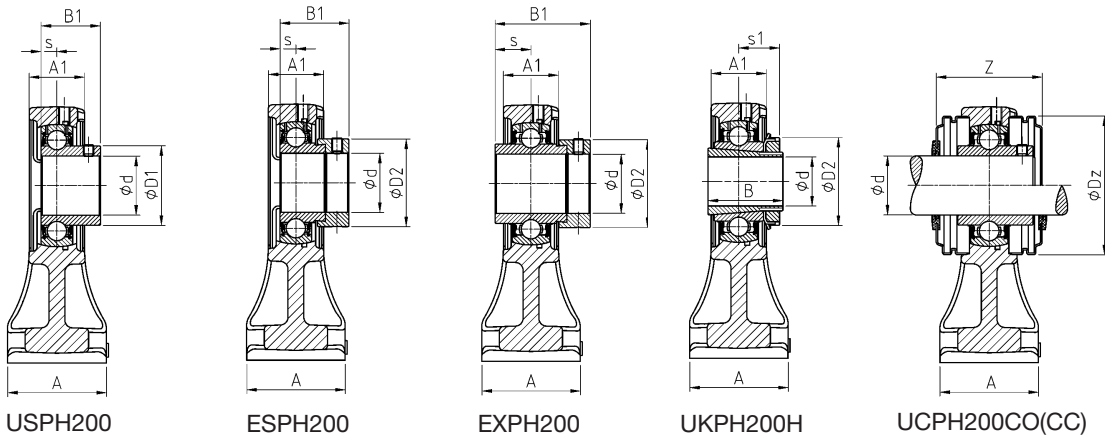

D1	D2	G	Z	Dz	Gehäuse	Einsatz	Schutzkappen offen *	Schutzkappen geschlossen **	Tragzahl dyn.	Tragzahl stat.	Gewicht	Wellendurch- messer
D1	D2	G	Z	Dz					C _r [kN]	C _{or} [kN]	[kg]	d [mm]
53,0	-	M6x1	66,8	88,0	PH208	UC208	CO	CC	29,60	18,20	2,8	40
53,0	-	M6x1	66,8	88,0	PH208	US208	CO	CC	29,60	18,20	2,8	40
-	60,3	M6x1	***	***	PH208	ES208	***	***	29,60	18,20	2,8	40
-	60,3	M6x1	***	***	PH208	EX208	***	***	29,60	18,20	3,0	40
-	65,0	M6x1	67,8	95,0	PH209	UK209 + H2309	CO	CC	31,85	20,80	3,3	45
57,2	-	M6x1	67,8	95,0	PH209	UC209	CO	CC	31,85	20,80	3,1	45
57,2	-	M6x1	67,8	95,0	PH209	US209	CO	CC	31,85	20,80	3,1	45
-	63,5	M6x1	***	***	PH209	ES209	***	***	31,85	20,80	3,1	45
-	63,5	M6x1	***	***	PH209	EX209	***	***	31,85	20,80	3,3	45
-	70,0	M6x1	74,6	100,0	PH210	UK210 + H2310	CO	CC	35,10	23,20	3,8	50
61,8	-	M6x1	74,6	100,0	PH210	UC210	CO	CC	35,10	23,20	3,6	50
61,8	-	M6x1	74,6	100,0	PH210	US210	CO	CC	35,10	23,20	3,6	50
-	69,9	M6x1	***	***	PH210	ES210	***	***	35,10	23,20	3,6	50
-	69,9	M6x1	***	***	PH210	EX210	***	***	35,10	23,20	3,8	50

* = mit zwei offenen Schutzkappen für durchgehende Wellen: Nachsetzzeichen CO wie Bestellbeispiel Seite 6

** = mit einer offenen und einer geschlossenen Schutzkappe für Wellenenden: Nachsetzzeichen CC wie Bestellbeispiel Seite 6

*** = mit Schutzkappen für Einsätze mit Excenterring auf Anfrage lieferbar

Gehäuse PAE200 nachschmierbar

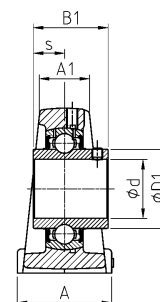
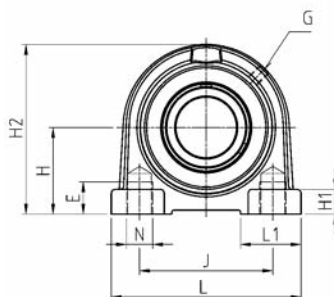
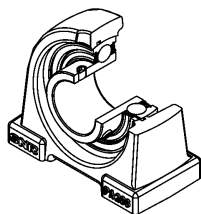

UCPAE200

Wellendurchmesser		Einheit		Hauptabmessungen in mm												
d [mm]		L	L1	H	H1	A1	A	J	N	E	H2	s1	B	B1	s	
12	UCPAE201	65	18,0	33,3	9	19	32	50,8	M8	10,0	64	-	-	31,0	12,7	
	USPAE201	63	17,5	30,2	9	18	30	47,0	M8	10,0	57	-	-	22,0	6,0	
	ESPAE201	63	17,5	30,2	9	18	30	47,0	M8	10,0	57	-	-	28,6	6,5	
	EXPAE201	65	18,0	33,3	9	19	32	50,8	M8	10,0	64	-	-	43,5	17,0	
15	UCPAE202	65	18,0	33,3	9	19	32	50,8	M8	10,0	64	-	-	31,0	12,7	
	USPAE202	63	17,5	30,2	9	18	30	47,0	M8	10,0	57	-	-	22,0	6,0	
	ESPAE202	63	17,5	30,2	9	18	30	47,0	M8	10,0	57	-	-	28,6	6,5	
	EXPAE202	65	18,0	33,3	9	19	32	50,8	M8	10,0	64	-	-	43,5	17,0	
17	UCPAE203	65	18,0	33,3	9	19	32	50,8	M8	10,0	64	-	-	31,0	12,7	
	USPAE203	63	17,5	30,2	9	18	30	47,0	M8	10,0	57	-	-	22,0	6,0	
	ESPAE203	63	17,5	30,2	9	18	30	47,0	M8	10,0	57	-	-	28,6	6,5	
	EXPAE203	65	18,0	33,3	9	19	32	50,8	M8	10,0	64	-	-	43,5	17,0	
20	UCPAE204	65	18,0	33,3	9	19	32	50,8	M8	10,0	64	-	-	31,0	12,7	
	USPAE204	65	18,0	33,3	9	19	32	50,8	M8	10,0	64	-	-	25,0	7,0	
	ESPAE204	65	18,0	33,3	9	19	32	50,8	M8	10,0	64	-	-	30,9	7,5	
	EXPAE204	65	18,0	33,3	9	19	32	50,8	M8	10,0	64	-	-	43,5	17,0	
	UKPAE205H	70	21,0	36,5	10	21	36	50,8	M10	12,5	70	18,5	35,0	-	-	
25	UCPAE205	70	21,0	36,5	10	21	36	50,8	M10	12,5	70	-	-	34,0	14,3	
	USPAE205	70	21,0	36,5	10	21	36	50,8	M10	12,5	70	-	-	27,0	7,5	
	ESPAE205	70	21,0	36,5	10	21	36	50,8	M10	12,5	70	-	-	30,9	7,5	
	EXPAE205	70	21,0	36,5	10	21	36	50,8	M10	12,5	70	-	-	44,3	17,4	
	UKPAE206H	98	22,0	42,9	11	25	38	76,2	M10	12,5	82	20,5	38,0	-	-	
30	UCPAE206	98	22,0	42,9	11	25	38	76,2	M10	12,5	82	-	-	38,1	15,9	
	USPAE206	98	22,0	42,9	11	25	38	76,2	M10	12,5	82	-	-	30,0	8,0	
	ESPAE206	98	22,0	42,9	11	25	38	76,2	M10	12,5	82	-	-	35,7	9,0	
	EXPAE206	98	22,0	42,9	11	25	38	76,2	M10	12,5	82	-	-	48,3	18,2	
	UKPAE207H	103	22,5	47,6	12	27	45	82,6	M10	12,5	93	22,5	43,0	-	-	
35	UCPAE207	103	22,5	47,6	12	27	45	82,6	M10	12,5	93	-	-	42,9	17,5	
	USPAE207	103	22,5	47,6	12	27	45	82,6	M10	12,5	93	-	-	32,0	8,5	
	ESPAE207	103	22,5	47,6	12	27	45	82,6	M10	12,5	93	-	-	38,9	9,5	
	EXPAE207	103	22,5	47,6	12	27	45	82,6	M10	12,5	93	-	-	51,1	18,8	
	UKPAE208H	116	27,0	49,2	13	30	47	88,9	M12	15,0	99	24,5	46,0	-	-	
40	UCPAE208	116	27,0	49,2	13	30	47	88,9	M12	15,0	99	-	-	49,2	19,0	
	USPAE208	116	27,0	49,2	13	30	47	88,9	M12	15,0	99	-	-	34,0	9,0	
	ESPAE208	116	27,0	49,2	13	30	47	88,9	M12	15,0	99	-	-	43,7	11,0	
	EXPAE208	116	27,0	49,2	13	30	47	88,9	M12	15,0	99	-	-	56,3	21,4	
	UKPAE209H	120	29,0	53,9	14	32	48	95,3	M12	15,0	107	26,0	50,0	-	-	

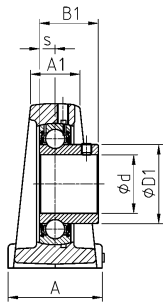

USPAE200

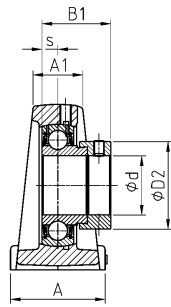

ESPAE200

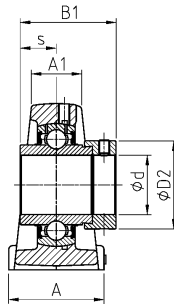

EXPAE200

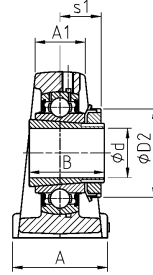

UKPAE200H

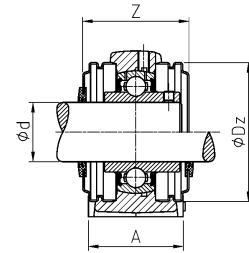

UCPAE200CO(CC)

					Gehäuse	Einsatz	Schutzkappen offen *		Schutzkappen geschlossen **	Tragzahl dyn.	Tragzahl stat.	Gewicht	Wellendurch- messer
D1	D2	G	Z	Dz						C _r [kN]	C _{or} [kN]	[kg]	d [mm]
29,0	-	R1/8"	44,6	54,0	PAE204	UC201	CO	CC		12,80	6,65	0,5	12
24,6	-	M6x1	40,6	46,0	PAE203	US201	CO	CC		9,55	4,78	0,3	
-	28,6	M6x1	***	***	PAE203	ES201	***	***		9,55	4,78	0,4	
-	33,3	R1/8"	***	***	PAE204	EX201	***	***		12,80	6,65	0,6	
29,0	-	R1/8"	44,6	54,0	PAE204	UC202	CO	CC		12,80	6,65	0,5	15
24,6	-	M6x1	40,6	46,0	PAE203	US202	CO	CC		9,55	4,78	0,3	
-	28,6	M6x1	***	***	PAE203	ES202	***	***		9,55	4,78	0,4	
-	33,3	R1/8"	***	***	PAE204	EX202	***	***		12,80	6,65	0,6	
29,0	-	R1/8"	44,6	54,0	PAE204	UC203	CO	CC		12,80	6,65	0,4	17
24,6	-	M6x1	40,6	46,0	PAE203	US203	CO	CC		9,55	4,78	0,4	
-	28,6	M6x1	***	***	PAE203	ES203	***	***		9,55	4,78	0,4	
-	33,3	R1/8"	***	***	PAE204	EX203	***	***		12,80	6,65	0,5	
29,0	-	R1/8"	44,6	54,0	PAE204	UC204	CO	CC		12,80	6,65	0,5	20
29,0	-	R1/8"	44,6	54,0	PAE204	US204	CO	CC		12,80	6,65	0,4	
-	33,3	R1/8"	***	***	PAE204	ES204	***	***		12,80	6,65	0,4	
-	33,3	R1/8"	***	***	PAE204	EX204	***	***		12,80	6,65	0,5	
-	38,0	R1/8"	47,8	60,0	PAE205	UK205 + H2305	CO	CC		14,00	7,88	0,6	
34,0	-	R1/8"	47,8	60,0	PAE205	UC205	CO	CC		14,00	7,88	0,6	25
34,0	-	R1/8"	47,8	60,0	PAE205	US205	CO	CC		14,00	7,88	0,6	
-	38,1	R1/8"	***	***	PAE205	ES205	***	***		14,00	7,88	0,6	
-	38,1	R1/8"	***	***	PAE205	EX205	***	***		14,00	7,88	0,6	
-	45,0	R1/8"	52,8	70,0	PAE206	UK206 + H2306	CO	CC		19,50	11,20	1,0	
40,3	-	R1/8"	52,8	70,0	PAE206	UC206	CO	CC		19,50	11,20	1,0	30
40,3	-	R1/8"	52,8	70,0	PAE206	US206	CO	CC		19,50	11,20	0,9	
-	44,5	R1/8"	***	***	PAE206	ES206	***	***		19,50	11,20	1,0	
-	44,5	R1/8"	***	***	PAE206	EX206	***	***		19,50	11,20	1,1	
-	52,0	R1/8"	57,4	80,0	PAE207	UK207 + H2307	CO	CC		25,70	15,20	1,4	
48,0	-	R1/8"	57,4	80,0	PAE207	UC207	CO	CC		25,70	15,20	1,3	35
48,0	-	R1/8"	57,4	80,0	PAE207	US207	CO	CC		25,70	15,20	1,3	
-	55,6	R1/8"	***	***	PAE207	ES207	***	***		25,70	15,20	1,3	
-	55,6	R1/8"	***	***	PAE207	EX207	***	***		25,70	15,20	1,4	
-	58,0	R1/8"	66,8	88,0	PAE208	UK208 + H2308	CO	CC		29,60	18,20	1,7	
53,0	-	R1/8"	66,8	88,0	PAE208	UC208	CO	CC		29,60	18,20	1,6	40
53,0	-	R1/8"	66,8	88,0	PAE208	US208	CO	CC		29,60	18,20	1,6	
-	60,3	R1/8"	***	***	PAE208	ES208	***	***		29,60	18,20	1,6	
-	60,3	R1/8"	***	***	PAE208	EX208	***	***		29,60	18,20	1,8	
-	65,0	R1/8"	67,8	95,0	PAE209	UK209 + H2309	CO	CC		31,85	20,80	2,0	

* = mit zwei offenen Schutzkappen für durchgehende Wellen: Nachsetzzeichen CO wie Bestellbeispiel Seite 6

** = mit einer offenen und einer geschlossenen Schutzkappe für Wellenenden: Nachsetzzeichen CC wie Bestellbeispiel Seite 6

*** = mit Schutzkappen für Einsätze mit Excenterring auf Anfrage lieferbar



Gehäuse PAE200 nachschmierbar

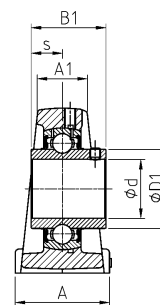
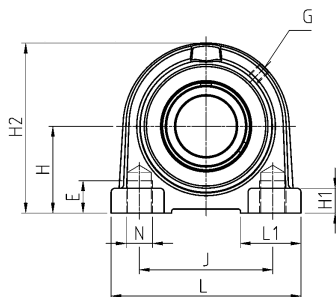
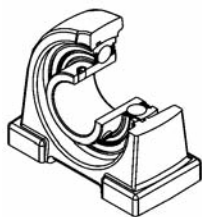

UCPAE200

Wellendurchmesser
Einheit

Hauptabmessungen in mm

d [mm]		L	L1	H	H1	A1	A	J	N	E	H2	s1	B	B1	s
45	UCPAE209	120	29,0	53,9	14	32	48	95,3	M12	15,0	107	-	-	49,2	19,0
	USPAE209	120	29,0	53,9	14	32	48	95,3	M12	15,0	107	-	-	41,2	10,2
	ESPAE209	120	29,0	53,9	14	32	48	95,3	M12	15,0	107	-	-	43,7	11,0
	EXPAE209	120	29,0	53,9	14	32	48	95,3	M12	15,0	107	-	-	56,3	21,4
	UKPAE210H	135	33,5	57,2	15	34	54	101,6	M16	20,0	115	27,5	55,0	-	-
50	UCPAE210	135	33,5	57,2	15	34	54	101,6	M16	20,0	115	-	-	51,6	19,0
	USPAE210	135	33,5	57,2	15	34	54	101,6	M16	20,0	115	-	-	43,5	10,9
	ESPAE210	135	33,5	57,2	15	34	54	101,6	M16	20,0	115	-	-	43,7	11,0
	EXPAE210	135	33,5	57,2	15	34	54	101,6	M16	20,0	115	-	-	62,7	24,6
	UKPAE211H	150	32,0	64,0	16	35	60	118,0	M16	20,0	125	29,0	59,0	-	-
55	UCPAE211	150	32,0	64,0	16	35	60	118,0	M16	20,0	125	-	-	55,6	22,2
	USPAE211	150	32,0	64,0	16	35	60	118,0	M16	20,0	125	-	-	45,3	11,8
	ESPAE211	150	32,0	64,0	16	35	60	118,0	M16	20,0	125	-	-	48,4	12,0
	EXPAE211	150	32,0	64,0	16	35	60	118,0	M16	20,0	125	-	-	71,3	27,7
	UKPAE212H	150	32,0	69,9	16	42	60	118,0	M16	20,0	140	31,0	62,0	-	-
60	UCPAE212	150	32,0	69,9	16	42	60	118,0	M16	20,0	140	-	-	65,1	25,4
	USPAE212	150	32,0	69,9	16	42	60	118,0	M16	20,0	140	-	-	53,7	14,9
	ESPAE212	150	32,0	69,9	16	42	60	118,0	M16	20,0	140	-	-	49,3	12,0
	EXPAE212	150	32,0	69,9	16	42	60	118,0	M16	20,0	140	-	-	77,7	30,9

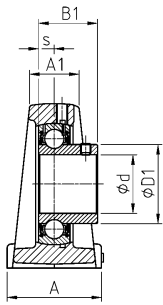

USPAE200

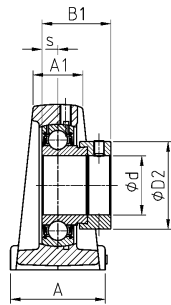

ESPAE200

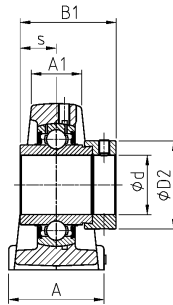

EXPAE200

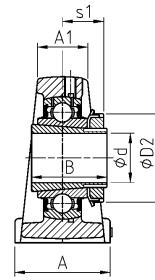

UKPAE200H

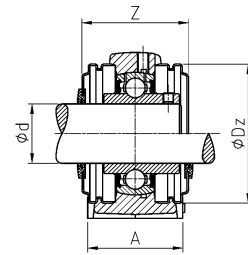

UCPAE200CO(CC)

					Gehäuse	Einsatz	Schutzkappen offen *	Schutzkappen geschlossen **	Tragzahl dyn.	Tragzahl stat.	Gewicht	Wellendurch- messer
D1	D2	G	Z	Dz					C _r [kN]	C _{or} [kN]	[kg]	d [mm]
57,2	-	R1/8"	67,8	95,0	PAE209	UC209	CO	CC	31,85	20,80	1,9	45
57,2	-	R1/8"	67,8	95,0	PAE209	US209	CO	CC	31,85	20,80	1,9	
-	63,5	R1/8"	***	***	PAE209	ES209	***	***	31,85	20,80	1,9	
-	63,5	R1/8"	***	***	PAE209	EX209	***	***	31,85	20,80	2,1	
-	70,0	R1/8"	74,6	100,0	PAE210	UK210 + H2310	CO	CC	35,10	23,20	2,6	50
61,8	-	R1/8"	74,6	100,0	PAE210	UC210	CO	CC	35,10	23,20	2,5	
61,8	-	R1/8"	74,6	100,0	PAE210	US210	CO	CC	35,10	23,20	2,4	
-	69,9	R1/8"	***	***	PAE210	ES210	***	***	35,10	23,20	2,5	
-	69,9	R1/8"	***	***	PAE210	EX210	***	***	35,10	23,20	2,7	
-	75,0	R1/8"	75,2	110,0	PAE211	UK211 + H2311	CO	CC	43,55	29,20	3,3	55
69,0	-	R1/8"	75,2	110,0	PAE211	UC211	CO	CC	43,55	29,20	3,2	
69,0	-	R1/8"	75,2	110,0	PAE211	US211	CO	CC	43,55	29,20	3,2	
-	76,2	R1/8"	***	***	PAE211	ES211	***	***	43,55	29,20	3,0	
-	76,2	R1/8"	***	***	PAE211	EX211	***	***	43,55	29,20	3,5	
-	80,0	R1/8"	87,8	120,0	PAE212	UK212 + H2312	CO	CC	52,50	32,80	4,0	60
74,9	-	R1/8"	87,8	120,0	PAE212	UC212	CO	CC	52,50	32,80	4,0	
74,9	-	R1/8"	87,8	120,0	PAE212	US212	CO	CC	52,50	32,80	3,8	
-	84,2	R1/8"	***	***	PAE212	ES212	***	***	52,50	32,80	3,7	
-	84,2	R1/8"	***	***	PAE212	EX212	***	***	52,50	32,80	4,4	

* = mit zwei offenen Schutzkappen für durchgehende Wellen: Nachsetzzeichen CO wie Bestellbeispiel Seite 6

** = mit einer offenen und einer geschlossenen Schutzkappe für Wellenenden: Nachsetzzeichen CC wie Bestellbeispiel Seite 6

*** = mit Schutzkappen für Einsätze mit Excenterring auf Anfrage lieferbar

Gehäuse PG200 nachschmierbar

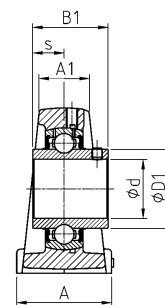
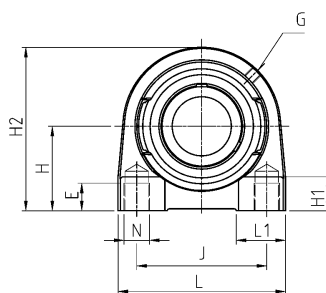
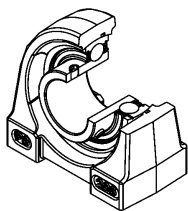

UCPG200

Wellendurchmesser
Einheit

Hauptabmessungen in mm

d [mm]		L	H	A1	A	J	N	E	L1	H1	H2	s1	B	B1	s
12	UCPG201	70	33,3	20	38	49	M8	16	21	14	64	-	-	31,0	12,7
	USPG201	55	30,2	13	30	38	M6	15	17	14	57	-	-	22,0	6,0
	ESPG201	55	30,2	13	30	38	M6	15	17	14	57	-	-	28,6	6,5
	EXPG201	70	33,3	20	38	49	M8	16	21	14	64	-	-	43,5	17,0
15	UCPG202	70	33,3	20	38	49	M8	16	21	14	64	-	-	31,0	12,7
	USPG202	55	30,2	13	30	38	M6	15	17	14	57	-	-	22,0	6,0
	ESPG202	55	30,2	13	30	38	M6	15	17	14	57	-	-	28,6	6,5
	EXPG202	70	33,3	20	38	49	M8	16	21	14	64	-	-	43,5	17,0
17	UCPG203	70	33,3	20	38	49	M8	16	21	14	64	-	-	31,0	12,7
	USPG203	55	30,2	13	30	38	M6	15	17	14	57	-	-	22,0	6,0
	ESPG203	55	30,2	13	30	38	M6	15	17	14	57	-	-	28,6	6,5
	EXPG203	70	33,3	20	38	49	M8	16	21	14	64	-	-	43,5	17,0
20	UCPG204	70	33,3	20	38	49	M8	16	21	14	64	-	-	31,0	12,7
	USPG204	70	33,3	20	38	49	M8	16	21	14	64	-	-	25,0	7,0
	ESPG204	70	33,3	20	38	49	M8	16	21	14	64	-	-	30,9	7,5
	EXPG204	70	33,3	20	38	49	M8	16	21	14	64	-	-	43,5	17,0
	UKPG205H	75	36,5	25	38	50	M10	18	25	15	70	18,5	35,0	-	-
25	UCPG205	75	36,5	25	38	50	M10	18	25	15	70	-	-	34,0	14,3
	USPG205	75	36,5	25	38	50	M10	18	25	15	70	-	-	27,0	7,5
	ESPG205	75	36,5	25	38	50	M10	18	25	15	70	-	-	30,9	7,5
	EXPG205	75	36,5	25	38	50	M10	18	25	15	70	-	-	44,3	17,4
	UKPG206H	85	42,9	25	48	60	M10	18	25	17	83	20,5	38,0	-	-
30	UCPG206	85	42,9	25	48	60	M10	18	25	17	83	-	-	38,1	15,9
	USPG206	85	42,9	25	48	60	M10	18	25	17	83	-	-	30,0	8,0
	ESPG206	85	42,9	25	48	60	M10	18	25	17	83	-	-	35,7	9,0
	EXPG206	85	42,9	25	48	60	M10	18	25	17	83	-	-	48,3	18,2
	UKPG207H	100	47,6	27	48	68	M12	22	35	20	93	22,5	43,0	-	-
35	UCPG207	100	47,6	27	48	68	M12	22	35	20	93	-	-	42,9	17,5
	USPG207	100	47,6	27	48	68	M12	22	35	20	93	-	-	32,0	8,5
	ESPG207	100	47,6	27	48	68	M12	22	35	20	93	-	-	38,9	9,5
	EXPG207	100	47,6	27	48	68	M12	22	35	20	93	-	-	51,1	18,8
	UKPG208H	110	49,2	30	54	78	M12	22	35	20	98	24,5	46,0	-	-
40	UCPG208	110	49,2	30	54	78	M12	22	35	20	98	-	-	49,2	19,0
	USPG208	110	49,2	30	54	78	M12	22	35	20	98	-	-	34,0	9,0
	ESPG208	110	49,2	30	54	78	M12	22	35	20	98	-	-	43,7	11,0
	EXPG208	110	49,2	30	54	78	M12	22	35	20	98	-	-	56,3	21,4
	UKPG209H	120	53,9	33	54	85	M12	22	40	20	106	26,0	50,0	-	-

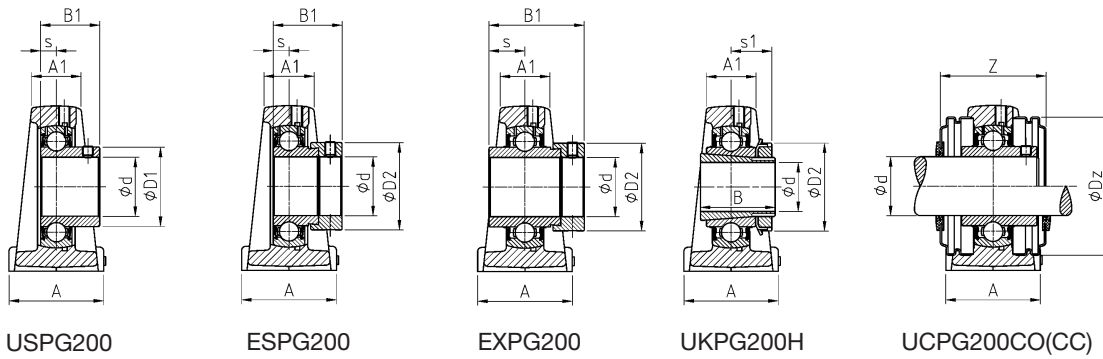

USPG200

ESPG200

EXP200

UKPG200H

UCPG200CO(CC)

D1	D2	G	Z	Dz	Gehäuse	Einsatz	Schutzkappen offen *	Schutzkappen geschlossen **	Tragzahl dyn.	Tragzahl stat.	Gewicht	Wellendurch- messer
D1	D2	G	Z	Dz					C _r [kN]	C _{or} [kN]	[kg]	d [mm]
29,0	-	M6x1	44,6	54,0	PG204	UC201	CO	CC	12,80	6,65	0,6	12
24,6	-	M6x1	40,6	46,0	PG203	US201	CO	CC	9,55	4,78	0,3	
-	28,6	M6x1	***	***	PG203	ES201	***	***	9,55	4,78	0,4	
-	33,3	M6x1	***	***	PG204	EX201	***	***	12,80	6,65	0,7	
29,0	-	M6x1	44,6	54,0	PG204	UC202	CO	CC	12,80	6,65	0,6	15
24,6	-	M6x1	40,6	46,0	PG203	US202	CO	CC	9,55	4,78	0,3	
-	28,6	M6x1	***	***	PG203	ES202	***	***	9,55	4,78	0,4	
-	33,3	M6x1	***	***	PG204	EX202	***	***	12,80	6,65	0,7	
29,0	-	M6x1	44,6	54,0	PG204	UC203	CO	CC	12,80	6,65	0,4	17
24,6	-	M6x1	40,6	46,0	PG203	US203	CO	CC	9,55	4,78	0,3	
-	28,6	M6x1	***	***	PG203	ES203	***	***	9,55	4,78	0,4	
-	33,3	M6x1	***	***	PG204	EX203	***	***	12,80	6,65	0,7	
29,0	-	M6x1	44,6	54,0	PG204	UC204	CO	CC	12,80	6,65	0,6	20
29,0	-	M6x1	42,6	54,0	PG204	US204	CO	CC	12,80	6,65	0,6	
-	33,3	M6x1	***	***	PG204	ES204	***	***	12,80	6,65	0,6	
-	33,3	M6x1	***	***	PG204	EX204	***	***	12,80	6,65	0,6	
-	38,0	M6x1	47,8	60,0	PG205	UK205 + H2305	CO	CC	14,00	7,88	0,7	
34,0	-	M6x1	47,8	60,0	PG205	UC205	CO	CC	14,00	7,88	0,7	25
34,0	-	M6x1	47,8	60,0	PG205	US205	CO	CC	14,00	7,88	0,7	
-	38,1	M6x1	***	***	PG205	ES205	***	***	14,00	7,88	0,7	
-	38,1	M6x1	***	***	PG205	EX205	***	***	14,00	7,88	0,7	
-	45,0	M6x1	52,8	70,0	PG206	UK206 + H2306	CO	CC	19,50	11,20	1,1	
40,3	-	M6x1	52,8	70,0	PG206	UC206	CO	CC	19,50	11,20	1,1	30
40,3	-	M6x1	52,8	70,0	PG206	US206	CO	CC	19,50	11,20	1,0	
-	44,5	M6x1	***	***	PG206	ES206	***	***	19,50	11,20	1,1	
-	44,5	M6x1	***	***	PG206	EX206	***	***	19,50	11,20	1,2	
-	52,0	M6x1	57,4	80,0	PG207	UK207 + H2307	CO	CC	25,70	15,20	1,6	
48,0	-	M6x1	57,4	80,0	PG207	UC207	CO	CC	25,70	15,20	1,5	35
48,0	-	M6x1	57,4	80,0	PG207	US207	CO	CC	25,70	15,20	1,5	
-	55,6	M6x1	***	***	PG207	ES207	***	***	25,70	15,20	1,6	
-	55,6	M6x1	***	***	PG207	EX207	***	***	25,70	15,20	1,7	
-	58,0	M6x1	66,8	88,0	PG208	UK208 + H2308	CO	CC	29,60	18,20	1,9	
53,0	-	M6x1	66,8	88,0	PG208	UC208	CO	CC	29,60	18,20	1,8	40
53,0	-	M6x1	66,8	88,0	PG208	US208	CO	CC	29,60	18,20	1,8	
-	60,3	M6x1	***	***	PG208	ES208	***	***	29,60	18,20	1,8	
-	60,3	M6x1	***	***	PG208	EX208	***	***	29,60	18,20	2,0	
-	65,0	M6x1	67,8	95,0	PG209	UK209 + H2309	CO	CC	31,85	20,80	2,3	

* = mit zwei offenen Schutzkappen für durchgehende Wellen: Nachsetzzeichen CO wie Bestellbeispiel Seite 6

** = mit einer offenen und einer geschlossenen Schutzkappe für Wellenenden: Nachsetzzeichen CC wie Bestellbeispiel Seite 6

*** = mit Schutzkappen für Einsätze mit Excenterring auf Anfrage lieferbar

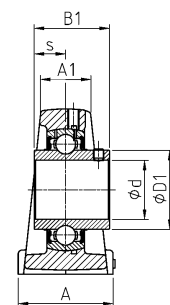
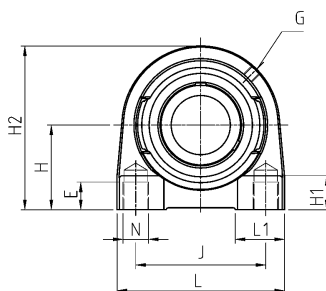
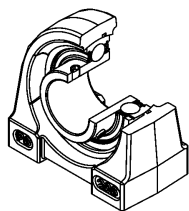

UCPG200

Wellendurchmesser		Einheit		Hauptabmessungen in mm												
d [mm]		L	H	A1	A	J	N	E	L1	H1	H2	s1	B	B1	s	
45	UCPG209	120	53,9	33	54	85	M12	22	40	20	106	-	-	49,2	19,0	
	USPG209	120	53,9	33	54	85	M12	22	40	20	106	-	-	41,2	10,2	
	ESPG209	120	53,9	33	54	85	M12	22	40	20	106	-	-	43,7	11,0	
	EXPG209	120	53,9	33	54	85	M12	22	40	20	106	-	-	56,3	21,4	
	UKPG210H	135	57,2	35	60	95	M16	25	40	21	114	27,5	55,0	-	-	
50	UCPG210	135	57,2	35	60	95	M16	25	40	21	114	-	-	51,6	19,0	
	USPG210	135	57,2	35	60	95	M16	25	40	21	114	-	-	43,5	10,9	
	ESPG210	135	57,2	35	60	95	M16	25	40	21	114	-	-	43,7	11,0	
	EXPG210	135	57,2	35	60	95	M16	25	40	21	114	-	-	62,7	24,6	
	UKPG211H	140	63,5	34	60	100	M16	25	40	25	126	29,0	59,0	-	-	
55	UCPG211	140	63,5	34	60	100	M16	25	40	25	126	-	-	55,6	22,2	
	USPG211	140	63,5	34	60	100	M16	25	40	25	126	-	-	45,3	11,8	
	ESPG211	140	63,5	34	60	100	M16	25	40	25	126	-	-	48,4	12,0	
	EXPG211	140	63,5	34	60	100	M16	25	40	25	126	-	-	71,3	27,7	
	UKPG212H	150	69,8	40	70	105	M16	25	50	25	138	31,0	62,0	-	-	
60	UCPG212	150	69,8	40	70	105	M16	25	50	25	138	-	-	65,1	25,4	
	USPG212	150	69,8	40	70	105	M16	25	50	25	138	-	-	53,7	14,9	
	ESPG212	150	69,8	40	70	105	M16	25	50	25	138	-	-	49,3	12,0	
	EXPG212	150	69,8	40	70	105	M16	25	50	25	138	-	-	77,7	30,9	

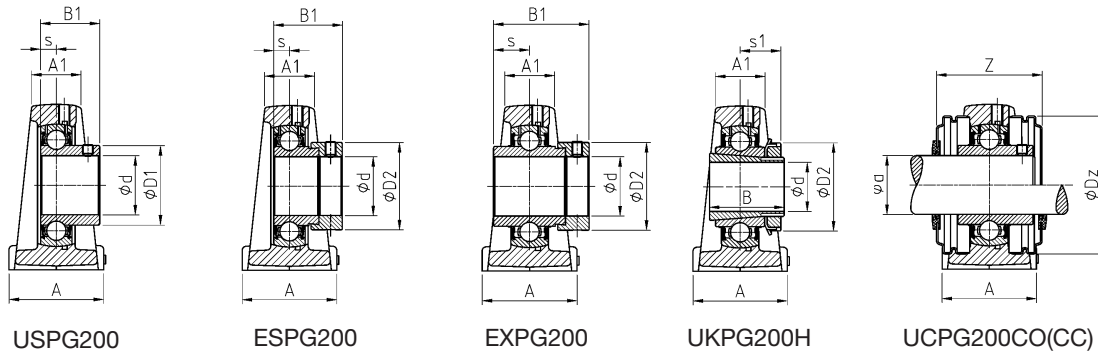

USP200

ESPG200

EXPG200

UKPG200H

UCPG200CO(CC)

D1	D2	G	Z	Dz	Gehäuse	Einsatz	Schutzkappen offen *	Schutzkappen geschlossen **	Tragzahl dyn.	Tragzahl stat.	Gewicht	Wellendurch- messer
D1	D2	G	Z	Dz					C _r [kN]	C _{or} [kN]	[kg]	d [mm]
57,2	-	M6x1	67,8	95,0	PG209	UC209	CO	CC	31,85	20,80	2,2	45
57,2	-	M6x1	67,8	95,0	PG209	US209	CO	CC	31,85	20,80	2,1	45
-	63,5	M6x1	***	***	PG209	ES209	***	***	31,85	20,80	2,2	45
-	63,5	M6x1	***	***	PG209	EX209	***	***	31,85	20,80	2,4	45
-	70,0	M6x1	74,6	100,0	PG210	UK210 + H2310	CO	CC	35,10	23,20	2,9	45
61,8	-	M6x1	74,6	100,0	PG210	UC210	CO	CC	35,10	23,20	2,8	50
61,8	-	M6x1	74,6	100,0	PG210	US210	CO	CC	35,10	23,20	2,8	50
-	69,9	M6x1	***	***	PG210	ES210	***	***	35,10	23,20	2,8	50
-	69,9	M6x1	***	***	PG210	EX210	***	***	35,10	23,20	3,0	50
-	75,0	M6x1	75,2	110,0	PG211	UK211 + H2311	CO	CC	43,55	29,20	3,5	50
69,0	-	M6x1	75,2	110,0	PG211	UC211	CO	CC	43,55	29,20	3,5	55
69,0	-	M6x1	75,2	110,0	PG211	US211	CO	CC	43,55	29,20	3,4	55
-	76,2	M6x1	***	***	PG211	ES211	***	***	43,55	29,20	3,2	55
-	76,2	M6x1	***	***	PG211	EX211	***	***	43,55	29,20	3,7	55
-	80,0	M6x1	87,8	120,0	PG212	UK212 + H2312	CO	CC	52,50	32,80	4,7	60
74,9	-	M6x1	87,8	120,0	PG212	UC212	CO	CC	52,50	32,80	4,7	60
74,9	-	M6x1	87,8	120,0	PG212	US212	CO	CC	52,50	32,80	4,5	60
-	84,2	M6x1	***	***	PG212	ES212	***	***	52,50	32,80	4,4	60
-	84,2	M6x1	***	***	PG212	EX212	***	***	52,50	32,80	5,0	60

* = mit zwei offenen Schutzkappen für durchgehende Wellen: Nachsetzzeichen CO wie Bestellbeispiel Seite 6

** = mit einer offenen und einer geschlossenen Schutzkappe für Wellenenden: Nachsetzzeichen CC wie Bestellbeispiel Seite 6

*** = mit Schutzkappen für Einsätze mit Excenterring auf Anfrage lieferbar

Gehäuse PA200 nachschmierbar

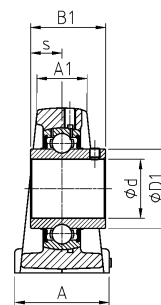
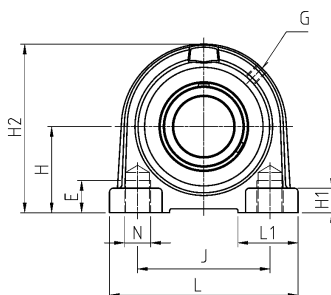
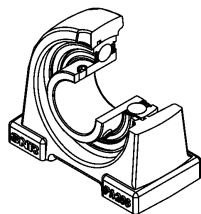

UCPA200

Wellendurchmesser
Einheit

Hauptabmessungen in mm

d [mm]		L	H	A1	A	J	N	E	L1	H1	H2	s1	B	B1	s
12	UCPA201	76	30,2	22	40	52	M10	13	22	11	62	-	-	31,0	12,7
	USPA201	70	30,2	19	36	48	M8	9	20	10	57	-	-	22,0	6,0
	ESPA201	70	30,2	19	36	48	M8	9	20	10	57	-	-	28,6	6,5
	EXPA201	76	30,2	22	40	52	M10	13	22	11	62	-	-	43,5	17,0
15	UCPA202	76	30,2	22	40	52	M10	13	22	11	62	-	-	31,0	12,7
	USPA202	70	30,2	19	36	48	M8	9	20	10	57	-	-	22,0	6,0
	ESPA202	70	30,2	19	36	48	M8	9	20	10	57	-	-	28,6	6,5
	EXPA202	76	30,2	22	40	52	M10	13	22	11	62	-	-	43,5	17,0
17	UCPA203	76	30,2	22	40	52	M10	13	22	11	62	-	-	31,0	12,7
	USPA203	70	30,2	19	36	48	M8	9	20	10	57	-	-	22,0	6,0
	ESPA203	70	30,2	19	36	48	M8	9	20	10	57	-	-	28,6	6,5
	EXPA203	76	30,2	22	40	52	M10	13	22	11	62	-	-	43,5	17,0
20	UCPA204	76	30,2	22	40	52	M10	13	22	11	62	-	-	31,0	12,7
	USPA204	76	30,2	22	40	52	M10	13	22	11	62	-	-	25,0	7,0
	ESPA204	76	30,2	22	40	52	M10	13	22	11	62	-	-	30,9	7,5
	EXPA204	76	30,2	22	40	52	M10	13	22	11	62	-	-	43,5	17,0
	UKPA205H	84	36,5	23	38	56	M10	15	27	12	72	18,5	35,0	-	-
25	UCPA205	84	36,5	23	38	56	M10	15	27	12	72	-	-	34,0	14,3
	USPA205	84	36,5	23	38	56	M10	15	27	12	72	-	-	27,0	7,5
	ESPA205	84	36,5	23	38	56	M10	15	27	12	72	-	-	30,9	7,5
	EXPA205	84	36,5	23	38	56	M10	15	27	12	72	-	-	44,3	17,4
	UKPA206H	94	42,9	25	48	66	M14	18	30	13	84	20,5	38,0	-	-
30	UCPA206	94	42,9	25	48	66	M14	18	30	13	84	-	-	38,1	15,9
	USPA206	94	42,9	25	48	66	M14	18	30	13	84	-	-	30,0	8,0
	ESPA206	94	42,9	25	48	66	M14	18	30	13	84	-	-	35,7	9,0
	EXPA206	94	42,9	25	48	66	M14	18	30	13	84	-	-	48,3	18,2
	UKPA207H	110	47,6	27	48	80	M14	20	30	13	95	22,5	43,0	-	-
35	UCPA207	110	47,6	27	48	80	M14	20	30	13	95	-	-	42,9	17,5
	USPA207	110	47,6	27	48	80	M14	20	30	13	95	-	-	32,0	8,5
	ESPA207	110	47,6	27	48	80	M14	20	30	13	95	-	-	38,9	9,5
	EXPA207	110	47,6	27	48	80	M14	20	30	13	95	-	-	51,1	18,8
	UKPA208H	116	49,2	28	54	84	M14	20	32	13	100	24,5	46,0	-	-
40	UCPA208	116	49,2	28	54	84	M14	20	32	13	100	-	-	49,2	19,0
	USPA208	116	49,2	28	54	84	M14	20	32	13	100	-	-	34,0	9,0
	ESPA208	116	49,2	28	54	84	M14	20	32	13	100	-	-	43,7	11,0
	EXPA208	116	49,2	28	54	84	M14	20	32	13	100	-	-	56,3	21,4
	UKPA209H	120	54,2	32	60	90	M14	25	42	13	108	26,0	50,0	-	-

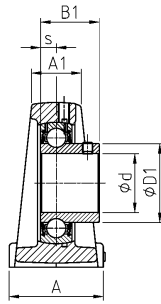

USA200

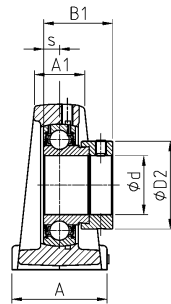

ESA200

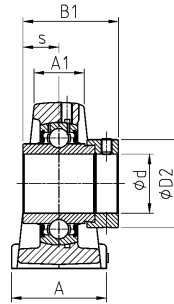

EXA200

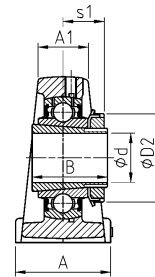

UKA200H

D1	D2	G	Z	Dz	Gehäuse	Einsatz	Schutzkappen offen*	Schutzkappen geschlossen**	Tragzahl dyn.	Tragzahl stat.	Gewicht	Wellendurch- messer
									C_r [kN]	C_{or} [kN]	[kg]	d [mm]
29,0	-	M6x1	45,6	54	PA204	UC201	CO	CC	12,80	6,65	0,6	12
24,6	-	M6x1	42,6	46	PA203	US201	CO	CC	9,55	4,78	0,4	
-	28,6	M6x1	64	***	PA203	ES201	***	***	9,55	4,78	0,4	
-	33,3	M6x1	56	***	PA204	EX201	***	***	12,80	6,65	0,7	
29,0	-	M6x1	45,6	54	PA204	UC202	CO	CC	12,80	6,65	0,6	15
24,6	-	M6x1	42,6	46	PA203	US202	CO	CC	9,55	4,78	0,4	
-	28,6	M6x1	64	***	PA203	ES202	***	***	9,55	4,78	0,4	
-	33,3	M6x1	56	***	PA204	EX202	***	***	12,80	6,65	0,6	
29,0	-	M6x1	45,6	54	PA204	UC203	CO	CC	12,80	6,65	0,5	17
24,6	-	M6x1	42,6	46	PA203	US203	CO	CC	9,55	4,78	0,4	
-	28,6	M6x1	64	***	PA203	ES203	***	***	9,55	4,78	0,4	
-	33,3	M6x1	56	***	PA204	EX203	***	***	12,80	6,65	0,6	
29,0	-	M6x1	45,6	54	PA204	UC204	CO	CC	12,80	6,65	0,5	20
29,0	-	M6x1	45,6	54	PA204	US204	CO	CC	12,80	6,65	0,5	
-	33,3	M6x1	64	***	PA204	ES204	***	***	12,80	6,65	0,5	
-	33,3	M6x1	64	***	PA204	EX204	***	***	12,80	6,65	0,6	
-	38,0	M6x1	48	60	PA205	UK205 + H2305	CO	CC	14,00	7,88	0,8	
34,0	-	M6x1	48	60	PA205	UC205	CO	CC	14,00	7,88	0,7	25
34,0	-	M6x1	48	60	PA205	US205	CO	CC	14,00	7,88	0,7	
-	38,1	M6x1	65,2	***	PA205	ES205	***	***	14,00	7,88	0,7	
-	38,1	M6x1	65,2	***	PA205	EX205	***	***	14,00	7,88	0,8	
-	45,0	M6x1	51,8	70	PA206	UK206 + H2306	CO	CC	19,50	11,20	1,1	
40,3	-	M6x1	51,8	70	PA206	UC206	CO	CC	19,50	11,20	1,1	30
40,3	-	M6x1	51,8	70	PA206	US206	CO	CC	19,50	11,20	1,0	
-	44,5	M6x1	70	***	PA206	ES206	***	***	19,50	11,20	1,1	
-	44,5	M6x1	70	***	PA206	EX206	***	***	19,50	11,20	1,2	
-	52,0	M6x1	60	80	PA207	UK207 + H2307	CO	CC	25,70	15,20	1,5	
48,0	-	M6x1	60	80	PA207	UC207	CO	CC	25,70	15,20	1,5	35
48,0	-	M6x1	60	80	PA207	US207	CO	CC	25,70	15,20	1,4	
-	55,6	M6x1	78,6	***	PA207	ES207	***	***	25,70	15,20	1,5	
-	55,6	M6x1	78,6	***	PA207	EX207	***	***	25,70	15,20	1,6	
-	58,0	M6x1	68,4	88	PA208	UK208 + H2308	CO	CC	29,60	18,20	1,8	
53,0	-	M6x1	68,4	88	PA208	UC208	CO	CC	29,60	18,20	1,8	40
53,0	-	M6x1	68,4	88	PA208	US208	CO	CC	29,60	18,20	1,7	
-	60,3	M6x1	80,6	***	PA208	ES208	***	***	29,60	18,20	1,8	
-	60,3	M6x1	80,6	***	PA208	EX208	***	***	29,60	18,20	1,9	
-	65,0	M6x1	70,2	95	PA209	UK209 + H2309	CO	CC	31,85	20,80	2,2	

* = mit einer offenen Schutzkappe für durchgehende Wellen: Nachsetzzeichen CO wie Bestellbeispiel Seite 6

** = mit einer geschlossenen Schutzkappe für Wellenenden: Nachsetzzeichen CC wie Bestellbeispiel Seite 6

*** = mit Schutzkappen für Einsätze mit Excentering auf Anfrage lieferbar

Gehäuse PA200 nachschmierbar

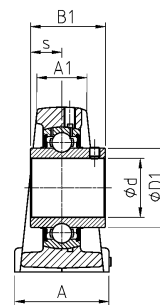
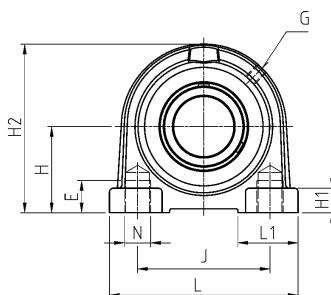
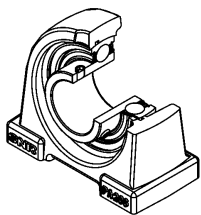

UCPA200

Wellendurchmesser
Einheit

Hauptabmessungen in mm

d [mm]		L	H	A1	A	J	N	E	L1	H1	H2	s1	B	B1	s
45	UCPA209	120	54,2	32	60	90	M14	25	42	13	108	-	-	49,2	19,0
	USPA209	120	54,2	32	60	90	M14	25	42	13	108	-	-	41,2	10,2
	ESPA209	120	54,2	32	60	90	M14	25	42	13	108	-	-	43,7	11,0
	EXPA209	120	54,2	32	60	90	M14	25	42	13	108	-	-	56,3	21,4
	UKPA210H	130	57,2	32	60	94	M16	25	35	14	116	27,5	55,0	-	-
50	UCPA210	130	57,2	32	60	94	M16	25	35	14	116	-	-	51,6	19,0
	USPA210	130	57,2	32	60	94	M16	25	35	14	116	-	-	43,5	10,9
	ESPA210	130	57,2	32	60	94	M16	25	35	14	116	-	-	43,7	11,0
	EXPA210	130	57,2	32	60	94	M16	25	35	14	116	-	-	62,7	24,6
	UKPA211H	140	63,5	33	66	104	M16	25	47	14	125	29,0	59,0	-	-
55	UCPA211	140	63,5	33	66	104	M16	25	47	14	125	-	-	55,6	22,2
	USPA211	140	63,5	33	66	104	M16	25	47	14	125	-	-	45,3	11,8
	ESPA211	140	63,5	33	66	104	M16	25	47	14	125	-	-	48,4	12,0
	EXPA211	140	63,5	33	66	104	M16	25	47	14	125	-	-	71,3	27,7
	UKPA212H	150	69,9	36	68	114	M16	25	52	15	138	31,0	62,0	-	-
60	UCPA212	150	69,9	36	68	114	M16	25	52	15	138	-	-	65,1	25,4
	USPA212	150	69,9	36	68	114	M16	25	52	15	138	-	-	53,7	14,9
	ESPA212	150	69,9	36	68	114	M16	25	52	15	138	-	-	49,3	12,0
	EXPA212	150	69,9	36	68	114	M16	25	52	15	138	-	-	77,7	30,9

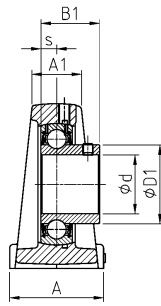

USPA200

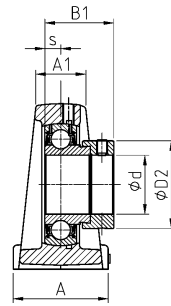

ESPA200

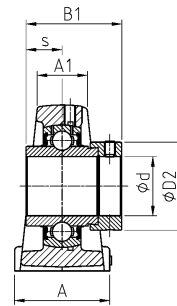

EXPA200

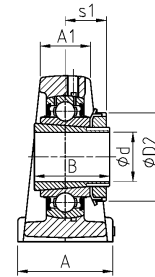

UKPA200H

D1	D2	G	Z	Dz	Gehäuse	Einsatz	Schutzkappe offen *	Schutzkappe- geschlossen **	Tragzahl dyn.	Tragzahl stat.	Gewicht	Wellendurch- messer
									C_r [kN]	C_{or} [kN]	[kg]	d [mm]
57,2	-	M6x1	70,2	95	PA209	UC209	CO	CC	31,85	20,80	2,1	45
57,2	-	M6x1	70,2	95	PA209	US209	CO	CC	31,85	20,80	2,1	
-	63,5	M6x1	84,4	***	PA209	ES209	***	***	31,85	20,80	2,1	
-	63,5	M6x1	84,4	***	PA209	EX209	***	***	31,85	20,80	2,3	
-	70,0	M6x1	75,6	100	PA210	UK210 + H2310	CO	CC	35,10	23,20	2,7	50
61,8	-	M6x1	75,6	100	PA210	UC210	CO	CC	35,10	23,20	2,6	
61,8	-	M6x1	75,6	100	PA210	US210	CO	CC	35,10	23,20	2,5	
-	69,9	M6x1	91	***	PA210	ES210	***	***	35,10	23,20	2,6	
-	69,9	M6x1	91	***	PA210	EX210	***	***	35,10	23,20	2,8	
-	75,0	M6x1	77	110	PA211	UK211 + H2311	CO	CC	43,55	29,20	3,3	55
69,0	-	M6x1	77	110	PA211	UC211	CO	CC	43,55	29,20	3,2	
69,0	-	M6x1	77	110	PA211	US211	CO	CC	43,55	29,20	3,1	
-	76,2	M6x1	103,8	***	PA211	ES211	***	***	43,55	29,20	2,9	
-	76,2	M6x1	103,8	***	PA211	EX211	***	***	43,55	29,20	3,5	
-	80,0	M6x1	90	120	PA212	UK212 + H2312	CO	CC	52,50	32,80	4,1	
74,9	-	M6x1	90	120	PA212	UC212	CO	CC	52,50	32,80	4,1	60
74,9	-	M6x1	90	120	PA212	US212	CO	CC	52,50	32,80	3,9	
-	84,2	M6x1	111,2	***	PA212	ES212	***	***	52,50	32,80	3,8	
-	84,2	M6x1	111,2	***	PA212	EX212	***	***	52,50	32,80	4,5	

* = mit einer offenen Schutzkappe für durchgehende Wellen: Nachsetzzeichen CO wie Bestellbeispiel Seite 6

** = mit einer geschlossenen Schutzkappe für Wellenenden: Nachsetzzeichen CC wie Bestellbeispiel Seite 6

*** = mit Schutzkappen für Einsätze mit Excenterring auf Anfrage lieferbar

Gehäuse FE200 nachschmierbar

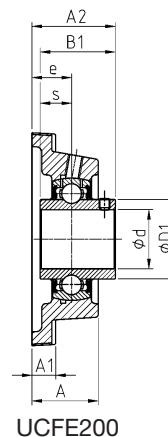
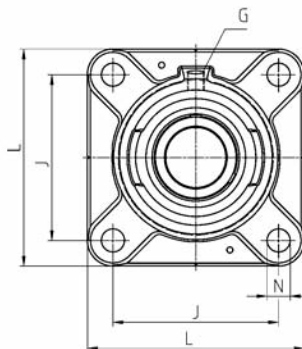
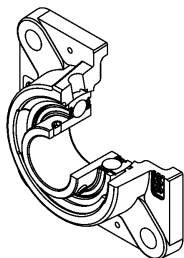

UCFE200

Wellendurchmesser
Einheit

Hauptabmessungen in mm

d [mm]		L	J	A	A1	A2	e	N	s1	B	B1	s	D1
12	UCFE201	86	63,5	29,5	10,0	37,3	19,0	11,5	-	-	31,0	12,7	29,0
	USFE201	76	54,0	31,0	9,5	33,0	17,0	11,5	-	-	22,0	6,0	24,6
	ESFE201	76	54,0	31,0	9,5	39,1	17,0	11,5	-	-	28,6	6,5	-
	EXFE201	86	63,5	29,5	10,0	45,5	19,0	11,5	-	-	43,5	17,0	-
15	UCFE202	86	63,5	29,5	10,0	37,3	19,0	11,5	-	-	31,0	12,7	29,0
	USFE202	76	54,0	31,0	9,5	33,0	17,0	11,5	-	-	22,0	6,0	24,6
	ESFE202	76	54,0	31,0	9,5	39,1	17,0	11,5	-	-	28,6	6,5	-
	EXFE202	86	63,5	29,5	10,0	45,5	19,0	11,5	-	-	43,5	17,0	-
17	UCFE203	86	63,5	29,5	10,0	37,3	19,0	11,5	-	-	31,0	12,7	29,0
	USFE203	76	54,0	31,0	9,5	33,0	17,0	11,5	-	-	22,0	6,0	24,6
	ESFE203	76	54,0	31,0	9,5	39,1	17,0	11,5	-	-	28,6	6,5	-
	EXFE203	86	63,5	29,5	10,0	45,5	19,0	11,5	-	-	43,5	17,0	-
20	UCFE204	86	63,5	29,5	10,0	37,3	19,0	11,5	-	-	31,0	12,7	29,0
	USFE204	86	63,5	29,5	10,0	37,0	19,0	11,5	-	-	25,0	7,0	29,0
	ESFE204	86	63,5	29,5	10,0	42,4	19,0	11,5	-	-	30,9	7,5	-
	EXFE204	86	63,5	29,5	10,0	45,5	19,0	11,5	-	-	43,5	17,0	-
	UKFE205H	95	70,0	30,0	11,0	37,5	19,0	11,5	18,5	35,0	-	-	-
25	UCFE205	95	70,0	30,0	11,0	38,7	19,0	11,5	-	-	34,0	14,3	34,0
	USFE205	95	70,0	30,0	11,0	38,5	19,0	11,5	-	-	27,0	7,5	34,0
	ESFE205	95	70,0	30,0	11,0	42,4	19,0	11,5	-	-	30,9	7,5	-
	EXFE205	95	70,0	30,0	11,0	45,9	19,0	11,5	-	-	44,3	17,4	-
	UKFE206H	108	82,5	33,5	12,0	40,5	20,0	11,5	20,5	38,0	-	-	-
30	UCFE206	108	82,5	33,5	12,0	42,2	20,0	11,5	-	-	38,1	15,9	40,3
	USFE206	108	82,5	33,5	12,0	42,0	20,0	11,5	-	-	30,0	8,0	40,3
	ESFE206	108	82,5	33,5	12,0	46,7	20,0	11,5	-	-	35,7	9,0	-
	EXFE206	108	82,5	33,5	12,0	50,1	20,0	11,5	-	-	48,3	18,2	-
	UKFE207H	118	92,0	36,0	12,5	43,5	21,0	14,0	22,5	43,0	-	-	-
35	UCFE207	118	92,0	36,0	12,5	46,4	21,0	14,0	-	-	42,9	17,5	48,0
	USFE207	118	92,0	36,0	12,5	44,5	21,0	14,0	-	-	32,0	8,5	48,0
	ESFE207	118	92,0	36,0	12,5	50,4	21,0	14,0	-	-	38,9	9,5	-
	EXFE207	118	92,0	36,0	12,5	53,3	21,0	14,0	-	-	51,1	18,8	-
	UKFE208H	130	101,5	39,5	13,0	48,5	24,0	14,0	24,5	46,0	-	-	-
40	UCFE208	130	101,5	39,5	13,0	54,2	24,0	14,0	-	-	49,2	19,0	53,0
	USFE208	130	101,5	39,5	13,0	49,0	24,0	14,0	-	-	34,0	9,0	53,0
	ESFE208	130	101,5	39,5	13,0	56,7	24,0	14,0	-	-	43,7	11,0	-
	EXFE208	130	101,5	39,5	13,0	58,9	24,0	14,0	-	-	56,3	21,4	-
	UKFE209H	137	105,0	40,0	13,0	50,0	24,0	14,0	26,0	50,0	-	-	-

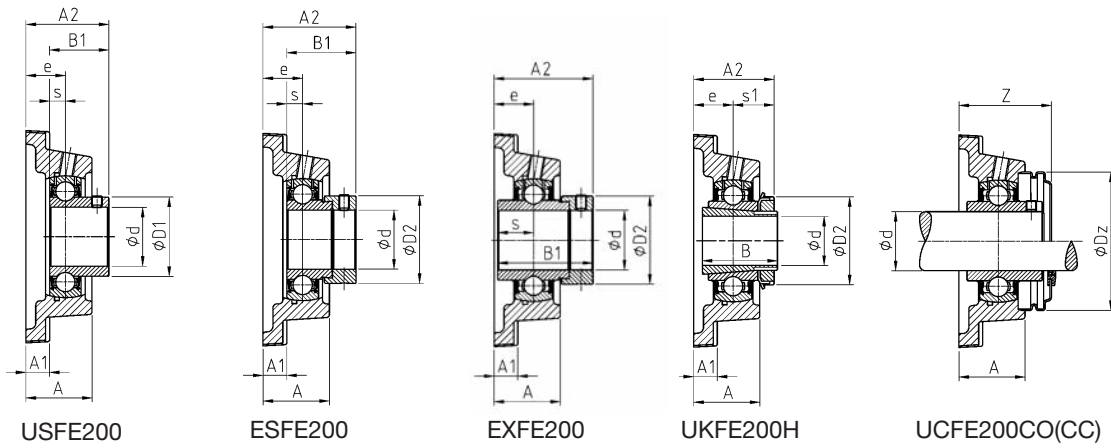

D2	G	Z	Dz	Gehäuse	Einsatz	Schutzkappe offen *	Schutzkappe geschlossen **	Tragzahl dyn.	Tragzahl stat.	Gewicht	Wellendurch- messer
								C_r [kN]	C_{or} [kN]	[kg]	d [mm]
-	R1/8"	42,8	54,0	FE204	UC201	CO	CC	12,80	6,65	0,7	12
-	M6x1	42,8	46,0	FE203	US201	CO	CC	9,55	4,78	0,4	
28,6	M6x1	***	***	FE203	ES201	***	***	9,55	4,78	0,5	
33,3	R1/8"	***	***	FE204	EX201	***	***	12,80	6,65	0,8	
-	R1/8"	42,8	54,0	FE204	UC202	CO	CC	12,80	6,65	0,7	15
-	M6x1	42,8	46,0	FE203	US202	CO	CC	9,55	4,78	0,4	
28,6	M6x1	***	***	FE203	ES202	***	***	9,55	4,78	0,5	
33,3	R1/8"	***	***	FE204	EX202	***	***	12,80	6,65	0,8	
-	R1/8"	42,8	54,0	FE204	UC203	CO	CC	12,80	6,65	0,5	17
-	M6x1	42,8	46,0	FE203	US203	CO	CC	9,55	4,78	0,4	
28,6	M6x1	***	***	FE203	ES203	***	***	9,55	4,78	0,5	
33,3	R1/8"	***	***	FE204	EX203	***	***	12,80	6,65	0,8	
-	R1/8"	42,8	54,0	FE204	UC204	CO	CC	12,80	6,65	0,7	20
-	R1/8"	42,8	54,0	FE204	US204	CO	CC	12,80	6,65	0,6	
33,3	R1/8"	***	***	FE204	ES204	***	***	12,80	6,65	0,7	
33,3	R1/8"	***	***	FE204	EX204	***	***	12,80	6,65	0,7	
38,0	R1/8"	42,9	60,0	FE205	UK205 + H2305	CO	CC	14,00	7,88	0,8	
-	R1/8"	42,9	60,0	FE205	UC205	CO	CC	14,00	7,88	0,8	25
-	R1/8"	42,9	60,0	FE205	US205	CO	CC	14,00	7,88	0,8	
38,1	R1/8"	***	***	FE205	ES205	***	***	14,00	7,88	0,8	
38,1	R1/8"	***	***	FE205	EX205	***	***	14,00	7,88	0,9	
45,0	R1/8"	46,9	70,0	FE206	UK206 + H2306	CO	CC	19,50	11,20	1,2	
-	R1/8"	46,9	70,0	FE206	UC206	CO	CC	19,50	11,20	1,2	30
-	R1/8"	46,9	70,0	FE206	US206	CO	CC	19,50	11,20	1,1	
44,5	R1/8"	***	***	FE206	ES206	***	***	19,50	11,20	1,2	
44,5	R1/8"	***	***	FE206	EX206	***	***	19,50	11,20	1,3	
52,0	R1/8"	50,2	80,0	FE207	UK207 + H2307	CO	CC	25,70	15,20	1,6	
-	R1/8"	50,2	80,0	FE207	UC207	CO	CC	25,70	15,20	1,6	35
-	R1/8"	50,2	80,0	FE207	US207	CO	CC	25,70	15,20	1,5	
55,6	R1/8"	***	***	FE207	ES207	***	***	25,70	15,20	1,6	
55,6	R1/8"	***	***	FE207	EX207	***	***	25,70	15,20	1,7	
58,0	R1/8"	57,9	88,0	FE208	UK208 + H2308	CO	CC	29,60	18,20	2,1	
-	R1/8"	57,9	88,0	FE208	UC208	CO	CC	29,60	18,20	2,1	40
-	R1/8"	57,9	88,0	FE208	US208	CO	CC	29,60	18,20	2,0	
60,3	R1/8"	***	***	FE208	ES208	***	***	29,60	18,20	2,1	
60,3	R1/8"	***	***	FE208	EX208	***	***	29,60	18,20	2,2	
65,0	R1/8"	58,4	95,0	FE209	UK209 + H2309	CO	CC	31,85	20,80	2,4	

* = mit einer offenen Schutzkappe für durchgehende Wellen: Nachsetzzeichen CO wie Bestellbeispiel Seite 6

** = mit einer geschlossenen Schutzkappe für Wellenenden: Nachsetzzeichen CC wie Bestellbeispiel Seite 6

*** = mit Schutzkappen für Einsätze mit Excentering auf Anfrage lieferbar

Gehäuse FE200 nachschmierbar

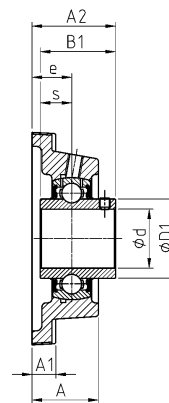
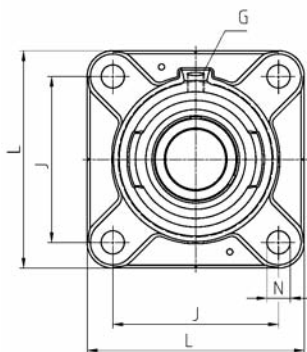
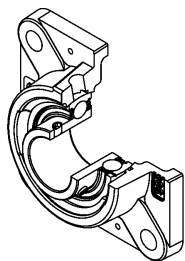

UCFE200

Wellendurchmesser
Einheit

Hauptabmessungen in mm

d [mm]		L	J	A	A1	A2	e	N	s1	B	B1	s	D1
45	UCFE209	137	105,0	40,0	13,0	54,2	24,0	14,0	-	-	49,2	19,0	57,2
	USFE209	137	105,0	40,0	13,0	55,0	24,0	14,0	-	-	41,2	10,2	57,2
	ESFE209	137	105,0	40,0	13,0	56,7	24,0	14,0	-	-	43,7	11,0	-
	EXFE209	137	105,0	40,0	13,0	58,9	24,0	14,0	-	-	56,3	21,4	-
	UKFE210H	143	111,0	44,0	13,0	55,5	28,0	18,0	27,5	55,0	-	-	-
50	UCFE210	143	111,0	44,0	13,0	60,6	28,0	18,0	-	-	51,6	19,0	61,8
	USFE210	143	111,0	44,0	13,0	60,6	28,0	18,0	-	-	43,5	10,9	61,8
	ESFE210	143	111,0	44,0	13,0	60,7	28,0	18,0	-	-	43,7	11,0	-
	EXFE210	143	111,0	44,0	13,0	66,1	28,0	18,0	-	-	62,7	24,6	-
	UKFE211H	162	130,0	48,5	15,0	60,0	31,0	18,0	29,0	59,0	-	-	-
55	UCFE211	162	130,0	48,5	15,0	64,4	31,0	18,0	-	-	55,6	22,2	69,0
	USFE211	162	130,0	48,5	15,0	64,5	31,0	18,0	-	-	45,3	11,8	69,0
	ESFE211	162	130,0	48,5	15,0	67,4	31,0	18,0	-	-	48,4	12,0	-
	EXFE211	162	130,0	48,5	15,0	74,6	31,0	18,0	-	-	71,3	27,7	-
	UKFE212H	175	143,0	53,5	16,0	65,0	34,0	18,0	31,0	62,0	-	-	-
60	UCFE212	175	143,0	53,5	16,0	73,7	34,0	18,0	-	-	65,1	25,4	74,9
	USFE212	175	143,0	53,5	16,0	72,8	34,0	18,0	-	-	53,7	14,9	74,9
	ESFE212	175	143,0	53,5	16,0	71,3	34,0	18,0	-	-	49,3	12,0	-
	EXFE212	175	143,0	53,5	16,0	80,8	34,0	18,0	-	-	77,7	30,9	-
	UKFE213H	188	150,0	56,0	18,0	70,0	38,0	18,0	32,0	65,0	-	-	-
65	UCFE213	188	150,0	56,0	18,0	77,7	38,0	18,0	-	-	65,1	25,4	82,0
	EXFE213	188	150,0	56,0	18,0	89,6	38,0	18,0	-	-	85,7	34,1	-
	UKFE215H	197	153,0	59,0	20,0	76,8	41,3	23,0	35,5	73,0	-	-	-
70	UCFE214	188	150,0	56,0	18,0	82,4	38,0	18,0	-	-	74,6	30,2	86,5
	EXFE214	188	150,0	56,0	18,0	89,6	38,0	18,0	-	-	85,7	34,1	-
	UKFE216H	197	153,0	61,0	20,0	80,3	41,3	23,0	39,0	78,0	-	-	-
75	UCFE215	197	153,0	59,0	20,0	85,8	41,3	23,0	-	-	77,8	33,3	91,5
	EXFE215	197	153,0	59,0	20,0	96,1	41,3	23,0	-	-	92,1	37,3	-
80	UCFE216	197	153,0	61,0	20,0	90,6	41,3	23,0	-	-	82,6	33,3	98,0
	EXFE216	197	153,0	61,0	20,0	99,2	41,3	23,0	-	-	95,2	37,3	-
	UKFE218H	235	187,0	45,0	22,0	65,8	23,8	23,0	42,0	86,0	-	-	-
90	UCFE218	235	187,0	45,0	22,0	80,1	23,8	23,0	-	-	96,0	39,7	111,0
	EXFE218	235	187,0	45,0	22,0	70,3	23,8	23,0	-	-	72,5	24,5	-

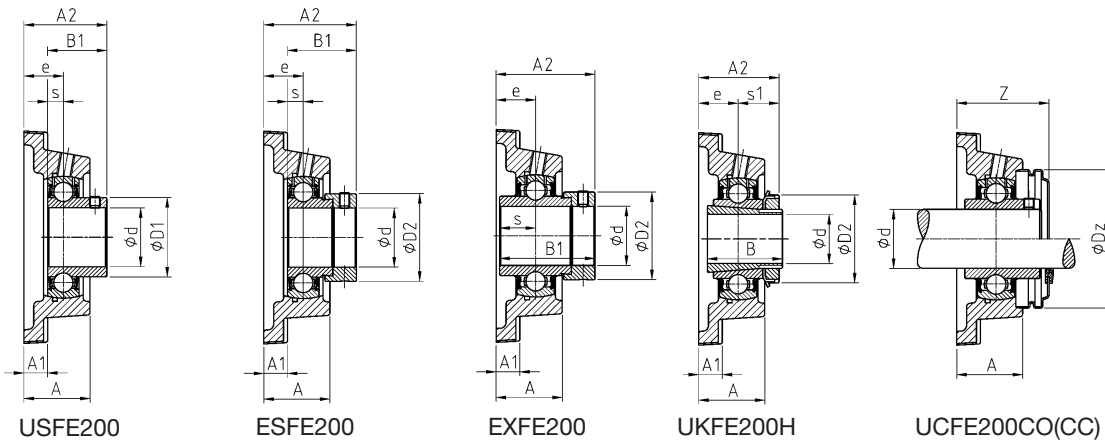

				Gehäuse	Einsatz	Schutzkappe offen *	Schutzkappe geschlossen **	Tragzahl dyn.	Tragzahl stat.	Gewicht	Wellendurch- messer
D2	G	Z	Dz					C _r [kN]	C _{or} [kN]	[kg]	d [mm]
-	R1/8"	58,4	95,0	FE209	UC209	CO	CC	31,85	20,80	2,2	45
-	R1/8"	58,4	95,0	FE209	US209	CO	CC	31,85	20,80	2,2	
63,5	R1/8"	***	***	FE209	ES209	***	***	31,85	20,80	2,2	
63,5	R1/8"	***	***	FE209	EX209	***	***	31,85	20,80	2,4	
70,0	R1/8"	65,8	100,0	FE210	UK210 + H2310	CO	CC	35,10	23,20	2,7	
-	R1/8"	65,8	100,0	FE210	UC210	CO	CC	35,10	23,20	2,6	50
-	R1/8"	65,8	100,0	FE210	US210	CO	CC	35,10	23,20	2,5	
69,9	R1/8"	***	***	FE210	ES210	***	***	35,10	23,20	2,6	
69,9	R1/8"	***	***	FE210	EX210	***	***	35,10	23,20	2,8	
75,0	R1/8"	69,1	110,0	FE211	UK211 + H2311	CO	CC	43,55	29,20	3,7	
-	R1/8"	69,1	110,0	FE211	UC211	CO	CC	43,55	29,20	3,7	55
-	R1/8"	69,1	110,0	FE211	US211	CO	CC	43,55	29,20	3,6	
76,2	R1/8"	***	***	FE211	ES211	***	***	43,55	29,20	3,4	
76,2	R1/8"	***	***	FE211	EX211	***	***	43,55	29,20	3,9	
80,0	R1/8"	78,4	120,0	FE212	UK212 + H2312	CO	CC	52,50	32,80	4,9	
-	R1/8"	78,4	120,0	FE212	UC212	CO	CC	52,50	32,80	4,9	60
-	R1/8"	78,4	120,0	FE212	US212	CO	CC	52,50	32,80	4,7	
84,2	R1/8"	***	***	FE212	ES212	***	***	52,50	32,80	4,6	
84,2	R1/8"	***	***	FE212	EX212	***	***	52,50	32,80	5,2	
85,0	R1/8"	77,4	132,0	FE213	UK213 + H2313	CO	CC	57,20	40,00	6,1	
-	R1/8"	77,4	132,0	FE213	UC213	CO	CC	57,20	40,00	6,0	65
86,0	R1/8"	***	***	FE213	EX213	***	***	57,20	40,00	6,6	
98,0	R1/8"	-	-	FE215	UK215 + H2315	-	-	66,00	49,50	6,9	
-	R1/8"	-	-	FE214	UC214	-	-	62,00	45,00	6,2	70
96,8	R1/8"	-	-	FE214	EX214	-	-	62,00	45,00	6,7	
105,0	R1/8"	-	-	FE216	UK216 + H2316	-	-	72,50	54,20	7,5	
-	R1/8"	-	-	FE215	UC215	-	-	66,00	49,50	6,3	75
102,0	R1/8"	-	-	FE215	EX215	-	-	66,00	49,50	6,9	
-	R1/8"	-	-	FE216	UC216	-	-	72,50	54,20	7,1	80
110,0	R1/8"	-	-	FE216	EX216	-	-	72,50	54,20	7,4	
120,0	R1/8"	-	-	FE218	UK218 + H2318	-	-	96,00	71,50	10,7	
-	R1/8"	-	-	FE218	UC218	-	-	96,00	71,50	10,4	90
120,0	R1/8"	-	-	FE218	EX218	-	-	96,00	71,50	10,9	

* = mit einer offenen Schutzkappe für durchgehende Wellen: Nachsetzzeichen CO wie Bestellbeispiel Seite 6

** = mit einer geschlossenen Schutzkappe für Wellenenden: Nachsetzzeichen CC wie Bestellbeispiel Seite 6

*** = mit Schutzkappen für Einsätze mit Excentering auf Anfrage lieferbar



Gehäuse

F200 nachschmierbar
F300 nachschmierbar

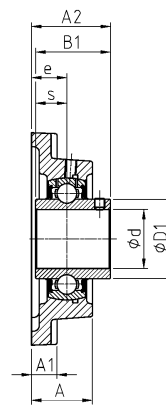
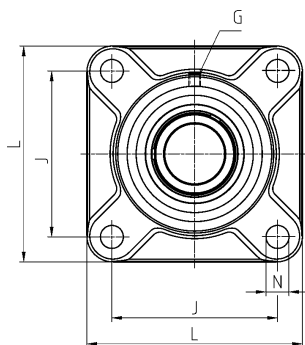
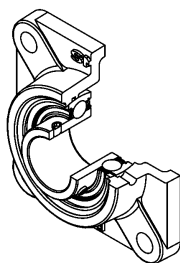

UCF200
UCF300

Wellendurchmesser		Einheit		Hauptabmessungen in mm											
d [mm]		L	J	A	A1	A2	e	N	s1	B	B1	s	D1	D2	
12	UCF201	86	64	25,5	11	33,3	15	12	-	-	31,0	12,7	29,0	-	
	USF201	76	54	25,5	11	31,0	15	12	-	-	22,0	6,0	24,6	-	
	ESF201	76	54	25,5	11	37,1	15	12	-	-	28,6	6,5	-	28,6	
	EXF201	86	64	25,5	11	41,5	15	12	-	-	43,5	17,0	-	33,3	
15	UCF202	86	64	25,5	11	33,3	15	12	-	-	31,0	12,7	29,0	-	
	USF202	76	54	25,5	11	31,0	15	12	-	-	22,0	6,0	24,6	-	
	ESF202	76	54	25,5	11	37,1	15	12	-	-	28,6	6,5	-	28,6	
	EXF202	86	64	25,5	11	41,5	15	12	-	-	43,5	17,0	-	33,3	
17	UCF203	86	64	25,5	11	33,3	15	12	-	-	31,0	12,7	29,0	-	
	USF203	76	54	25,5	11	31,0	15	12	-	-	22,0	6,0	24,6	-	
	ESF203	76	54	25,5	11	37,1	15	12	-	-	28,6	6,5	-	28,6	
	EXF203	86	64	25,5	11	41,5	15	12	-	-	43,5	17,0	-	33,3	
20	UCF204	86	64	25,5	11	33,3	15	12	-	-	31,0	12,7	29,0	-	
	USF204	86	64	25,5	11	33,0	15	12	-	-	25,0	7,0	29,0	-	
	ESF204	86	64	25,5	11	38,4	15	12	-	-	30,9	7,5	-	33,3	
	EXF204	86	64	25,5	11	41,5	15	12	-	-	43,5	17,0	-	33,3	
	UKF205H	95	70	27,0	13	34,5	16	12	18,5	35,0	-	-	-	38,0	
	UKF305H	108	80	29,0	13	37,5	16	16	21,5	35,0	-	-	-	38,0	
25	UCF205	95	70	27,0	13	35,7	16	12	-	-	34,0	14,3	34,0	-	
	USF205	95	70	27,0	13	35,5	16	12	-	-	27,0	7,5	34,0	-	
	ESF205	95	70	27,0	13	39,4	16	12	-	-	30,9	7,5	-	38,1	
	EXF205	95	70	27,0	13	42,9	16	12	-	-	44,3	17,4	-	38,1	
	UKF206H	108	83	31,0	13	38,5	18	12	20,5	38,0	-	-	-	45,0	
	UCF305	108	80	29,0	13	39,0	16	16	-	-	38,0	15,0	35,4	-	
	EXF305	108	80	29,0	13	46,1	16	16	-	-	46,8	16,7	-	42,8	
	UKF306H	125	95	32,0	15	41,0	18	16	23,0	38,0	-	-	-	45,0	
30	UCF206	108	83	31,0	13	40,2	18	12	-	-	38,1	15,9	40,3	-	
	USF206	108	83	31,0	13	40,0	18	12	-	-	30,0	8,0	40,3	-	
	ESF206	108	83	31,0	13	44,7	18	12	-	-	35,7	9,0	-	44,5	
	EXF206	108	83	31,0	13	48,1	18	12	-	-	48,3	18,2	-	44,5	
	UKF207H	117	92	34,0	15	41,5	19	14	22,5	43,0	-	-	-	52,0	
	UCF306	125	95	32,0	15	44,0	18	16	-	-	43,0	17,0	44,6	-	
	EXF306	125	95	32,0	15	50,5	18	16	-	-	50,0	17,5	-	50,0	
	UKF307H	135	100	36,0	16	45,5	20	19	25,5	43,0	-	-	-	52,0	

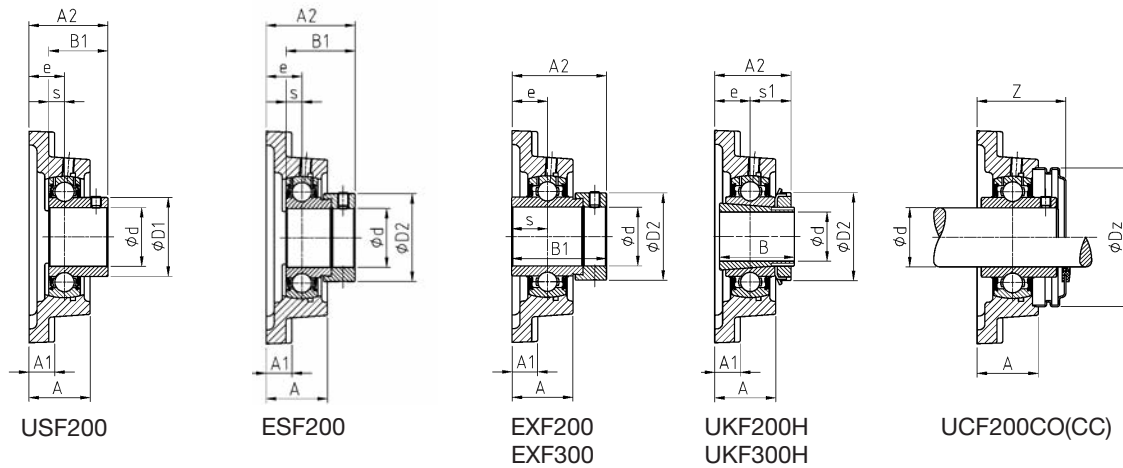

Gehäuse

Einsatz

Schutzkappe
offen *Schutzkappe
geschlossen **Tragzahl
dyn.Tragzahl
stat.

Gewicht

Wellendurch-
messer

G	Z	Dz					C _r [kN]	C _{or} [kN]	[kg]	d [mm]
M6x1	36,6	54,0	F204	UC201	CO	CC	12,80	6,65	0,6	12
M6x1	36,3	46,0	F203	US201	CO	CC	9,55	4,78	0,4	
M6x1	***	***	F203	ES201	***	***	9,55	4,78	0,5	
M6x1	***	***	F204	EX201	***	***	12,80	6,65	0,7	
M6x1	36,6	54,0	F204	UC202	CO	CC	12,80	6,65	0,6	15
M6x1	36,3	46,0	F203	US202	CO	CC	9,55	4,78	0,4	
M6x1	***	***	F203	ES202	***	***	9,55	4,78	0,5	
M6x1	***	***	F204	EX202	***	***	12,80	6,65	0,7	
M6x1	36,6	54,0	F204	UC203	CO	CC	12,80	6,65	0,5	17
M6x1	36,3	46,0	F203	US203	CO	CC	9,55	4,78	0,4	
M6x1	***	***	F203	ES203	***	***	9,55	4,78	0,5	
M6x1	***	***	F204	EX203	***	***	12,80	6,65	0,7	
M6x1	36,6	54,0	F204	UC204	CO	CC	12,80	6,65	0,6	20
M6x1	36,6	54,0	F204	US204	CO	CC	12,80	6,65	0,6	
M6x1	***	***	F204	ES204	***	***	12,80	6,65	0,6	
M6x1	***	***	F204	EX204	***	***	12,80	6,65	0,7	
M6x1	39,2	60,0	F205	UK205 + H2305	CO	CC	14,00	7,88	0,8	25
M6x1	-	-	F305	UK305 + H2305	-	-	22,36	11,50	1,2	
M6x1	39,2	60,0	F205	UC205	CO	CC	14,00	7,88	0,8	
M6x1	39,2	60,0	F205	US205	CO	CC	14,00	7,88	0,8	
M6x1	***	***	F205	ES205	***	***	14,00	7,88	0,8	
M6x1	***	***	F205	EX205	***	***	14,00	7,88	0,9	
M6x1	44,2	70,0	F206	UK206 + H2306	CO	CC	19,50	11,20	1,2	30
M6x1	-	-	F305	UC305	-	-	22,36	11,50	1,1	
M6x1	-	-	F305	EX305	-	-	22,36	11,50	1,2	
M6x1	-	-	F306	UK306 + H2306	-	-	27,00	15,20	1,6	
M6x1	44,2	70,0	F206	UC206	CO	CC	19,50	11,20	1,1	
M6x1	44,2	70,0	F206	US206	CO	CC	19,50	11,20	1,1	
M6x1	***	***	F206	ES206	***	***	19,50	11,20	1,1	
M6x1	***	***	F206	EX206	***	***	19,50	11,20	1,2	
M6x1	48,3	80,0	F207	UK207 + H2307	CO	CC	25,70	15,20	1,6	
M6x1	-	-	F306	UC306	-	-	27,00	15,20	1,6	
M6x1	-	-	F306	EX306	-	-	27,00	15,20	1,7	
M6x1	-	-	F307	UK307 + H2307	-	-	33,50	19,20	2,2	

* = mit einer offenen Schutzkappe für durchgehende Wellen: Nachsetzzeichen CO wie Bestellbeispiel Seite 6

** = mit einer geschlossenen Schutzkappe für Wellenenden: Nachsetzzeichen CC wie Bestellbeispiel Seite 6

*** = mit Schutzkappen für Einsätze mit Excentering auf Anfrage lieferbar

Gehäuse

F200 nachschmierbar
F300 nachschmierbar

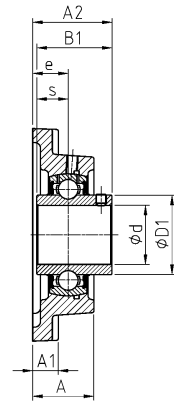
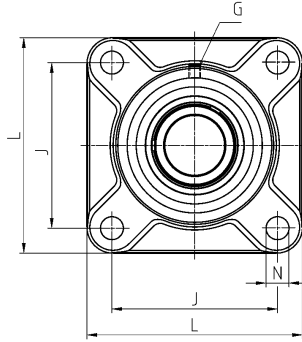
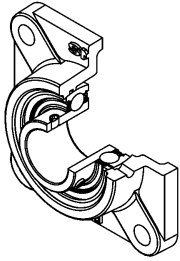

UCF200
UCF300

Wellendurchmesser
Einheit

Hauptabmessungen in mm

d [mm]		L	J	A	A1	A2	e	N	s1	B	B1	s	D1	D2
35	UCF207	117	92	34,0	15	44,4	19	14	-	-	42,9	17,5	48,0	-
	USF207	117	92	34,0	15	42,5	19	14	-	-	32,0	8,5	48,0	-
	ESF207	117	92	34,0	15	48,4	19	14	-	-	38,9	9,5	-	55,6
	EXF207	117	92	34,0	15	51,3	19	14	-	-	51,1	18,8	-	55,6
	UKF208H	130	102	36,0	15	45,5	21	16	24,5	46,0	-	-	-	58,0
	UCF307	135	100	36,0	16	49,0	20	19	-	-	48,0	19,0	48,9	-
	EXF307	135	100	36,0	16	53,3	20	19	-	-	51,6	18,3	-	55,0
	UKF308H	150	112	40,0	17	50,5	23	19	27,5	46,0	-	-	-	58,0
40	UCF208	130	102	36,0	15	51,2	21	16	-	-	49,2	19,0	53,0	-
	USF208	130	102	36,0	15	46,0	21	16	-	-	34,0	9,0	53,0	-
	ESF208	130	102	36,0	15	53,7	21	16	-	-	43,7	11,0	-	60,3
	EXF208	130	102	36,0	15	55,9	21	16	-	-	56,3	21,4	-	60,3
	UKF209H	137	105	38,0	16	48,0	22	16	26,0	50,0	-	-	-	65,0
	UCF308	150	112	40,0	17	56,0	23	19	-	-	52,0	19,0	56,5	-
	EXF308	150	112	40,0	17	60,3	23	19	-	-	57,1	19,8	-	63,5
	UKF309H	160	125	44,0	18	55,0	25	19	30,0	50,0	-	-	-	65,0
45	UCF209	137	105	38,0	16	52,2	22	16	-	-	49,2	19,0	57,2	-
	USF209	137	105	38,0	16	53,0	22	16	-	-	41,2	10,2	57,2	-
	ESF209	137	105	38,0	16	54,7	22	16	-	-	43,7	11,0	-	63,5
	EXF209	137	105	38,0	16	56,9	22	16	-	-	56,3	21,4	-	63,5
	UKF210H	143	111	40,0	16	49,5	22	16	27,5	55,0	-	-	-	70,0
	UCF309	160	125	44,0	18	60,0	25	19	-	-	57,0	22,0	61,8	-
	EXF309	160	125	44,0	18	63,9	25	19	-	-	58,7	19,8	-	70,0
	UKF310H	175	132	48,0	20	60,0	28	23	32,0	55,0	-	-	-	70,0
50	UCF210	143	111	40,0	16	54,6	22	16	-	-	51,6	19,0	61,8	-
	USF210	143	111	40,0	16	54,6	22	16	-	-	43,5	10,9	61,8	-
	ESF210	143	111	40,0	16	54,7	22	16	-	-	43,7	11,0	-	69,9
	EXF210	143	111	40,0	16	60,1	22	16	-	-	62,7	24,6	-	69,9
	UKF211H	162	130	43,0	18	54,0	25	19	29,0	59,0	-	-	-	75,0
	UCF310	175	132	48,0	20	67,0	28	23	-	-	61,0	22,0	68,7	-
	EXF310	175	132	48,0	20	70,0	28	23	-	-	66,6	24,6	-	76,2
	UKF311H	185	140	52,0	20	64,0	30	23	34,0	59,0	-	-	-	75,0

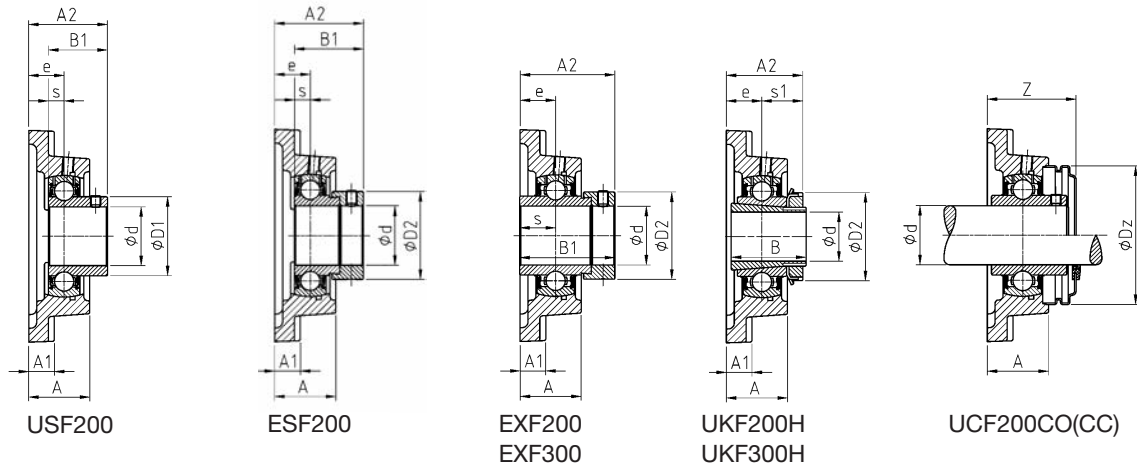

G	Z	Dz	Gehäuse		Einsatz	Schutzkappe offen *		Schutzkappe geschlossen **		Tragzahl dyn.	Tragzahl stat.	Gewicht [kg]	Wellendurch- messer [mm]
			F	UC		CO	CC	C _r [kN]	C _{or} [kN]				
M6x1	48,3	80,0	F207	UC207	CO	CC	25,70	15,20	1,5	35			
M6x1	48,3	80,0	F207	US207	CO	CC	25,70	15,20	1,5				
M6x1	***	***	F207	ES207	***	***	25,70	15,20	1,5				
M6x1	***	***	F207	EX207	***	***	25,70	15,20	1,6				
M6x1	55,2	88,0	F208	UK208 + H2308	CO	CC	29,60	18,20	2,0				
M6x1	-	-	F307	UC307	-	-	33,50	19,20	2,0				
M6x1	-	-	F307	EX307	-	-	33,50	19,20	2,1				
M6x1	-	-	F308	UK308 + H2308	-	-	40,56	24,00	2,8				
M6x1	55,2	88,0	F208	UC208	CO	CC	29,60	18,20	1,9	40			
M6x1	55,2	88,0	F208	US208	CO	CC	29,60	18,20	1,9				
M6x1	***	***	F208	ES208	***	***	29,60	18,20	1,9				
M6x1	***	***	F208	EX208	***	***	29,60	18,20	2,1				
M6x1	56,3	95,0	F209	UK209 + H2309	CO	CC	31,85	20,80	2,3				
M6x1	-	-	F308	UC308	-	-	40,56	24,00	2,7				
M6x1	-	-	F308	EX308	-	-	40,56	24,00	2,8				
M6x1	-	-	F309	UK309 + H2309	-	-	53,00	31,80	3,5				
M6x1	56,3	95,0	F209	UC209	CO	CC	31,85	20,80	2,1	45			
M6x1	56,3	95,0	F209	US209	CO	CC	31,85	20,80	2,1				
M6x1	***	***	F209	ES209	***	***	31,85	20,80	2,1				
M6x1	***	***	F209	EX209	***	***	31,85	20,80	2,3				
M6x1	59,3	100,0	F210	UK210 + H2310	CO	CC	35,10	23,20	2,7				
M6x1	-	-	F309	UC309	-	-	53,00	31,80	3,3				
M6x1	-	-	F309	EX309	-	-	53,00	31,80	3,5				
M6x1	-	-	F310	UK310 + H2310	-	-	62,00	37,80	4,5				
M6x1	59,3	100,0	F210	UC210	CO	CC	35,10	23,20	2,5	50			
M6x1	59,3	100,0	F210	US210	CO	CC	35,10	23,20	2,5				
M6x1	***	***	F210	ES210	***	***	35,10	23,20	2,5				
M6x1	***	***	F210	EX210	***	***	35,10	23,20	2,7				
M6x1	62,8	110,0	F211	UK211 + H2311	CO	CC	43,55	29,20	3,4				
M6x1	-	-	F310	UC310	-	-	62,00	37,80	4,4				
M6x1	-	-	F310	EX310	-	-	62,00	37,80	4,6				
M6x1	-	-	F311	UK311 + H2311	-	-	71,50	44,80	5,5				

* = mit einer offenen Schutzkappe für durchgehende Wellen: Nachsetzzeichen CO wie Bestellbeispiel Seite 6

** = mit einer geschlossenen Schutzkappe für Wellenenden: Nachsetzzeichen CC wie Bestellbeispiel Seite 6

*** = mit Schutzkappen für Einsätze mit Excenterring auf Anfrage lieferbar



Gehäuse

F200 nachschmierbar
F300 nachschmierbar

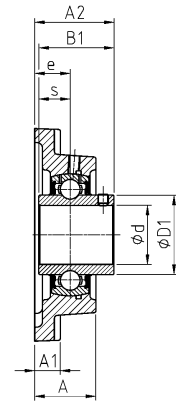
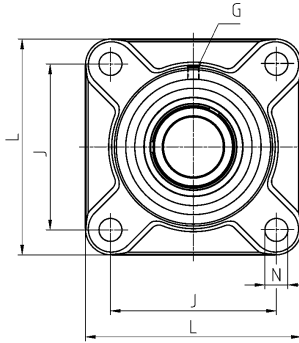
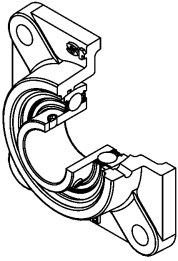

UCF200
UCF300

Wellendurchmesser
Einheit

Hauptabmessungen in mm

d [mm]		L	J	A	A1	A2	e	N	s1	B	B1	s	D1	D2
55	UCF211	162	130	43,0	18	58,4	25	19	-	-	55,6	22,2	69,0	-
	USF211	162	130	43,0	18	58,5	25	19	-	-	45,3	11,8	69,0	-
	ESF211	162	130	43,0	18	61,4	25	19	-	-	48,4	12,0	-	76,2
	EXF211	162	130	43,0	18	68,6	25	19	-	-	71,3	27,7	-	76,2
	UKF212H	175	143	48,0	18	60,0	29	19	31,0	62,0	-	-	-	80,0
	UCF311	185	140	52,0	20	71,0	30	23	-	-	66,0	25,0	74,9	-
	EXF311	185	140	52,0	20	75,2	30	23	-	-	73,0	27,8	-	83,0
	UKF312H	193	150	56,0	22	69,5	33	23	36,5	62,0	-	-	-	80,0
60	UCF212	175	143	48,0	18	68,7	29	19	-	-	65,1	25,4	74,9	-
	USF212	175	143	48,0	18	67,8	29	19	-	-	53,7	14,9	74,9	-
	ESF212	175	143	48,0	18	66,3	29	19	-	-	49,3	12,0	-	84,2
	EXF212	175	143	48,0	18	75,8	29	19	-	-	77,7	30,9	-	84,2
	UKF213H	187	149	50,0	22	62,0	30	19	32,0	65,0	-	-	-	85,0
	UCF312	193	150	56,0	22	78,0	33	23	-	-	71,0	26,0	81,0	-
	EXF312	193	150	56,0	22	81,5	33	23	-	-	79,4	31,0	-	89,0
	UKF313H	208	166	58,0	22	71,5	33	23	38,5	65,0	-	-	-	85,0
65	UCF213	187	149	50,0	22	69,7	30	19	-	-	65,1	25,4	82,0	-
	EXF213	187	149	50,0	22	81,6	30	19	-	-	85,7	34,1	-	86,0
	UKF215H	200	159	56,0	22	69,5	34	19	35,5	73,0	-	-	-	98,0
	UCF313	208	166	58,0	22	78,0	33	23	-	-	75,0	30,0	87,5	-
	EXF313	208	166	58,0	22	86,2	33	23	-	-	85,7	32,5	-	97,0
	UKF315H	236	184	66,0	25	81,5	39	25	42,5	73,0	-	-	-	98,0
70	UCF214	193	152	54,0	22	75,4	31	19	-	-	74,6	30,2	86,5	-
	EXF214	193	152	54,0	22	82,6	31	19	-	-	85,7	34,1	-	96,8
	UKF216H	208	165	57,0	22	73,0	34	23	39,0	78,0	-	-	-	105,0
	UCF314	226	178	61,0	25	83,0	36	25	-	-	78,0	33,0	94,0	-
	EXF314	226	178	61,0	25	94,0	36	25	-	-	92,1	34,2	-	102,0
	UKF316H	250	196	68,0	27	82,5	38	31	44,5	78,0	-	-	-	105,0
75	UCF215	200	159	56,0	22	78,5	34	19	-	-	77,8	33,3	91,5	-
	EXF215	200	159	56,0	22	88,8	34	19	-	-	92,1	37,3	-	102,0
	UKF217H	220	175	63,0	24	76,0	36	23	40,0	82,0	-	-	-	110,0
	UCF315	236	184	66,0	25	89,0	39	25	-	-	82,0	32,0	100,5	-
	EXF315	236	184	66,0	25	101,7	39	25	-	-	100,0	37,3	-	113,0
	UKF317H	260	204	74,0	27	92,0	44	31	48,0	82,0	-	-	-	110,0

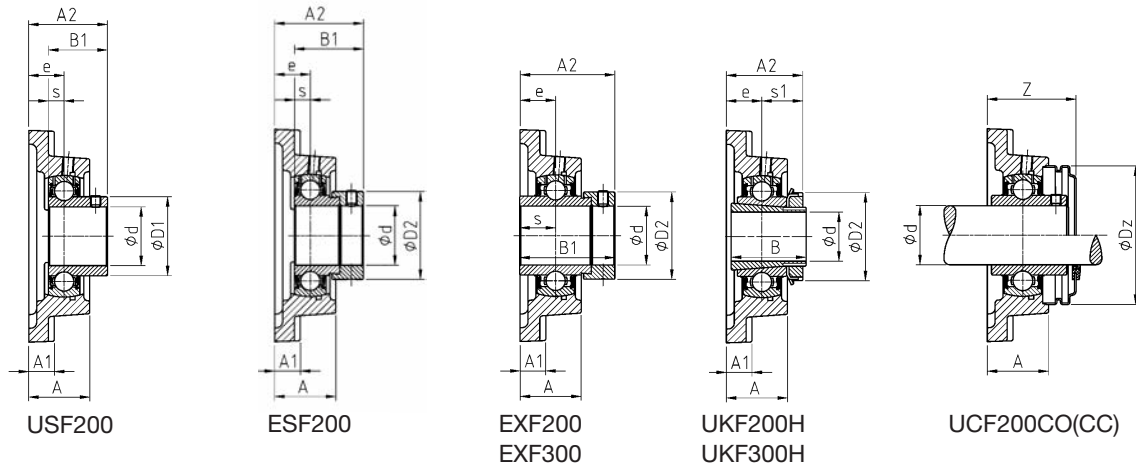

			Gehäuse	Einsatz	Schutzkappe offen *	Schutzkappe geschlossen **	Tragzahl dyn.	Tragzahl stat.	Gewicht	Wellendurch- messer
G	Z	Dz					C_r [kN]	C_{or} [kN]	[kg]	d [mm]
M6x1	62,8	110,0	F211	UC211	CO	CC	43,55	29,20	3,4	55
M6x1	62,8	110,0	F211	US211	CO	CC	43,55	29,20	3,3	
M6x1	***	***	F211	ES211	***	***	43,55	29,20	3,1	
M6x1	***	***	F211	EX211	***	***	43,55	29,20	3,6	
M6x1	73,2	120,0	F212	UK212 + H2312	CO	CC	52,50	32,80	4,4	60
M6x1	-	-	F311	UC311	-	-	71,50	44,80	5,2	
M6x1	-	-	F311	EX311	-	-	71,50	44,80	5,6	
M6x1	-	-	F312	UK312 + H2312	-	-	81,60	51,80	6,3	
M6x1	73,2	120,0	F212	UC212	CO	CC	52,50	32,80	4,4	65
M6x1	73,2	120,0	F212	US212	CO	CC	52,50	32,80	4,2	
M6x1	***	***	F212	ES212	***	***	52,50	32,80	4,1	
M6x1	***	***	F212	EX212	***	***	52,50	32,80	4,8	
M6x1	74,3	132,0	F213	UK213 + H2313	CO	CC	57,20	40,00	5,6	70
M6x1	-	-	F312	UC312	-	-	81,60	51,80	6,4	
M6x1	-	-	F312	EX312	-	-	81,60	51,80	6,7	
M6x1	-	-	F313	UK313 + H2313	-	-	93,86	60,50	7,9	
M6x1	74,3	132,0	F213	UC213	CO	CC	57,20	40,00	5,6	75
M6x1	***	***	F213	EX213	***	***	57,20	40,00	6,1	
M10x1	-	-	F215	UK215 + H2315	-	-	66,00	49,50	6,4	
M6x1	-	-	F313	UC313	-	-	93,86	60,50	7,9	
M6x1	-	-	F313	EX313	-	-	93,86	60,50	8,3	70
M10x1	-	-	F315	UK315 + H2315	-	-	113,36	76,80	11,1	
M10x1	-	-	F214	UC214	-	-	62,00	45,00	6,3	
M10x1	-	-	F214	EX214	-	-	62,00	45,00	6,8	
M10x1	-	-	F216	UK216 + H2316	-	-	72,50	54,20	7,4	75
M10x1	-	-	F314	UC314	-	-	104,26	68,00	9,5	
M10x1	-	-	F314	EX314	-	-	104,26	68,00	10,0	
M10x1	-	-	F316	UK316 + H2316	-	-	122,85	86,50	13,0	
M10x1	-	-	F215	UC215	-	-	66,00	49,50	5,8	75
M10x1	-	-	F215	EX215	-	-	66,00	49,50	6,5	
M10x1	-	-	F217	UK217 + H2317	-	-	83,20	63,80	9,2	
M10x1	-	-	F315	UC315	-	-	113,36	76,80	10,4	
M10x1	-	-	F315	EX315	-	-	113,36	76,80	11,4	75
M10x1	-	-	F317	UK317 + H2317	-	-	132,60	96,50	15,7	

* = mit einer offenen Schutzkappe für durchgehende Wellen: Nachsetzzeichen CO wie Bestellbeispiel Seite 6

** = mit einer geschlossenen Schutzkappe für Wellenenden: Nachsetzzeichen CC wie Bestellbeispiel Seite 6

*** = mit Schutzkappen für Einsätze mit Excenterring auf Anfrage lieferbar

Gehäuse

F200 nachschmierbar
F300 nachschmierbar

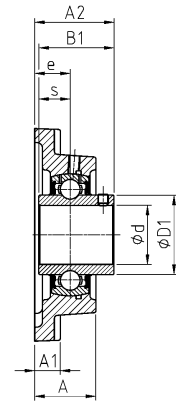
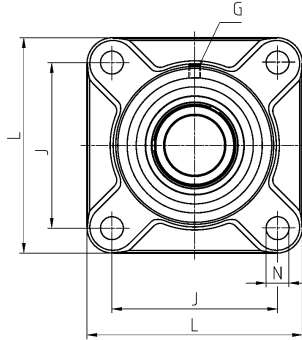
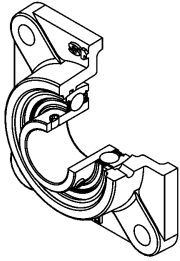

UCF200
UCF300

Wellendurchmesser
Einheit

Hauptabmessungen in mm

d [mm]		L	J	A	A1	A2	e	N	s1	B	B1	s	D1	D2
80	UCF216	208	165	57,0	22	83,3	34	23	-	-	82,6	33,3	98,0	-
	EXF216	208	165	57,0	22	91,9	34	23	-	-	95,2	37,3	-	110,0
	UKF218H	235	187	68,0	25	82,0	40	23	42,0	86,0	-	-	-	120,0
	UCF316	250	196	68,0	27	90,0	38	31	-	-	86,0	34,0	107,9	-
	EXF316	250	196	68,0	27	103,9	38	31	-	-	106,4	40,5	-	119,0
	UKF318H	280	216	76,0	30	92,0	44	35	48,0	86,0	-	-	-	120,0
85	UCF217	220	175	63,0	24	87,6	36	23	-	-	85,7	34,1	105,1	-
	EXF217	220	175	63,0	24	83,6	36	23	-	-	73,2	23,4	-	119,0
	UCF317	260	204	74,0	27	100,0	44	31	-	-	96,0	40,0	114,0	-
	EXF317	260	204	74,0	27	111,5	44	31	-	-	109,5	42,0	-	127,0
	UKF319H	290	228	94,0	30	111,0	59	35	52,0	90,0	-	-	-	125,0
90	UCF218	235	187	68,0	25	96,3	40	23	-	-	96,0	39,7	111,0	-
	EXF218	235	187	68,0	25	86,5	40	23	-	-	72,5	24,5	-	120,0
	UCF318	280	216	76,0	30	100,0	44	35	-	-	96,0	40,0	120,0	-
	EXF318	280	216	76,0	30	116,3	44	35	-	-	115,9	43,6	-	133,0
	UKF320H	310	242	94,0	32	113,0	59	38	54,0	97,0	-	-	-	130,0
95	UCF319	290	228	94,0	30	121,0	59	35	-	-	103,0	41,0	126,5	-
	EXF319	290	228	94,0	30	134,5	59	35	-	-	122,3	46,8	-	140,0
100	UCF320	310	242	94,0	32	125,0	59	38	-	-	108,0	42,0	134,5	-
	EXF320	310	242	94,0	32	137,6	59	38	-	-	128,6	50,0	-	146,0
	UKF322H	340	266	96,0	35	121,0	60	41	61,0	105,0	-	-	-	145,0
105	UCF321	310	242	94,0	32	127,0	59	38	-	-	112,0	44,0	140,5	-
110	UCF322	340	266	96,0	35	131,0	60	41	-	-	117,0	46,0	149,0	-
	UKF324H	370	290	110,0	40	130,0	65	41	65,0	112,0	-	-	-	155,0
115	UKF326H	410	320	115,0	45	134,0	65	41	69,0	121,0	-	-	-	165,0
120	UCF324	370	290	110,0	40	140,0	65	41	-	-	126,0	51,0	163,0	-
125	UKF328H	450	350	125,0	55	148,0	75	41	73,0	131,0	-	-	-	180,0
130	UCF326	410	320	115,0	45	146,0	65	41	-	-	135,0	54,0	177,0	-
140	UCF328	450	350	125,0	55	161,0	75	41	-	-	145,0	59,0	190,0	-

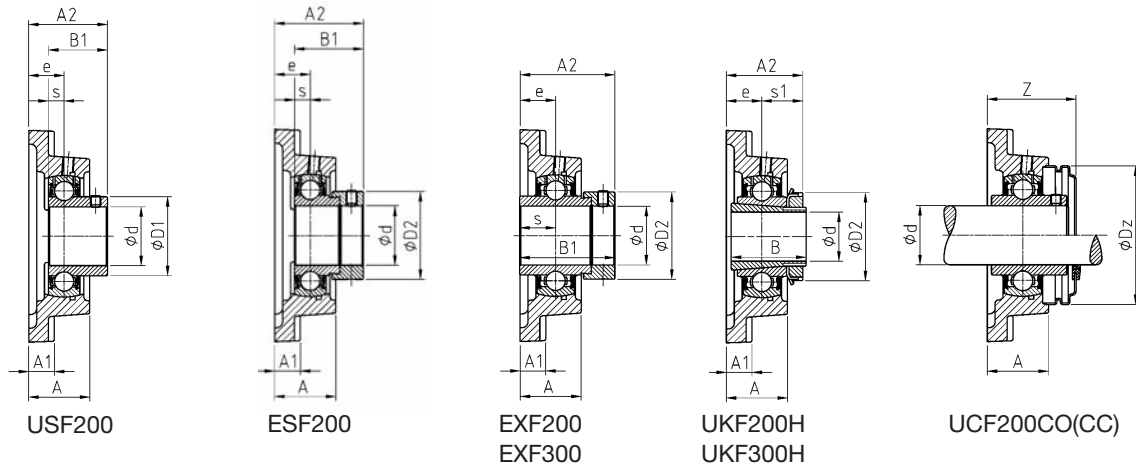

			Gehäuse	Einsatz	Schutzkappe offen *	Schutzkappe geschlossen **	Tragzahl dyn.	Tragzahl stat.	Gewicht	Wellendurch- messer
G	Z	Dz					C _r [kN]	C _{or} [kN]	[kg]	d [mm]
M10x1	-	-	F216	UC216	-	-	72,50	54,20	7,0	80
M10x1	-	-	F216	EX216	-	-	72,50	54,20	7,3	80
M10x1	-	-	F218	UK218 + H2318	-	-	96,00	71,50	11,8	80
M10x1	-	-	F316	UC316	-	-	122,85	86,50	12,8	80
M10x1	-	-	F316	EX316	-	-	122,85	86,50	13,9	80
M10x1	-	-	F318	UK318 + H2318	-	-	143,00	108,00	18,1	80
M10x1	-	-	F217	UC217	-	-	83,20	63,80	8,8	85
M10x1	-	-	F217	EX217	-	-	83,20	63,80	9,1	85
M10x1	-	-	F317	UC317	-	-	132,60	96,50	15,7	85
M10x1	-	-	F317	EX317	-	-	132,60	96,50	16,8	85
M10x1	-	-	F319	UK319 + H2319	-	-	156,00	122,00	21,6	85
M10x1	-	-	F218	UC218	-	-	96,00	71,50	11,6	90
M10x1	-	-	F218	EX218	-	-	96,00	71,50	12,1	90
M10x1	-	-	F318	UC318	-	-	143,00	108,00	18,1	90
M10x1	-	-	F318	EX318	-	-	143,00	108,00	19,3	90
M10x1	-	-	F320	UK320 + H2320	-	-	171,60	140,00	25,6	90
M10x1	-	-	F319	UC319	-	-	156,00	122,00	21,3	95
M10x1	-	-	F319	EX319	-	-	156,00	122,00	22,8	95
M10x1	-	-	F320	UC320	-	-	171,60	140,00	25,8	100
M10x1	-	-	F320	EX320	-	-	171,60	140,00	27,6	100
M10x1	-	-	F322	UK322 + H2322	-	-	205,00	178,00	42,6	100
M10x1	-	-	F321	UC321	-	-	182,00	155,00	30,2	105
M10x1	-	-	F322	UC322	-	-	205,00	178,00	39,3	110
M10x1	-	-	F324	UK324 + H2324	-	-	228,00	208,00	51,9	110
M10x1	-	-	F326	UK326 + H2326	-	-	252,00	242,00	68,5	115
M10x1	-	-	F324	UC324	-	-	228,00	208,00	49,2	120
M10x1	-	-	F328	UK328 + H2328	-	-	275,00	272,00	90,7	125
M10x1	-	-	F326	UC326	-	-	252,00	242,00	63,6	130
M10x1	-	-	F328	UC328	-	-	275,00	272,00	84,7	140

* = mit einer offenen Schutzkappe für durchgehende Wellen: Nachsetzezeichen CO wie Bestellbeispiel Seite 6

** = mit einer geschlossenen Schutzkappe für Wellenenden: Nachsetzezeichen CC wie Bestellbeispiel Seite 6

*** = mit Schutzkappen für Einsätze mit Excentring auf Anfrage lieferbar

Gehäuse FCE200 nachschmierbar

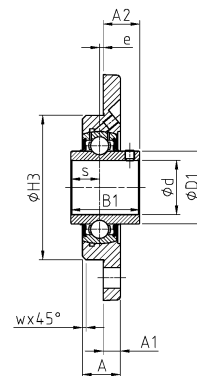
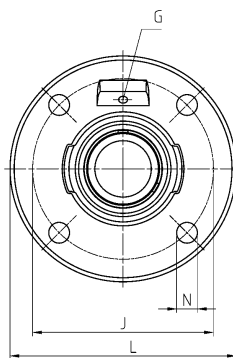
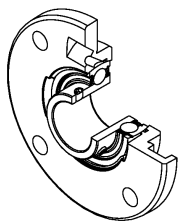

UCFCE200

Wellendurchmesser		Einheit		Hauptabmessungen in mm									
d [mm]		L	J	A	A1	A2	W	H3	e	N	s1	B	B1
12	UCFCE201	100	78	18,0	8,0	16,3	2	62	2,0	9,0	-	-	31,0
	USFCE201	100	78	18,0	8,0	14,0	2	62	2,0	9,0	-	-	22,0
	ESFCE201	100	78	18,0	8,0	20,1	2	62	2,0	9,0	-	-	28,6
	EXFCE201	100	78	18,0	8,0	24,5	2	62	2,0	9,0	-	-	43,5
15	UCFCE202	100	78	18,0	8,0	16,3	2	62	2,0	9,0	-	-	31,0
	USFCE202	100	78	18,0	8,0	14,0	2	62	2,0	9,0	-	-	22,0
	ESFCE202	100	78	18,0	8,0	20,1	2	62	2,0	9,0	-	-	28,6
	EXFCE202	100	78	18,0	8,0	24,5	2	62	2,0	9,0	-	-	43,5
17	UCFCE203	100	78	18,0	8,0	16,3	2	62	2,0	9,0	-	-	31,0
	USFCE203	100	78	18,0	8,0	14,0	2	62	2,0	9,0	-	-	22,0
	ESFCE203	100	78	18,0	8,0	20,1	2	62	2,0	9,0	-	-	28,6
	EXFCE203	100	78	18,0	8,0	24,5	2	62	2,0	9,0	-	-	43,5
20	UCFCE204	100	78	18,0	8,0	16,3	2	62	2,0	9,0	-	-	31,0
	USFCE204	100	78	18,0	8,0	16,0	2	62	2,0	9,0	-	-	25,0
	ESFCE204	100	78	18,0	8,0	21,4	2	62	2,0	9,0	-	-	30,9
	EXFCE204	100	78	18,0	8,0	24,5	2	62	2,0	9,0	-	-	43,5
	UKFCE205H	115	90	20,0	9,0	21,0	2	70	2,5	9,0	18,5	35,0	-
25	UCFCE205	115	90	20,0	9,0	17,2	2	70	2,5	9,0	-	-	34,0
	USFCE205	115	90	20,0	9,0	17,0	2	70	2,5	9,0	-	-	27,0
	ESFCE205	115	90	20,0	9,0	20,9	2	70	2,5	9,0	-	-	30,9
	EXFCE205	115	90	20,0	9,0	24,4	2	70	2,5	9,0	-	-	44,3
	UKFCE206H	125	100	21,0	9,5	22,5	2	80	2,0	11,5	20,5	38,0	-
30	UCFCE206	125	100	21,0	9,5	20,2	2	80	2,0	11,5	-	-	38,1
	USFCE206	125	100	21,0	9,5	20,0	2	80	2,0	11,5	-	-	30,0
	ESFCE206	125	100	21,0	9,5	24,7	2	80	2,0	11,5	-	-	35,7
	EXFCE206	125	100	21,0	9,5	28,1	2	80	2,0	11,5	-	-	48,3
	UKFCE207H	135	110	21,0	10,0	23,5	2	90	1,0	11,5	22,5	43,0	-
35	UCFCE207	135	110	21,0	10,0	24,4	2	90	1,0	11,5	-	-	42,9
	USFCE207	135	110	21,0	10,0	22,5	2	90	1,0	11,5	-	-	32,0
	ESFCE207	135	110	21,0	10,0	28,4	2	90	1,0	11,5	-	-	38,9
	EXFCE207	135	110	21,0	10,0	31,3	2	90	1,0	11,5	-	-	51,1
	UKFCE208H	145	120	23,0	11,5	25,5	2	100	1,0	11,5	24,5	46,0	-
40	UCFCE208	145	120	23,0	11,5	29,2	2	100	1,0	11,5	-	-	49,2
	USFCE208	145	120	23,0	11,5	24,0	2	100	1,0	11,5	-	-	34,0
	ESFCE208	145	120	23,0	11,5	31,7	2	100	1,0	11,5	-	-	43,7
	EXFCE208	145	120	23,0	11,5	33,9	2	100	1,0	11,5	-	-	56,3
	UKFCE209H	155	130	25,0	12,0	28,0	2	105	2,0	14,0	26,0	50,0	-

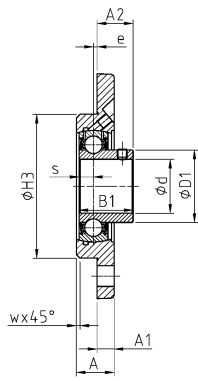

USFCE200

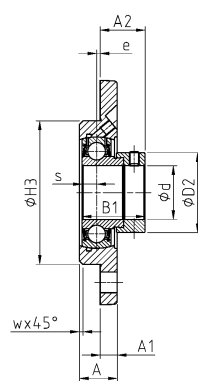

ESFCE200

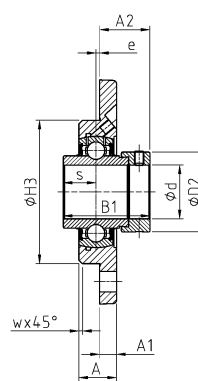

EXFCE200

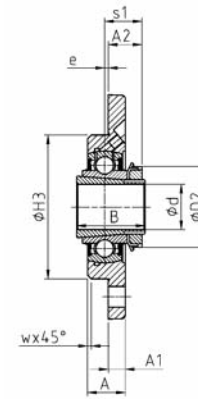

UKFCE200H

				Gehäuse	Einsatz	Tragzahl dyn.	Tragzahl stat.	Gewicht	Wellendurchmesser
s	D1	D2	G			C _r [kN]	C _{0r} [kN]	[kg]	d [mm]
12,7	29,0	-	M6x1	FCE204	UC201	12,80	6,65	0,6	12
6,0	24,6	-	M6x1	FCE203	US201	9,55	4,78	0,5	
6,5	-	28,6	M6x1	FCE203	ES201	9,55	4,78	0,5	
17,0	-	33,3	M6x1	FCE204	EX201	12,80	6,65	0,7	
12,7	29,0	-	M6x1	FCE204	UC202	12,80	6,65	0,6	15
6,0	24,6	-	M6x1	FCE203	US202	9,55	4,78	0,5	
6,5	-	28,6	M6x1	FCE203	ES202	9,55	4,78	0,5	
17,0	-	33,3	M6x1	FCE204	EX202	12,80	6,65	0,6	
12,7	29,0	-	M6x1	FCE204	UC203	12,80	6,65	0,6	17
6,0	24,6	-	M6x1	FCE203	US203	9,55	4,78	0,5	
6,5	-	28,6	M6x1	FCE203	ES203	9,55	4,78	0,5	
17,0	-	33,3	M6x1	FCE204	EX203	12,80	6,65	0,6	
12,7	29,0	-	M6x1	FCE204	UC204	12,80	6,65	0,5	20
7,0	29,0	-	M6x1	FCE204	US204	12,80	6,65	0,5	
7,5	-	33,3	M6x1	FCE204	ES204	12,80	6,65	0,5	
17,0	-	33,3	M6x1	FCE204	EX204	12,80	6,65	0,6	
-	-	38,0	M6x1	FCE205	UK205 + H2305	14,00	7,88	0,8	
14,3	34,0	-	M6x1	FCE205	UC205	14,00	7,88	0,8	25
7,5	34,0	-	M6x1	FCE205	US205	14,00	7,88	0,8	
7,5	-	38,1	M6x1	FCE205	ES205	14,00	7,88	0,8	
17,4	-	38,1	M6x1	FCE205	EX205	14,00	7,88	0,8	
-	-	45,0	M6x1	FCE206	UK206 + H2306	19,50	11,20	1,0	
15,9	40,3	-	M6x1	FCE206	UC206	19,50	11,20	1,0	30
8,0	40,3	-	M6x1	FCE206	US206	19,50	11,20	0,9	
9,0	-	44,5	M6x1	FCE206	ES206	19,50	11,20	1,0	
18,2	-	44,5	M6x1	FCE206	EX206	19,50	11,20	1,1	
-	-	52,0	M6x1	FCE207	UK207 + H2307	25,70	15,20	1,3	
17,5	48,0	-	M6x1	FCE207	UC207	25,70	15,20	1,2	35
8,5	48,0	-	M6x1	FCE207	US207	25,70	15,20	1,2	
9,5	-	55,6	M6x1	FCE207	ES207	25,70	15,20	1,3	
18,8	-	55,6	M6x1	FCE207	EX207	25,70	15,20	1,4	
-	-	58,0	M6x1	FCE208	UK208 + H2308	29,60	18,20	1,7	
19,0	53,0	-	M6x1	FCE208	UC208	29,60	18,20	1,6	40
9,0	53,0	-	M6x1	FCE208	US208	29,60	18,20	1,6	
11,0	-	60,3	M6x1	FCE208	ES208	29,60	18,20	1,7	
21,4	-	60,3	M6x1	FCE208	EX208	29,60	18,20	1,8	
-	-	65,0	M6x1	FCE209	UK209 + H2309	31,85	20,80	2,0	



Gehäuse FCE200 nachschmierbar

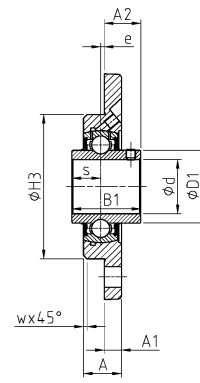
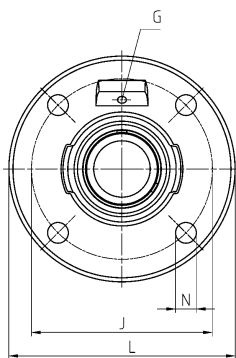
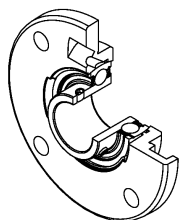

UCFCE200

Wellendurchmesser
Einheit

Hauptabmessungen in mm

d [mm]		L	J	A	A1	A2	W	H3 h8	e	N	s1	B	B1
45	UCFCE209	155	130	25,0	12,0	28,2	2	105	2,0	14,0	-	-	49,2
	USFCE209	155	130	25,0	12,0	29,0	2	105	2,0	14,0	-	-	41,2
	ESFCE209	155	130	25,0	12,0	30,7	2	105	2,0	14,0	-	-	43,7
	EXFCE209	155	130	25,0	12,0	32,9	2	105	2,0	14,0	-	-	56,3
	UKFCE210H	165	135	25,5	13,0	28,5	3	110	1,0	14,0	27,5	55,0	-
50	UCFCE210	165	135	25,5	13,0	31,6	3	110	1,0	14,0	-	-	51,6
	USFCE210	165	135	25,5	13,0	31,6	3	110	1,0	14,0	-	-	43,5
	ESFCE210	165	135	25,5	13,0	31,7	3	110	1,0	14,0	-	-	43,7
	EXFCE210	165	135	25,5	13,0	37,1	3	110	1,0	14,0	-	-	62,7
	UKFCE211H	185	150	27,5	15,0	29,0	3	125	0,0	18,0	29,0	59,0	-
55	UCFCE211	185	150	27,5	15,0	33,4	3	125	0,0	18,0	-	-	55,6
	USFCE211	185	150	27,5	15,0	33,5	3	125	0,0	18,0	-	-	45,3
	ESFCE211	185	150	27,5	15,0	36,4	3	125	0,0	18,0	-	-	48,4
	EXFCE211	185	150	27,5	15,0	43,6	3	125	0,0	18,0	-	-	71,3
	UKFCE212H	195	160	30,5	16,0	32,0	3	135	1,0	18,0	31,0	62,0	-
60	UCFCE212	195	160	30,5	16,0	38,7	3	135	1,0	18,0	-	-	65,1
	USFCE212	195	160	30,5	16,0	37,8	3	135	1,0	18,0	-	-	53,7
	ESFCE212	195	160	30,5	16,0	36,3	3	135	1,0	18,0	-	-	49,3
	EXFCE212	195	160	30,5	16,0	45,8	3	135	1,0	18,0	-	-	77,7
	UKFCE213H	215	177	33,0	18,0	32,0	6	150	0,0	18,0	32,0	65,0	-
65	UCFCE213	215	177	33,0	18,0	39,7	6	150	0,0	18,0	-	-	65,1
	EXFCE213	215	177	33,0	18,0	51,6	6	150	0,0	18,0	-	-	85,7
	UKFCE215H	215	177	33,0	18,0	35,5	6	150	0,0	18,0	35,5	73,0	-
70	UCFCE214	215	177	33,0	18,0	44,4	6	150	0,0	18,0	-	-	74,6
	EXFCE214	215	177	33,0	18,0	51,6	6	150	0,0	18,0	-	-	85,7
	UKFCE216H	220	184	33,0	18,5	37,0	6	160	-2,0	18,0	39,0	78,0	-
75	UCFCE215	220	184	33,0	18,0	44,5	6	160	0,0	18,0	-	-	77,8
	EXFCE215	220	184	33,0	18,0	54,8	6	160	0,0	18,0	-	-	92,1
80	UCFCE216	220	184	33,0	18,5	51,3	6	160	-2,0	18,0	-	-	82,6
	EXFCE216	220	184	33,0	18,5	59,9	6	160	-2,0	18,0	-	-	95,2
	UKFCE218H	265	220	37,0	22,5	38,0	3	190	-4,0	23,0	42,0	86,0	-
90	UCFCE218	265	220	37,0	22,5	60,3	3	190	-4,0	23,0	-	-	96,0
	EXFCE218	265	220	37,0	22,5	50,5	3	190	-4,0	23,0	-	-	72,5

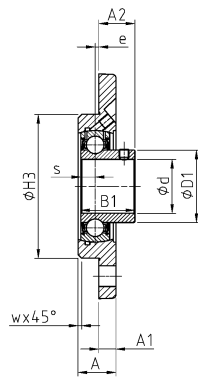

USFCE200

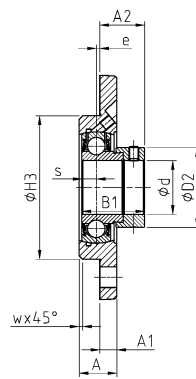

ESFCE200

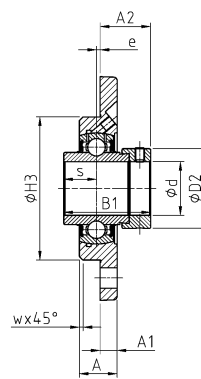

EXFCE200

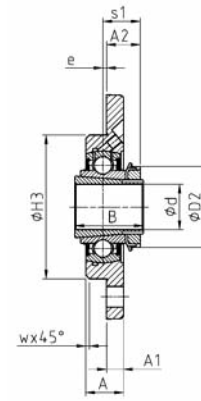

UKFCE200H

s	D1	D2	G	Gehäuse	Einsatz	Tragzahl dyn.	Tragzahl stat.	Gewicht	Wellendurch- messer
						C_r [kN]	C_{or} [kN]	[kg]	d [mm]
19,0	57,2	-	M6x1	FCE209	UC209	31,85	20,80	1,9	45
10,2	57,2	-	M6x1	FCE209	US209	31,85	20,80	1,8	
11,0	-	63,5	M6x1	FCE209	ES209	31,85	20,80	1,9	
21,4	-	63,5	M6x1	FCE209	EX209	31,85	20,80	2,1	
-	-	70,0	M8x1	FCE210	UK210 + H2310	35,10	23,20	2,4	50
19,0	61,8	-	M8x1	FCE210	UC210	35,10	23,20	2,2	
10,9	61,8	-	M8x1	FCE210	US210	35,10	23,20	2,2	
11,0	-	69,9	M8x1	FCE210	ES210	35,10	23,20	2,2	
24,6	-	69,9	M8x1	FCE210	EX210	35,10	23,20	2,4	
-	-	75,0	M6x1	FCE211	UK211 + H2311	43,55	29,20	3,2	55
22,2	69,0	-	M6x1	FCE211	UC211	43,55	29,20	3,1	
11,8	69,0	-	M6x1	FCE211	US211	43,55	29,20	3,1	
12,0	-	76,2	M6x1	FCE211	ES211	43,55	29,20	2,9	
27,7	-	76,2	M6x1	FCE211	EX211	43,55	29,20	3,4	
-	-	80,0	R1/8"	FCE212	UK212 + H2312	52,50	32,80	3,9	60
25,4	74,9	-	R1/8"	FCE212	UC212	52,50	32,80	3,9	
14,9	74,9	-	R1/8"	FCE212	US212	52,50	32,80	3,7	
12,0	-	84,2	R1/8"	FCE212	ES212	52,50	32,80	3,6	
30,9	-	84,2	R1/8"	FCE212	EX212	52,50	32,80	4,2	
-	-	85,0	R1/8"	FCE213	UK213 + H2313	57,20	40,00	5,0	65
25,4	82,0	-	R1/8"	FCE213	UC213	57,20	40,00	4,9	
34,1	-	86,0	R1/8"	FCE213	EX213	57,20	40,00	5,5	
-	-	98,0	R1/8"	FCE215	UK215 + H2315	66,00	49,50	5,8	
30,2	86,5	-	R1/8"	FCE214	UC214	62,00	45,00	5,1	70
34,1	-	96,8	R1/8"	FCE214	EX214	62,00	45,00	5,6	
-	-	105,0	R1/8"	FCE216	UK216 + H2316	72,50	54,20	6,1	
33,3	91,5	-	R1/8"	FCE215	UC215	66,00	49,50	5,5	75
37,3	-	102,0	R1/8"	FCE215	EX215	66,00	49,50	6,1	
33,3	98,0	-	R1/8"	FCE216	UC216	72,50	54,20	5,6	80
37,3	-	110,0	R1/8"	FCE216	EX216	72,50	54,20	5,9	
-	-	120,0	R1/8"	FCE218	UK218 + H2318	96,00	71,50	9,8	
39,7	111,0	-	R1/8"	FCE218	UC218	96,00	71,50	9,6	90
24,5	-	120,0	R1/8"	FCE218	EX218	96,00	71,50	10,0	

Gehäuse FC200 nachschmierbar

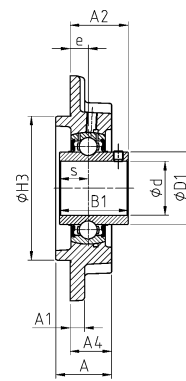
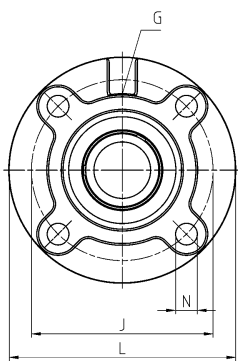
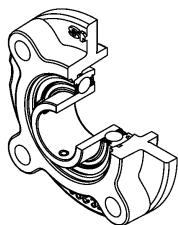

UCFC200

Wellendurchmesser		Einheit		Hauptabmessungen in mm												
d [mm]		L	J	A	A1	A2	A4	H3	e	N	s1	B	B1	s	D1	
		h8														
12	UCFC201	100	78	25,5	6	28,3	20,5	62	10	12	-	-	31,0	12,7	29,0	
	USFC201	90	70	23,0	5	26,0	19,0	55	10	12	-	-	22,0	6,0	24,6	
	ESFC201	90	70	23,0	5	32,1	19,0	55	10	12	-	-	28,6	6,5	-	
	EXFC201	100	78	25,5	6	36,5	20,5	62	10	12	-	-	43,5	17,0	-	
15	UCFC202	100	78	25,5	6	28,3	20,5	62	10	12	-	-	31,0	12,7	29,0	
	USFC202	90	70	23,0	5	26,0	19,0	55	10	12	-	-	22,0	6,0	24,6	
	ESFC202	90	70	23,0	5	32,1	19,0	55	10	12	-	-	28,6	6,5	-	
	EXFC202	100	78	25,5	6	36,5	20,5	62	10	12	-	-	43,5	17,0	-	
17	UCFC203	100	78	25,5	6	28,3	20,5	62	10	12	-	-	31,0	12,7	29,0	
	USFC203	90	70	23,0	5	26,0	19,0	55	10	12	-	-	22,0	6,0	24,6	
	ESFC203	90	70	23,0	5	32,1	19,0	55	10	12	-	-	28,6	6,5	-	
	EXFC203	100	78	25,5	6	36,5	20,5	62	10	12	-	-	43,5	17,0	-	
20	UCFC204	100	78	25,5	6	28,3	20,5	62	10	12	-	-	31,0	12,7	29,0	
	USFC204	100	78	25,5	6	28,0	20,5	62	10	12	-	-	25,0	7,0	29,0	
	ESFC204	100	78	25,5	6	33,4	20,5	62	10	12	-	-	30,9	7,5	-	
	EXFC204	100	78	25,5	6	36,5	20,5	62	10	12	-	-	43,5	17,0	-	
	UKFC205H	115	90	27,0	7	28,5	21,0	70	10	12	18,5	35,0	-	-	-	
25	UCFC205	115	90	27,0	7	29,7	21,0	70	10	12	-	-	34,0	14,3	34,0	
	USFC205	115	90	27,0	7	29,5	21,0	70	10	12	-	-	27,0	7,5	34,0	
	ESFC205	115	90	27,0	7	33,4	21,0	70	10	12	-	-	30,9	7,5	-	
	EXFC205	115	90	27,0	7	36,9	21,0	70	10	12	-	-	44,3	17,4	-	
	UKFC206H	125	100	31,0	8	30,5	23,0	80	10	12	20,5	38,0	-	-	-	
30	UCFC206	125	100	31,0	8	32,2	23,0	80	10	12	-	-	38,1	15,9	40,3	
	USFC206	125	100	31,0	8	32,0	23,0	80	10	12	-	-	30,0	8,0	40,3	
	ESFC206	125	100	31,0	8	36,7	23,0	80	10	12	-	-	35,7	9,0	-	
	EXFC206	125	100	31,0	8	40,1	23,0	80	10	12	-	-	48,3	18,2	-	
	UKFC207H	135	110	34,0	9	33,5	26,0	90	11	14	22,5	43,0	-	-	-	
35	UCFC207	135	110	34,0	9	36,4	26,0	90	11	14	-	-	42,9	17,5	48,0	
	USFC207	135	110	34,0	9	34,5	26,0	90	11	14	-	-	32,0	8,5	48,0	
	ESFC207	135	110	34,0	9	40,4	26,0	90	11	14	-	-	38,9	9,5	-	
	EXFC207	135	110	34,0	9	43,3	26,0	90	11	14	-	-	51,1	18,8	-	
	UKFC208H	145	120	36,0	9	35,5	26,0	100	11	14	24,5	46,0	-	-	-	
40	UCFC208	145	120	36,0	9	41,2	26,0	100	11	14	-	-	49,2	19,0	53,0	
	USFC208	145	120	36,0	9	36,0	26,0	100	11	14	-	-	34,0	9,0	53,0	
	ESFC208	145	120	36,0	9	43,7	26,0	100	11	14	-	-	43,7	11,0	-	
	EXFC208	145	120	36,0	9	45,9	26,0	100	11	14	-	-	56,3	21,4	-	
	UKFC209H	160	132	38,0	10	36,0	26,0	105	10	16	26,0	50,0	-	-	-	

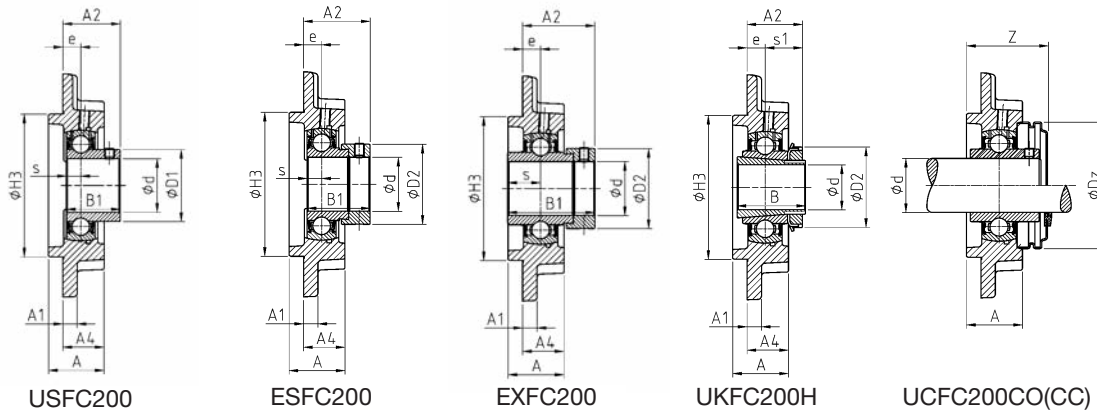

				Gehäuse	Einsatz	Schutzkappe offen *	Schutzkappe geschlossen **	Tragzahl dyn.	Tragzahl stat.	Gewicht	Wellendurch- messer
D2	G	Z	Dz					C _r [kN]	C _{or} [kN]	[kg]	d [mm]
-	M6x1	36,5	54,0	FC204	UC201	CO	CC	12,80	6,65	0,7	12
-	M6x1	34,0	46,0	FC203	US201	CO	CC	9,55	4,78	0,5	
28,6	M6x1	***	***	FC203	ES201	***	***	9,55	4,78	0,5	
33,3	M6x1	***	***	FC204	EX201	***	***	12,80	6,65	0,8	
-	M6x1	36,5	54,0	FC204	UC202	CO	CC	12,80	6,65	0,7	15
-	M6x1	34,0	46,0	FC203	US202	CO	CC	9,55	4,78	0,5	
28,6	M6x1	***	***	FC203	ES202	***	***	9,55	4,78	0,5	
33,3	M6x1	***	***	FC204	EX202	***	***	12,80	6,65	0,7	
-	M6x1	36,5	54,0	FC204	UC203	CO	CC	12,80	6,65	0,6	17
-	M6x1	34,0	46,0	FC203	US203	CO	CC	9,55	4,78	0,5	
28,6	M6x1	***	***	FC203	ES203	***	***	9,55	4,78	0,5	
33,3	M6x1	***	***	FC204	EX203	***	***	12,80	6,65	0,7	
-	M6x1	36,5	54,0	FC204	UC204	CO	CC	12,80	6,65	0,6	20
-	M6x1	36,5	54,0	FC204	US204	CO	CC	12,80	6,65	0,6	
33,3	M6x1	***	***	FC204	ES204	***	***	12,80	6,65	0,6	
33,3	M6x1	***	***	FC204	EX204	***	***	12,80	6,65	0,7	
38,0	M6x1	39,1	60,0	FC205	UK205 + H2305	CO	CC	14,00	7,88	1,0	
-	M6x1	39,1	60,0	FC205	UC205	CO	CC	14,00	7,88	1,0	25
-	M6x1	39,1	60,0	FC205	US205	CO	CC	14,00	7,88	0,9	
38,1	M6x1	***	***	FC205	ES205	***	***	14,00	7,88	0,9	
38,1	M6x1	***	***	FC205	EX205	***	***	14,00	7,88	1,0	
45,0	M6x1	44,1	70,0	FC206	UK206 + H2306	CO	CC	19,50	11,20	1,3	
-	M6x1	44,1	70,0	FC206	UC206	CO	CC	19,50	11,20	1,3	30
-	M6x1	44,1	70,0	FC206	US206	CO	CC	19,50	11,20	1,2	
44,5	M6x1	***	***	FC206	ES206	***	***	19,50	11,20	1,3	
44,5	M6x1	***	***	FC206	EX206	***	***	19,50	11,20	1,4	
52,0	M6x1	48,8	80,0	FC207	UK207 + H2307	CO	CC	25,70	15,20	1,7	
-	M6x1	48,8	80,0	FC207	UC207	CO	CC	25,70	15,20	1,7	35
-	M6x1	48,8	80,0	FC207	US207	CO	CC	25,70	15,20	1,6	
55,6	M6x1	***	***	FC207	ES207	***	***	25,70	15,20	1,7	
55,6	M6x1	***	***	FC207	EX207	***	***	25,70	15,20	1,8	
58,0	M6x1	55,1	88,0	FC208	UK208 + H2308	CO	CC	29,60	18,20	2,1	
-	M6x1	55,1	88,0	FC208	UC208	CO	CC	29,60	18,20	2,0	40
-	M6x1	55,1	88,0	FC208	US208	CO	CC	29,60	18,20	2,0	
60,3	M6x1	***	***	FC208	ES208	***	***	29,60	18,20	2,0	
60,3	M6x1	***	***	FC208	EX208	***	***	29,60	18,20	2,2	
65,0	M6x1	56,7	95,0	FC209	UK209 + H2309	CO	CC	31,85	20,80	2,6	

* = mit einer offenen Schutzkappe für durchgehende Wellen: Nachsetzzeichen CO wie Bestellbeispiel Seite 6

** = mit einer geschlossenen Schutzkappe für Wellenenden: Nachsetzzeichen CC wie Bestellbeispiel Seite 6

*** = mit Schutzkappen für Einsätze mit Excentering auf Anfrage lieferbar

Gehäuse FC200 nachschmierbar

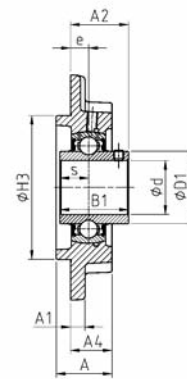
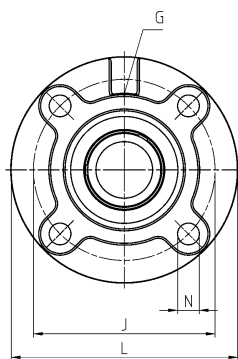
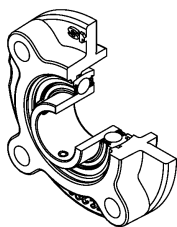

UCFC200

Wellendurchmesser		Einheit		Hauptabmessungen in mm												
d [mm]		L	J	A	A1	A2	A4	H3	e	N	s1	B	B1	s	D1	
								h8								
45	UCFC209	160	132	38,0	10	40,2	26,0	105	10	16	-	-	49,2	19,0	57,2	
	USFC209	160	132	38,0	10	41,0	26,0	105	10	16	-	-	41,2	10,2	57,2	
	ESFC209	160	132	38,0	10	42,7	26,0	105	10	16	-	-	43,7	11,0	-	
	EXFC209	160	132	38,0	10	44,9	26,0	105	10	16	-	-	56,3	21,4	-	
	UKFC210H	165	138	40,0	14	37,5	28,0	110	10	16	27,5	55,0	-	-	-	
50	UCFC210	165	138	40,0	14	42,6	28,0	110	10	16	-	-	51,6	19,0	61,8	
	USFC210	165	138	40,0	14	42,6	28,0	110	10	16	-	-	43,5	10,9	61,8	
	ESFC210	165	138	40,0	14	42,7	28,0	110	10	16	-	-	43,7	11,0	-	
	EXFC210	165	138	40,0	14	48,1	28,0	110	10	16	-	-	62,7	24,6	-	
	UKFC211H	185	150	42,0	13	42,0	30,0	125	13	19	29,0	59,0	-	-	-	
55	UCFC211	185	150	42,0	13	46,4	30,0	125	13	19	-	-	55,6	22,2	69,0	
	USFC211	185	150	42,0	13	46,5	30,0	125	13	19	-	-	45,3	11,8	69,0	
	ESFC211	185	150	42,0	13	49,4	30,0	125	13	19	-	-	48,4	12,0	-	
	EXFC211	185	150	42,0	13	56,6	30,0	125	13	19	-	-	71,3	27,7	-	
	UKFC212H	195	160	48,0	15	48,0	36,0	135	17	19	31,0	62,0	-	-	-	
60	UCFC212	195	160	48,0	15	56,7	36,0	135	17	19	-	-	65,1	25,4	74,9	
	USFC212	195	160	48,0	15	55,8	36,0	135	17	19	-	-	53,7	14,9	74,9	
	ESFC212	195	160	48,0	15	54,3	36,0	135	17	19	-	-	49,3	12,0	-	
	EXFC212	195	160	48,0	15	63,8	36,0	135	17	19	-	-	77,7	30,9	-	
	UKFC213H	205	170	49,0	15	48,0	35,0	145	16	19	32,0	65,0	-	-	-	
65	UCFC213	205	170	49,0	15	55,7	35,0	145	16	19	-	-	65,1	25,4	82,0	
	EXFC213	205	170	49,0	15	67,6	35,0	145	16	19	-	-	85,7	34,1	-	
	UKFC215H	220	184	55,0	17	53,5	39,0	160	18	19	35,5	73,0	-	-	-	
70	UCFC214	215	177	52,0	16	61,4	38,0	150	17	19	-	-	74,6	30,2	86,5	
	EXFC214	215	177	52,0	16	68,6	38,0	150	17	19	-	-	85,7	34,1	-	
	UKFC216H	240	200	58,0	18	57,0	42,0	170	18	23	39,0	78,0	-	-	-	
75	UCFC215	220	184	55,0	17	62,5	39,0	160	18	19	-	-	77,8	33,3	91,5	
	EXFC215	220	184	55,0	17	72,8	39,0	160	18	19	-	-	92,1	37,3	-	
	UKFC217H	250	208	63,0	20	58,0	45,0	180	18	23	40,0	82,0	-	-	-	
80	UCFC216	240	200	58,0	18	67,3	42,0	170	18	23	-	-	82,6	33,3	98,0	
	EXFC216	240	200	58,0	18	75,9	42,0	170	18	23	-	-	95,2	37,3	-	
	UKFC218H	265	220	68,0	20	64,0	50,0	190	22	23	42,0	86,0	-	-	-	
85	UCFC217	250	208	63,0	20	69,6	45,0	180	18	23	-	-	85,7	34,1	105,1	
	EXFC217	250	208	63,0	20	65,6	45,0	180	18	23	-	-	73,2	23,4	-	
90	UCFC218	265	220	68,0	20	78,3	50,0	190	22	23	-	-	96,0	39,7	111,0	
	EXFC218	265	220	68,0	20	68,5	50,0	190	22	23	-	-	72,5	24,5	-	

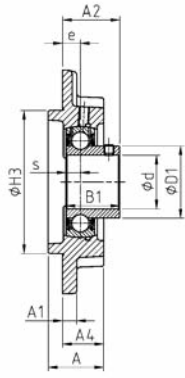

USFC200

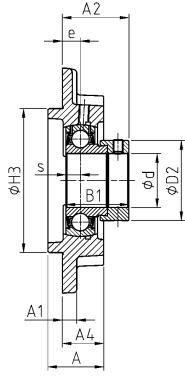

ESFC200

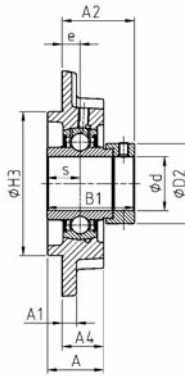

EXFC200

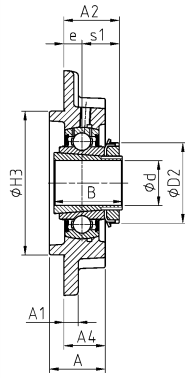

UKFC200H

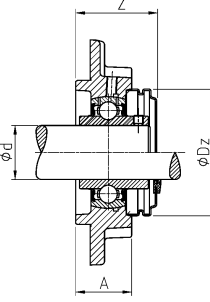

UCFC200CO(CC)

D2	G	Z	Dz	Gehäuse		Einsatz		Tragzahl dyn.	Tragzahl stat.	Gewicht	Wellendurchmesser
				FC	UC	CO	CC	C _r [kN]	C _{or} [kN]	[kg]	d [mm]
-	M6x1	56,7	95,0	FC209	UC209	CO	CC	31,85	20,80	2,5	45
-	M6x1	56,7	95,0	FC209	US209	CO	CC	31,85	20,80	2,4	45
63,5	M6x1	***	***	FC209	ES209	***	***	31,85	20,80	2,5	45
63,5	M6x1	***	***	FC209	EX209	***	***	31,85	20,80	2,7	45
70,0	M6x1	59,3	100,0	FC210	UK210 + H2310	CO	CC	35,10	23,20	3,0	50
-	M6x1	59,3	100,0	FC210	UC210	CO	CC	35,10	23,20	2,9	50
-	M6x1	59,3	100,0	FC210	US210	CO	CC	35,10	23,20	2,8	50
69,9	M6x1	***	***	FC210	ES210	***	***	35,10	23,20	2,9	50
69,9	M6x1	***	***	FC210	EX210	***	***	35,10	23,20	3,1	50
75,0	M6x1	62,8	110,0	FC211	UK211 + H2311	CO	CC	43,55	29,20	3,9	55
-	M6x1	62,8	110,0	FC211	UC211	CO	CC	43,55	29,20	3,9	55
-	M6x1	62,8	110,0	FC211	US211	CO	CC	43,55	29,20	3,8	55
76,2	M6x1	***	***	FC211	ES211	***	***	43,55	29,20	3,6	55
76,2	M6x1	***	***	FC211	EX211	***	***	43,55	29,20	4,1	55
80,0	M6x1	73,2	120,0	FC212	UK212 + H2312	CO	CC	52,50	32,80	4,9	60
-	M6x1	73,2	120,0	FC212	UC212	CO	CC	52,50	32,80	5,0	60
-	M6x1	73,2	120,0	FC212	US212	CO	CC	52,50	32,80	4,7	60
84,2	M6x1	***	***	FC212	ES212	***	***	52,50	32,80	4,6	60
84,2	M6x1	***	***	FC212	EX212	***	***	52,50	32,80	5,3	60
85,0	M6x1	74,5	132,0	FC213	UK213 + H2313	CO	CC	57,20	40,00	5,6	65
-	M6x1	74,5	132,0	FC213	UC213	CO	CC	57,20	40,00	5,5	65
86,0	M6x1	***	***	FC213	EX213	***	***	57,20	40,00	6,1	65
98,0	M10x1	-	-	FC215	UK215 + H2315	-	-	66,00	49,50	6,4	70
-	M10x1	-	-	FC214	UC214	-	-	62,00	45,00	6,4	70
96,8	M10x1	-	-	FC214	EX214	-	-	62,00	45,00	6,9	70
105,0	M10x1	-	-	FC216	UK216 + H2316	-	-	72,50	54,20	9,5	75
-	M10x1	-	-	FC215	UC215	-	-	66,00	49,50	7,2	75
102,0	M10x1	-	-	FC215	EX215	-	-	66,00	49,50	7,8	75
110,0	M10x1	-	-	FC217	UK217 + H2317	-	-	83,20	63,80	11,1	80
-	M10x1	-	-	FC216	UC216	-	-	72,50	54,20	9,0	80
110,0	M10x1	-	-	FC216	EX216	-	-	72,50	54,20	9,4	80
120,0	M10x1	-	-	FC218	UK218 + H2318	-	-	96,00	71,50	13,4	85
-	M10x1	-	-	FC217	UC217	-	-	83,20	63,80	10,6	85
119,0	M10x1	-	-	FC217	EX217	-	-	83,20	63,80	11,0	85
-	M10x1	-	-	FC218	UC218	-	-	96,00	71,50	13,2	90
120,0	M10x1	-	-	FC218	EX218	-	-	96,00	71,50	13,6	90

* = mit einer offenen Schutzkappe für durchgehende Wellen: Nachsetzzeichen CO wie Bestellbeispiel Seite 6

** = mit einer geschlossenen Schutzkappe für Wellenenden: Nachsetzzeichen CC wie Bestellbeispiel Seite 6

*** = mit Schutzkappen für Einsätze mit Excentering auf Anfrage lieferbar



Gehäuse FEE200 nachschmierbar

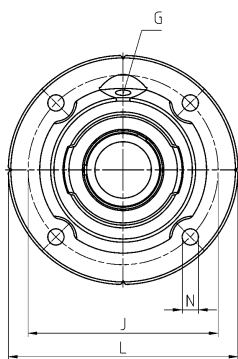
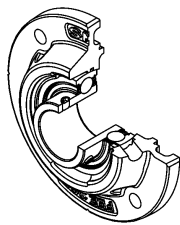

Wellendurchmesser		Einheit		Hauptabmessungen in mm								
d [mm]		L	J	A	A1	A2	A4	H3 h8	e	N	B1	
25	USFEE205	115	92	23,5	9,0	29,0	20,5	75	9,5	9,0	27,0	
	ESFEE205	115	92	23,5	9,0	32,9	20,5	75	9,5	9,0	30,9	
30	USFEE206	127	105	27,0	9,5	32,5	24,0	85	10,5	9,0	30,0	
	ESFEE206	127	105	27,0	9,5	37,2	24,0	85	10,5	9,0	35,7	
35	USFEE207	135	110	28,0	10,0	32,5	24,0	90	9,0	11,5	32,0	
	ESFEE207	135	110	28,0	10,0	38,4	24,0	90	9,0	11,5	38,9	
40	USFEE208	145	120	31,0	11,5	36,5	27,0	100	11,5	11,5	34,0	
	ESFEE208	145	120	31,0	11,5	44,2	27,0	100	11,5	11,5	43,7	
45	USFEE209	155	130	31,5	12,0	42,5	27,5	105	11,5	14,0	41,2	
	ESFEE209	155	130	31,5	12,0	44,2	27,5	105	11,5	14,0	43,7	
50	USFEE210	165	136	32,5	13,0	45,1	28,5	115	12,5	14,0	43,5	
	ESFEE210	165	136	32,5	13,0	45,2	28,5	115	12,5	14,0	43,7	
60	USFEE212	195	165	40,5	16,0	55,8	36,5	140	17,0	14,0	53,7	
	ESFEE212	195	165	40,5	16,0	54,3	36,5	140	17,0	14,0	49,3	

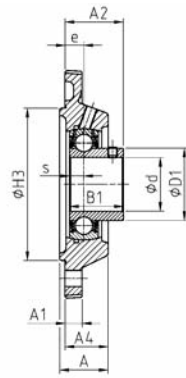

USFEE200

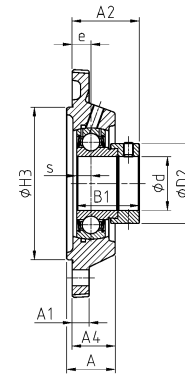

ESFEE200

s	D1	D2	G	Gehäuse		Einsatz		Tragzahl dyn.	Tragzahl stat.	Gewicht [kg]	Wellendurch- messer [mm]
				FEE	US	FEE	ES				
						C _r [kN]	C _{or} [kN]				
7,5	34,0	-	R1/8"	FEE205	US205	14,00	7,88	0,8	25		
7,5	-	38,1	R1/8"	FEE205	ES205	14,00	7,88	0,8			
8,0	40,3	-	R1/8"	FEE206	US206	19,50	11,20	1,1	30		
9,0	-	44,5	R1/8"	FEE206	ES206	19,50	11,20	1,2			
8,5	48,0	-	R1/8"	FEE207	US207	25,70	15,20	1,4	35		
9,5	-	55,6	R1/8"	FEE207	ES207	25,70	15,20	1,5			
9,0	53,0	-	R1/8"	FEE208	US208	29,60	18,20	1,8	40		
11,0	-	60,3	R1/8"	FEE208	ES208	29,60	18,20	1,9			
10,2	57,2	-	R1/8"	FEE209	US209	31,85	20,80	2,1	45		
11,0	-	63,5	R1/8"	FEE209	ES209	31,85	20,80	2,1			
10,9	61,8	-	R1/8"	FEE210	US210	35,10	23,20	2,5	50		
11,0	-	69,9	R1/8"	FEE210	ES210	35,10	23,20	2,5			
14,9	74,9	-	R1/8"	FEE212	US212	52,50	32,80	4,3	60		
12,0	-	84,2	R1/8"	FEE212	ES212	52,50	32,80	4,2			

Gehäuse FS300 nachschmierbar

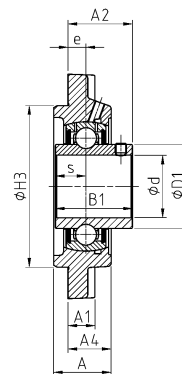
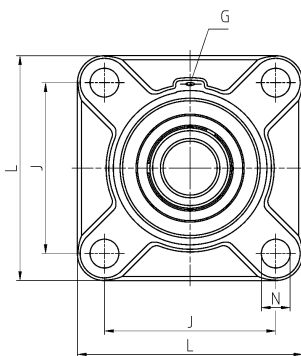
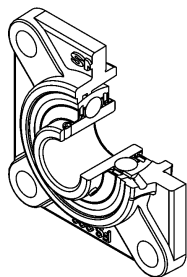

UCFS300

Hauptabmessungen in mm

d [mm]	Wellendurchmesser Einheit	L	J	A	A1	A2	A4	H3 h8	e	N	s1	B	B1	s
20	UKFS305H	110	80	29	13	30,5	22	80	9	16	21,5	35,0	-	-
25	UCFS305	110	80	29	13	32,0	22	80	9	16	-	-	38,0	15,0
	EXFS305	110	80	29	13	39,1	22	80	9	16	-	-	46,8	16,7
	UKFS306H	125	95	32	15	33,0	24	90	10	16	23,0	38,0	-	-
30	UCFS306	125	95	32	15	36,0	24	90	10	16	-	-	43,0	17,0
	EXFS306	125	95	32	15	42,5	24	90	10	16	-	-	50,0	17,5
	UKFS307H	135	100	36	16	36,5	27	100	11	19	25,5	43,0	-	-
35	UCFS307	135	100	36	16	40,0	27	100	11	19	-	-	48,0	19,0
	EXFS307	135	100	36	16	44,3	27	100	11	19	-	-	51,6	18,3
	UKFS308H	150	112	40	17	40,5	30	115	13	19	27,5	46,0	-	-
40	UCFS308	150	112	40	17	46,0	30	115	13	19	-	-	52,0	19,0
	EXFS308	150	112	40	17	50,3	30	115	13	19	-	-	57,1	19,8
	UKFS309H	160	125	44	18	44,0	33	125	14	19	30,0	50,0	-	-
45	UCFS309	160	125	44	18	49,0	33	125	14	19	-	-	57,0	22,0
	EXFS309	160	125	44	18	52,9	33	125	14	19	-	-	58,7	19,8
	UKFS310H	175	132	48	19	48,0	36	140	16	23	32,0	55,0	-	-
50	UCFS310	175	132	48	19	55,0	36	140	16	23	-	-	61,0	22,0
	EXFS310	175	132	48	19	58,0	36	140	16	23	-	-	66,6	24,6
	UKFS311H	185	140	52	20	51,0	39	150	17	23	34,0	59,0	-	-
55	UCFS311	185	140	52	20	58,0	39	150	17	23	-	-	66,0	25,0
	EXFS311	185	140	52	20	62,2	39	150	17	23	-	-	73,0	27,8
	UKFS312H	195	150	56	22	55,5	42	160	19	23	36,5	62,0	-	-
60	UCFS312	195	150	56	22	64,0	42	160	19	23	-	-	71,0	26,0
	EXFS312	195	150	56	22	67,4	42	160	19	23	-	-	79,4	30,95
	UKFS313H	208	166	58	22	53,5	40	175	15	23	38,5	65,0	-	-
65	UCFS313	208	166	58	22	60,0	40	175	15	23	-	-	75,0	30,0
	EXFS313	208	166	58	22	68,2	40	175	15	23	-	-	85,7	32,5
	UKFS315H	236	184	66	25	63,5	48	200	21	25	42,5	73,0	-	-
70	UCFS314	226	178	61	25	65,0	43	185	18	25	-	-	78,0	33,0
	EXFS314	226	178	61	25	75,9	43	185	18	25	-	-	92,1	34,15
	UKFS316H	250	196	68	27	62,5	48	210	18	31	44,5	78,0	-	-
75	UCFS315	236	184	66	25	71,0	48	200	21	25	-	-	82,0	32,0
	EXFS315	236	184	66	25	83,7	48	200	21	25	-	-	100,0	37,3
	UKFS317H	260	204	74	27	72,0	54	220	24	31	48,0	82,0	-	-

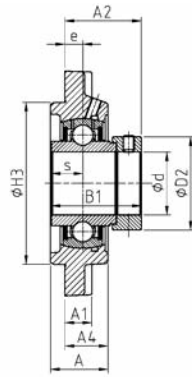

EXFS300

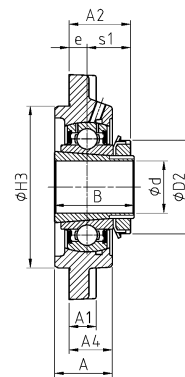

UKFS300H

D1	D2	G			C _r [kN]	C _{0r} [kN]	Gewicht [kg]	Wellendurch- messer [mm]
			Gehäuse	Einsatz				
35,4	38,0	M6x1	FS305	UK305 + H2305	22,36	11,50	1,4	20
35,4	-	M6x1	FS305	UC305	22,36	11,50	1,2	25
-	42,8	M6x1	FS305	EX305	22,36	11,50	1,3	
-	45,0	M6x1	FS306	UK306 + H2306	27,00	15,20	1,8	
44,6	-	M6x1	FS306	UC306	27,00	15,20	1,8	30
-	50,0	M6x1	FS306	EX306	27,00	15,20	1,9	
-	52,0	M6x1	FS307	UK307 + H2307	33,50	19,20	2,5	
48,9	-	M6x1	FS307	UC307	33,50	19,20	2,3	35
-	55,0	M6x1	FS307	EX307	33,50	19,20	2,4	
-	58,0	M6x1	FS308	UK308 + H2308	40,56	24,00	3,2	
56,5	-	M6x1	FS308	UC308	40,56	24,00	3,1	40
-	63,5	M6x1	FS308	EX308	40,56	24,00	3,2	
-	65,0	M6x1	FS309	UK309 + H2309	53,00	31,80	4,0	
61,8	-	M6x1	FS309	UC309	53,00	31,80	3,9	45
-	70,0	M6x1	FS309	EX309	53,00	31,80	4,0	
-	70,0	M6x1	FS310	UK310 + H2310	62,00	37,80	5,0	
68,7	-	M6x1	FS310	UC310	62,00	37,80	4,9	50
-	76,2	M6x1	FS310	EX310	62,00	37,80	5,1	
-	75,0	M6x1	FS311	UK311 + H2311	71,50	44,80	6,0	
74,9	-	M6x1	FS311	UC311	71,50	44,80	5,7	55
-	83,0	M6x1	FS311	EX311	71,50	44,80	6,1	
-	80,0	M6x1	FS312	UK312 + H2312	81,60	51,80	7,4	
81,0	-	M6x1	FS312	UC312	81,60	51,80	7,5	60
-	89,0	M6x1	FS312	EX312	81,60	51,80	7,8	
-	85,0	M6x1	FS313	UK313 + H2313	93,86	60,50	8,8	
87,5	-	M6x1	FS313	UC313	93,86	60,50	8,8	65
-	97,0	M6x1	FS313	EX313	93,86	60,50	9,2	
-	98,0	M10x1	FS315	UK315 + H2315	113,36	76,80	13,1	
94,0	-	M10x1	FS314	UC314	104,26	68,00	11,0	70
-	102,0	M10x1	FS314	EX314	104,26	68,00	11,5	
-	105,0	M10x1	FS316	UK316 + H2316	122,85	86,50	15,1	
100,5	-	M10x1	FS315	UC315	113,36	76,80	12,4	75
-	113,0	M10x1	FS315	EX315	113,36	76,80	13,5	
-	110,0	M10x1	FS317	UK317 + H2317	132,60	96,50	17,3	

Gehäuse FS300 nachschmierbar

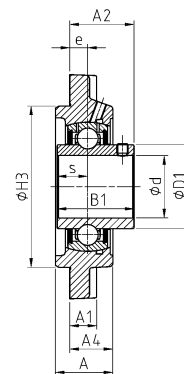
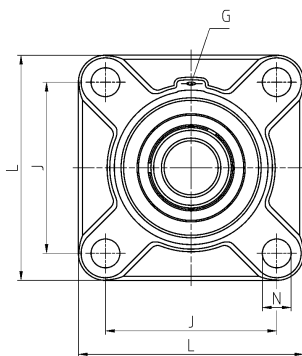
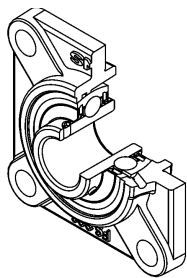

UCFS300

Wellendurchmesser		Einheit		Hauptabmessungen in mm										
d [mm]		L	J	A	A1	A2	A4	H3	e	N	s1	B	B1	s
		h8												
80	UCFS316	250	196	68	27	70,0	48	210	18	31	-	-	86,0	34,0
	EXFS316	250	196	68	27	83,9	48	210	18	31	-	-	106,4	40,5
	UKFS318H	280	216	76	30	72,0	56	240	24	35	48,0	86,0	-	-
85	UCFS317	260	204	74	27	80,0	54	220	24	31	-	-	96,0	40,0
	EXFS317	260	204	74	27	91,5	54	220	24	31	-	-	109,5	42,0
	UKFS319H	290	228	94	30	91,0	74	250	39	35	52,0	90,0	-	-
90	UCFS318	280	216	76	30	80,0	56	240	24	35	-	-	96,0	40,0
	EXFS318	280	216	76	30	96,3	56	240	24	35	-	-	115,9	43,6
	UKFS320H	310	242	94	32	93,0	74	260	39	38	54,0	97,0	-	-
95	UCFS319	290	228	94	30	101,0	74	250	39	35	-	-	103,0	41,0
	EXFS319	290	228	94	30	114,5	74	250	39	35	-	-	122,3	46,8
100	UCFS320	310	242	94	32	105,0	74	260	39	38	-	-	108,0	42,0
	EXFS320	310	242	94	32	117,6	74	260	39	38	-	-	128,6	50,0
	UKFS322H	340	266	96	35	96,0	71	300	35	41	61,0	105,0	-	-
105	UCFS321	310	242	94	32	107,0	74	260	39	38	-	-	112,0	44,0
110	UCFS322	340	266	96	35	106,0	71	300	35	41	-	-	117,0	46,0
	UKFS324H	370	290	110	40	100,0	80	330	35	41	65,0	112,0	-	-
115	UKFS326H	410	320	115	45	104,0	85	360	35	41	69,0	121,0	-	-
120	UCFS324	370	290	110	40	110,0	80	330	35	41	-	-	126,0	51,0
125	UKFS328H	450	350	125	55	118,0	95	400	45	41	73,0	131,0	-	-
130	UCFS326	410	320	115	45	116,0	85	360	35	41	-	-	135,0	54,0
140	UCFS328	450	350	125	55	131,0	95	400	45	41	-	-	145,0	59,0

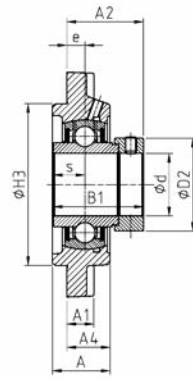

EXFS300

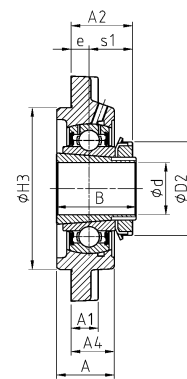

UKFS300H

Gehäuse

Einsatz

Tragzahl
dyn.Tragzahl
stat.

Gewicht

Wellendurch-
messer

D1	D2	G			C_r [kN]	C_{or} [kN]	[kg]	d [mm]
107,9	-	M10x1	FS316	UC316	122,85	86,50	14,9	80
-	119,0	M10x1	FS316	EX316	122,85	86,50	16,0	
-	120,0	M10x1	FS318	UK318 + H2318	143,00	108,00	21,3	
114,0	-	M10x1	FS317	UC317	132,60	96,50	17,3	85
-	127,0	M10x1	FS317	EX317	132,60	96,50	18,4	
-	125,0	M10x1	FS319	UK319 + H2319	156,00	122,00	25,2	
120,0	-	M10x1	FS318	UC318	143,00	108,00	21,2	90
-	133,0	M10x1	FS318	EX318	143,00	108,00	22,4	
134,5	130,0	M10x1	FS320	UK320 + H2320	171,60	140,00	29,1	
126,5	-	M10x1	FS319	UC319	156,00	122,00	24,9	95
-	140,0	M10x1	FS319	EX319	156,00	122,00	26,4	
134,5	-	M10x1	FS320	UC320	171,60	140,00	29,4	
-	146,0	M10x1	FS320	EX320	171,60	140,00	31,2	100
-	145,0	M10x1	FS322	UK322 + H2322	205,00	178,00	41,6	
140,5	-	M10x1	FS321	UC321	182,00	155,00	29,8	
149,0	-	M10x1	FS322	UC322	205,00	178,00	38,3	110
-	155,0	M10x1	FS324	UK324 + H2324	228,00	208,00	54,4	
176,1	165,0	M10x1	FS326	UK326 + H2326	252,00	242,00	72,8	
163,0	-	M10x1	FS324	UC324	228,00	208,00	51,7	120
-	180,0	M10x1	FS328	UK328 + H2328	275,00	272,00	98,7	125
177,0	-	M10x1	FS326	UC326	252,00	242,00	67,9	130
190,0	-	M10x1	FS328	UC328	275,00	272,00	92,8	140

Gehäuse FTE200 nachschmierbar

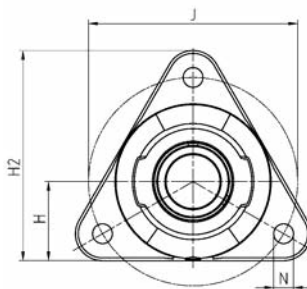
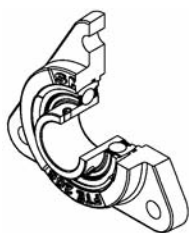

Wellendurchmesser
Einheit

Hauptabmessungen in mm

d [mm]		H	J	A	A1	A2	H2	e	N
12	USFTE201	31	76,1	20	11	26,0	81	10,0	11,5
	ESFTE201	31	76,1	20	11	32,1	81	10,0	11,5
15	USFTE202	31	76,1	20	11	26,0	81	10,0	11,5
	ESFTE202	31	76,1	20	11	32,1	81	10,0	11,5
17	USFTE203	31	76,1	20	11	26,0	81	10,0	11,5
	ESFTE203	31	76,1	20	11	32,1	81	10,0	11,5
20	USFTE204	35	89,5	20	11	29,0	92	11,0	11,5
	ESFTE204	35	89,5	20	11	34,4	92	11,0	11,5
25	USFTE205	36	96,0	22	12	32,1	97	12,6	11,0
	ESFTE205	36	96,0	22	12	36,0	97	12,6	11,0
30	USFTE206	44	116,0	24	12	35,0	117	13,0	11,0
	ESFTE206	44	116,0	24	12	39,7	117	13,0	11,0
35	USFTE207	48	129,7	27	16	39,1	128	15,6	13,5
	ESFTE207	48	129,7	27	16	45,0	128	15,6	13,5
40	USFTE208	51	140,0	30	16	43,8	137	18,8	13,5
	ESFTE208	51	140,0	30	16	51,5	137	18,8	13,5
45	USFTE209	55	160,0	33	16	50,2	150	19,2	14,0
	ESFTE209	55	160,0	33	16	51,9	150	19,2	14,0
50	USFTE210	55	160,0	33	16	51,8	150	19,2	14,0
	ESFTE210	55	160,0	33	16	51,9	150	19,2	14,0

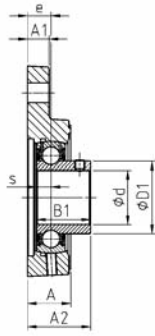

USFTE200

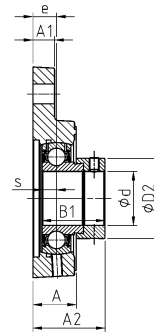

ESFTE200

B1	s	D1	D2	G	Gehäuse	Einsatz	Tragzahl dyn.	Tragzahl stat.	Gewicht	Wellendurch- messer
22,0	6,0	24,6	-	M6x1	FTE202	US201	9,55	4,78	0,4	12
28,6	6,5	-	28,6	M6x1	FTE202	ES201	9,55	4,78	0,4	
22,0	6,0	24,6	-	M6x1	FTE202	US202	9,55	4,78	0,4	15
28,6	6,5	-	28,6	M6x1	FTE202	ES202	9,55	4,78	0,4	
22,0	6,0	24,6	-	M6x1	FTE202	US203	9,55	4,78	0,4	17
28,6	6,5	-	28,6	M6x1	FTE202	ES203	9,55	4,78	0,4	
25,0	7,0	29,0	-	R1/8"	FTE204	US204	12,80	6,65	0,6	20
30,9	7,5	-	33,3	R1/8"	FTE204	ES204	12,80	6,65	0,6	
27,0	7,5	34,0	-	R1/8"	FTE205	US205	14,00	7,88	0,6	25
30,9	7,5	-	38,1	R1/8"	FTE205	ES205	14,00	7,88	0,6	
30,0	8,0	40,3	-	R1/8"	FTE206	US206	19,50	11,20	1,0	30
35,7	9,0	-	44,5	R1/8"	FTE206	ES206	19,50	11,20	1,1	
32,0	8,5	48,0	-	R1/8"	FTE207	US207	25,70	15,20	1,4	35
38,9	9,5	-	55,6	R1/8"	FTE207	ES207	25,70	15,20	1,5	
34,0	9,0	53,0	-	R1/8"	FTE208	US208	29,60	18,20	1,7	40
43,7	11,0	-	60,3	R1/8"	FTE208	ES208	29,60	18,20	1,7	
41,2	10,2	57,2	-	R1/8"	FTE209	US209	31,85	20,80	2,1	45
43,7	11,0	-	63,5	R1/8"	FTE209	ES209	31,85	20,80	2,1	
43,5	10,9	61,8	-	R1/8"	FTE210	US210	35,10	23,20	2,0	50
43,7	11,0	-	69,9	R1/8"	FTE210	ES210	35,10	23,20	2,1	

Gehäuse FLE200 nachschmierbar

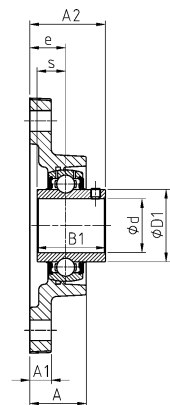
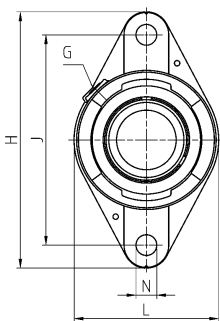
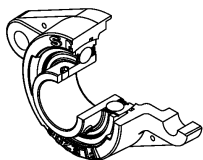

UCFLE200

Wellendurchmesser		Einheit		Hauptabmessungen in mm												
d [mm]		L	H	J	A	A1	A2	e	N	s1	B	B1	s	D1	D2	
12	UCFLE201	61	112	90,0	30,3	10,0	37,3	19	11,5	-	-	31,0	12,7	29,0	-	
	USFLE201	57	99	76,5	26,0	9,5	33,0	17	11,5	-	-	22,0	6,0	24,6	-	
	ESFLE201	57	99	76,5	26,0	9,5	33,0	17	11,5	-	-	28,6	6,5	-	28,6	
	EXFLE201	61	112	90,0	30,3	10,0	37,3	19	11,5	-	-	43,5	17,0	-	33,3	
15	UCFLE202	61	112	90,0	30,3	10,0	37,3	19	11,5	-	-	31,0	12,7	29,0	-	
	USFLE202	57	99	76,5	26,0	9,5	33,0	17	11,5	-	-	22,0	6,0	24,6	-	
	ESFLE202	57	99	76,5	26,0	9,5	33,0	17	11,5	-	-	28,6	6,5	-	28,6	
	EXFLE202	61	112	90,0	30,3	10,0	37,3	19	11,5	-	-	43,5	17,0	-	33,3	
17	UCFLE203	61	112	90,0	30,3	10,0	37,3	19	11,5	-	-	31,0	12,7	29,0	-	
	USFLE203	57	99	76,5	26,0	9,5	33,0	17	11,5	-	-	22,0	6,0	24,6	-	
	ESFLE203	57	99	76,5	26,0	9,5	33,0	17	11,5	-	-	28,6	6,5	-	28,6	
	EXFLE203	61	112	90,0	30,3	10,0	37,3	19	11,5	-	-	43,5	17,0	-	33,3	
20	UCFLE204	61	112	90,0	30,3	10,0	37,3	19	11,5	-	-	31,0	12,7	29,0	-	
	USFLE204	61	112	90,0	30,3	10,0	37,0	19	11,5	-	-	25,0	7,0	29,0	-	
	ESFLE204	61	112	90,0	30,3	10,0	42,4	19	11,5	-	-	30,9	7,5	-	33,3	
	EXFLE204	61	112	90,0	30,3	10,0	45,5	19	11,5	-	-	43,5	17,0	-	33,3	
	UKFLE205H	70	124	99,0	29,3	11,0	37,5	19	11,5	18,5	35,0	-	-	-	38,0	
25	UCFLE205	70	124	99,0	29,3	11,0	38,7	19	11,5	-	-	34,0	14,3	34,0	-	
	USFLE205	70	124	99,0	29,3	11,0	38,5	19	11,5	-	-	27,0	7,5	34,0	-	
	ESFLE205	70	124	99,0	29,3	11,0	42,4	19	11,5	-	-	30,9	7,5	-	38,1	
	EXFLE205	70	124	99,0	29,3	11,0	45,9	19	11,5	-	-	44,3	17,4	-	38,1	
	UKFLE206H	80	142	116,5	32,1	12,0	40,5	20	11,5	20,5	38,0	-	-	-	45,0	
30	UCFLE206	80	142	116,5	32,1	12,0	42,2	20	11,5	-	-	38,1	15,9	40,3	-	
	USFLE206	80	142	116,5	32,1	12,0	42,0	20	11,5	-	-	30,0	8,0	40,3	-	
	ESFLE206	80	142	116,5	32,1	12,0	46,7	20	11,5	-	-	35,7	9,0	-	44,5	
	EXFLE206	80	142	116,5	32,1	12,0	50,1	20	11,5	-	-	48,3	18,2	-	44,5	
	UKFLE207H	92	155	130,0	33,7	12,5	43,5	21	14,0	22,5	43,0	-	-	-	52,0	
35	UCFLE207	92	155	130,0	33,7	12,5	46,4	21	14,0	-	-	42,9	17,5	48,0	-	
	USFLE207	92	155	130,0	33,7	12,5	44,5	21	14,0	-	-	32,0	8,5	48,0	-	
	ESFLE207	92	155	130,0	33,7	12,5	50,4	21	14,0	-	-	38,9	9,5	-	55,6	
	EXFLE207	92	155	130,0	33,7	12,5	53,3	21	14,0	-	-	51,1	18,8	-	55,6	
	UKFLE208H	105	172	143,5	37,5	13,0	48,5	24	14,0	24,5	46,0	-	-	-	58,0	
40	UCFLE208	105	172	143,5	37,5	13,0	54,2	24	14,0	-	-	49,2	19,0	53,0	-	
	USFLE208	105	172	143,5	37,5	13,0	49,0	24	14,0	-	-	34,0	9,0	53,0	-	
	ESFLE208	105	172	143,5	37,5	13,0	56,7	24	14,0	-	-	43,7	11,0	-	60,3	
	EXFLE208	105	172	143,5	37,5	13,0	58,9	24	14,0	-	-	56,3	21,4	-	60,3	
	UKFLE209H	111	180	148,5	37,5	13,0	50,0	24	14,0	26,0	50,0	-	-	-	65,0	

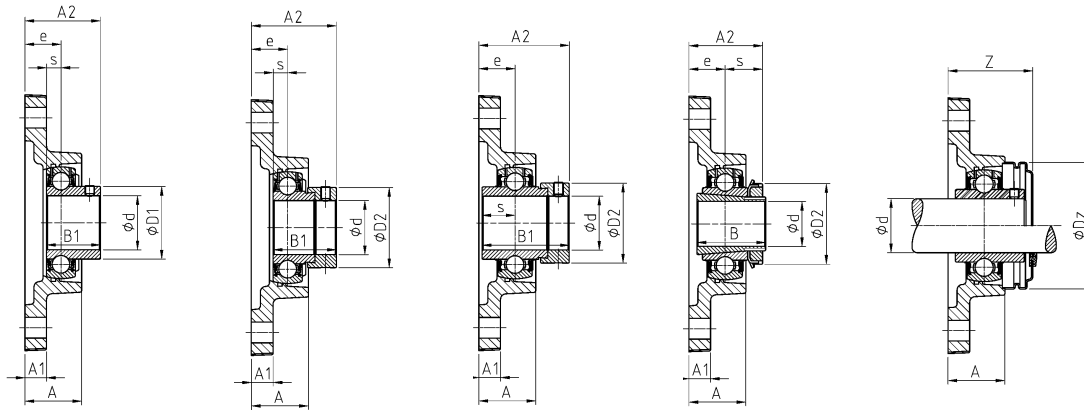

USFLE200

ESFLE200

EXFLE200

UKFLE200H

UCFLE200CO(CC)

Gehäuse
Einsatz
Schutzkappe
offen *
Schutzkappe
geschlossen **
Tragzahl
dyn.
Tragzahl
stat.
Gewicht
Wellendurch-
messer

G	Z	Dz						C_r [kN]	C_{or} [kN]	[kg]	d [mm]
R1/8"	41,8	54,0	FLE204	UC201	CO	CC		12,80	6,65	0,5	12
R1/8"	41,8	46,0	FLE203	US201	CO	CC		9,55	4,78	0,4	
R1/8"	***	***	FLE203	ES201	***	***		9,55	4,78	0,4	
R1/8"	***	***	FLE204	EX201	***	***		12,80	6,65	0,6	
R1/8"	41,8	54,0	FLE204	UC202	CO	CC		12,80	6,65	0,5	15
R1/8"	41,8	46,0	FLE203	US202	CO	CC		9,55	4,78	0,4	
R1/8"	***	***	FLE203	ES202	***	***		9,55	4,78	0,4	
R1/8"	***	***	FLE204	EX202	***	***		12,80	6,65	0,6	
R1/8"	41,8	54,0	FLE204	UC203	CO	CC		12,80	6,65	0,5	17
R1/8"	41,8	46,0	FLE203	US203	CO	CC		9,55	4,78	0,4	
R1/8"	***	***	FLE203	ES203	***	***		9,55	4,78	0,4	
R1/8"	***	***	FLE204	EX203	***	***		12,80	6,65	0,6	
R1/8"	41,8	54,0	FLE204	UC204	CO	CC		12,80	6,65	0,5	20
R1/8"	41,8	54,0	FLE204	US204	CO	CC		12,80	6,65	0,4	
R1/8"	***	***	FLE204	ES204	***	***		12,80	6,65	0,5	
R1/8"	***	***	FLE204	EX204	***	***		12,80	6,65	0,5	
R1/8"	43,9	60,0	FLE205	UK205 + H2305	CO	CC		14,00	7,88	0,6	
R1/8"	43,9	60,0	FLE205	UC205	CO	CC		14,00	7,88	0,6	25
R1/8"	43,9	60,0	FLE205	US205	CO	CC		14,00	7,88	0,6	
R1/8"	***	***	FLE205	ES205	***	***		14,00	7,88	0,6	
R1/8"	***	***	FLE205	EX205	***	***		14,00	7,88	0,7	
R1/8"	46,9	70,0	FLE206	UK206 + H2306	CO	CC		19,50	11,20	0,9	
R1/8"	46,9	70,0	FLE206	UC206	CO	CC		19,50	11,20	0,8	30
R1/8"	46,9	70,0	FLE206	US206	CO	CC		19,50	11,20	0,8	
R1/8"	***	***	FLE206	ES206	***	***		19,50	11,20	0,9	
R1/8"	***	***	FLE206	EX206	***	***		19,50	11,20	0,9	
R1/8"	50,2	80,0	FLE207	UK207 + H2307	CO	CC		25,70	15,20	1,2	
R1/8"	50,2	80,0	FLE207	UC207	CO	CC		25,70	15,20	1,1	35
R1/8"	50,2	80,0	FLE207	US207	CO	CC		25,70	15,20	1,1	
R1/8"	***	***	FLE207	ES207	***	***		25,70	15,20	1,2	
R1/8"	***	***	FLE207	EX207	***	***		25,70	15,20	1,3	
R1/8"	57,9	88,0	FLE208	UK208 + H2308	CO	CC		29,60	18,20	1,7	
R1/8"	57,9	88,0	FLE208	UC208	CO	CC		29,60	18,20	1,6	40
R1/8"	57,9	88,0	FLE208	US208	CO	CC		29,60	18,20	1,6	
R1/8"	***	***	FLE208	ES208	***	***		29,60	18,20	1,6	
R1/8"	***	***	FLE208	EX208	***	***		29,60	18,20	1,8	
R1/8"	58,4	95,0	FLE209	UK209 + H2309	CO	CC		31,85	20,80	1,9	

* = mit einer offenen Schutzkappe für durchgehende Wellen: Nachsetzzeichen CO wie Bestellbeispiel Seite 6

** = mit einer geschlossenen Schutzkappe für Wellenenden: Nachsetzzeichen CC wie Bestellbeispiel Seite 6

*** = mit Schutzkappen für Einsätze mit Excentering auf Anfrage lieferbar



Gehäuse FLE200 nachschmierbar

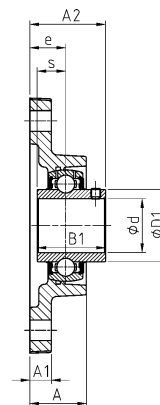
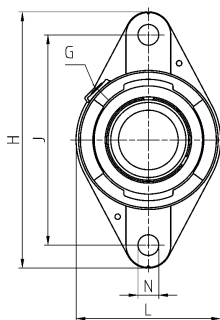
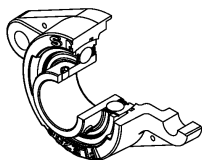

UCFLE200

Wellendurchmesser		Einheit		Hauptabmessungen in mm												
d [mm]		L	H	J	A	A1	A2	e	N	s1	B	B1	s	D1	D2	
45	UCFLE209	111	180	148,5	37,5	13,0	54,2	24	14,0	-	-	49,2	19,0	57,2	-	
	USFLE209	111	180	148,5	37,5	13,0	55,0	24	14,0	-	-	41,2	10,2	57,2	-	
	ESFLE209	111	180	148,5	37,5	13,0	56,7	24	14,0	-	-	43,7	11,0	-	63,5	
	EXFLE209	111	180	148,5	37,5	13,0	58,9	24	14,0	-	-	56,3	21,4	-	63,5	
	UKFLE210H	116	190	157,0	41,6	13,0	55,5	28	18,0	27,5	55,0	-	-	-	70,0	
50	UCFLE210	116	190	157,0	41,6	13,0	60,6	28	18,0	-	-	51,6	19,0	61,8	-	
	USFLE210	116	190	157,0	41,6	13,0	60,6	28	18,0	-	-	43,5	10,9	61,8	-	
	ESFLE210	116	190	157,0	41,6	13,0	60,7	28	18,0	-	-	43,7	11,0	-	69,9	
	EXFLE210	116	190	157,0	41,6	13,0	66,1	28	18,0	-	-	62,7	24,6	-	69,9	
	UKFLE211H	134	222	184,0	45,8	15,0	60,0	31	18,0	29,0	59,0	-	-	-	75,0	
55	UCFLE211	134	222	184,0	45,8	15,0	64,4	31	18,0	-	-	55,6	22,2	69,0	-	
	USFLE211	134	222	184,0	45,8	15,0	64,5	31	18,0	-	-	45,3	11,8	69,0	-	
	ESFLE211	134	222	184,0	45,8	15,0	67,4	31	18,0	-	-	48,4	12,0	-	76,2	
	EXFLE211	134	222	184,0	45,8	15,0	74,6	31	18,0	-	-	71,3	27,7	-	76,2	
	UKFLE212H	138	238	202,0	50,4	16,0	65,0	34	18,0	31,0	62,0	-	-	-	80,0	
60	UCFLE212	138	238	202,0	50,4	16,0	73,7	34	18,0	-	-	65,1	25,4	74,9	-	
	USFLE212	138	238	202,0	50,4	16,0	72,8	34	18,0	-	-	53,7	14,9	74,9	-	
	ESFLE212	138	238	202,0	50,4	16,0	71,3	34	18,0	-	-	49,3	12,0	-	84,2	
	EXFLE212	138	238	202,0	50,4	16,0	80,8	34	18,0	-	-	77,7	30,9	-	84,2	
	UKFLE213H	160	258	216,0	57,0	18,0	70,0	38	21,0	32,0	65,0	-	-	-	85,0	
65	UCFLE213	160	258	216,0	57,0	18,0	77,7	38	21,0	-	-	65,1	25,4	82,0	-	
	EXFLE213	160	258	216,0	57,0	18,0	89,6	38	21,0	-	-	85,7	34,1	-	86,0	
	UKFLE215H	160	258	216,0	57,0	18,0	73,5	38	21,0	35,5	73,0	-	-	-	98,0	
70	UCFLE214	160	258	216,0	57,0	18,0	82,4	38	21,0	-	-	74,6	30,2	86,5	-	
	EXFLE214	160	258	216,0	57,0	18,0	89,6	38	21,0	-	-	85,7	34,1	-	96,8	
75	UCFLE215	160	258	216,0	57,0	18,0	82,5	38	21,0	-	-	77,8	33,3	91,5	-	
	EXFLE215	160	258	216,0	57,0	18,0	92,8	38	21,0	-	-	92,1	37,3	-	102,0	

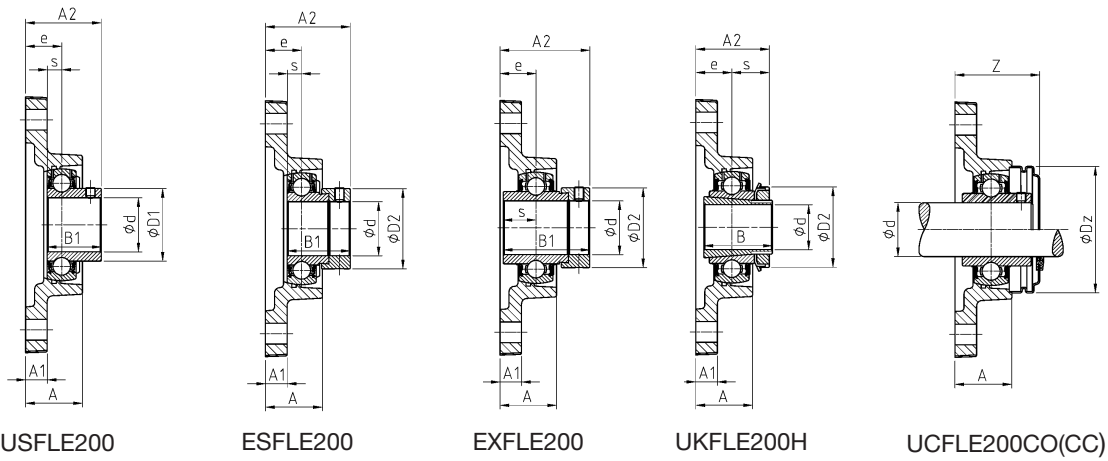

USFLE200

ESFLE200

EXFLE200

UKFLE200H

UCFLE200CO(CC)

G	Z	Dz	Gehäuse		Einsatz		Schutzkappe offen *		Schutzkappe geschlossen **		Tragzahl dyn.	Tragzahl stat.	Gewicht	Wellendurch- messer
			FLE209	UC209	CO	CC	C _r [kN]	C _{or} [kN]	[kg]	d [mm]				
R1/8"	58,4	95,0	FLE209	UC209	CO	CC	31,85	20,80	1,8	45				
R1/8"	58,4	95,0	FLE209	US209	CO	CC	31,85	20,80	1,8	45				
R1/8"	***	***	FLE209	ES209	***	***	31,85	20,80	1,8	45				
R1/8"	***	***	FLE209	EX209	***	***	31,85	20,80	2,0	45				
R1/8"	65,8	100,0	FLE210	UK210 + H2310	CO	CC	35,10	23,20	2,3	50				
R1/8"	65,8	100,0	FLE210	UC210	CO	CC	35,10	23,20	2,1	50				
R1/8"	65,8	100,0	FLE210	US210	CO	CC	35,10	23,20	2,1	50				
R1/8"	***	***	FLE210	ES210	***	***	35,10	23,20	2,1	50				
R1/8"	***	***	FLE210	EX210	***	***	35,10	23,20	2,3	50				
R1/8"	69,1	110,0	FLE211	UK211 + H2311	CO	CC	43,55	29,20	3,5	55				
R1/8"	69,1	110,0	FLE211	UC211	CO	CC	43,55	29,20	3,4	55				
R1/8"	69,1	110,0	FLE211	US211	CO	CC	43,55	29,20	3,4	55				
R1/8"	***	***	FLE211	ES211	***	***	43,55	29,20	3,2	55				
R1/8"	***	***	FLE211	EX211	***	***	43,55	29,20	3,7	55				
R1/8"	82,4	120,0	FLE212	UK212 + H2312	CO	CC	52,50	32,80	3,7	60				
R1/8"	82,4	120,0	FLE212	UC212	CO	CC	52,50	32,80	3,7	60				
R1/8"	82,4	120,0	FLE212	US212	CO	CC	52,50	32,80	3,5	60				
R1/8"	***	***	FLE212	ES212	***	***	52,50	32,80	3,4	60				
R1/8"	***	***	FLE212	EX212	***	***	52,50	32,80	4,0	60				
R1/8"	82,9	132,0	FLE213	UK213 + H2313	CO	CC	57,20	40,00	4,1	65				
R1/8"	82,9	132,0	FLE213	UC213	CO	CC	57,20	40,00	4,0	65				
R1/8"	***	***	FLE213	EX213	***	***	57,20	40,00	4,6	65				
R1/8"	-	-	FLE215	UK215 + H2315	-	-	66,00	49,50	4,9	70				
R1/8"	-	-	FLE214	UC214	-	-	62,00	45,00	5,4	70				
R1/8"	-	-	FLE214	EX214	-	-	62,00	45,00	5,9	70				
R1/8"	-	-	FLE215	UC215	-	-	66,00	49,50	5,2	75				
R1/8"	-	-	FLE215	EX215	-	-	66,00	49,50	5,8	75				

* = mit einer offenen Schutzkappe für durchgehende Wellen: Nachsetzzeichen CO wie Bestellbeispiel Seite 6

** = mit einer geschlossenen Schutzkappe für Wellenenden: Nachsetzzeichen CC wie Bestellbeispiel Seite 6

*** = mit Schutzkappen für Einsätze mit Excenterring auf Anfrage lieferbar

Gehäuse

FL200 nachschmierbar
FL300 nachschmierbar

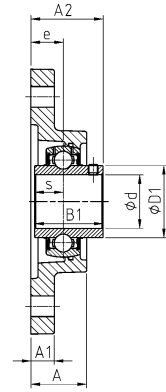
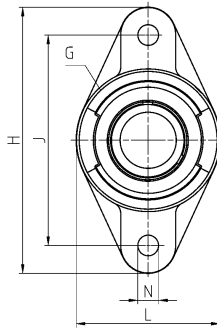
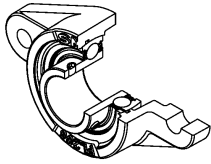

UCFL200
UCFL300

Wellendurchmesser
Einheit

Hauptabmessungen in mm

d [mm]		L	H	J	A	A1	A2	e	N	s1	B	B1	s	D1	D2
12	UCFL201	60	113	90,0	25,5	11	33,3	15	12	-	-	31,0	12,7	29,0	-
	USFL201	57	99	76,5	25,5	11	31,0	15	12	-	-	22,0	6,0	24,6	-
	ESFL201	57	99	76,5	25,5	11	37,1	15	12	-	-	28,6	6,5	-	28,6
	EXFL201	60	113	90,0	25,5	11	41,5	15	12	-	-	43,5	17,0	-	33,3
15	UCFL202	60	113	90,0	25,5	11	33,3	15	12	-	-	31,0	12,7	29,0	-
	USFL202	57	99	76,5	25,5	11	31,0	15	12	-	-	22,0	6,0	24,6	-
	ESFL202	57	99	76,5	25,5	11	37,1	15	12	-	-	28,6	6,5	-	28,6
	EXFL202	60	113	90,0	25,5	11	41,5	15	12	-	-	43,5	17,0	-	33,3
17	UCFL203	60	113	90,0	25,5	11	33,3	15	12	-	-	31,0	12,7	29,0	-
	USFL203	57	99	76,5	25,5	11	31,0	15	12	-	-	22,0	6,0	24,6	-
	ESFL203	57	99	76,5	25,5	11	37,1	15	12	-	-	28,6	6,5	-	28,6
	EXFL203	60	113	90,0	25,5	11	41,5	15	12	-	-	43,5	17,0	-	33,3
20	UCFL204	60	113	90,0	25,5	11	33,3	15	12	-	-	31,0	12,7	29,0	-
	USFL204	60	113	90,0	25,5	11	33,0	15	12	-	-	25,0	7,0	29,0	-
	ESFL204	60	113	90,0	25,5	11	38,4	15	12	-	-	30,9	7,5	-	33,3
	EXFL204	60	113	90,0	25,5	11	41,5	15	12	-	-	43,5	17,0	-	33,3
	UKFL205H	68	130	99,0	27,0	13	34,5	16	16	18,5	35,0	-	-	-	38,0
	UKFL305H	80	150	113,0	29,0	13	37,5	16	19	21,5	35,0	-	-	-	38,0
25	UCFL205	68	130	99,0	27,0	13	35,7	16	16	-	-	34,0	14,3	34,0	-
	USFL205	68	130	99,0	27,0	13	35,5	16	16	-	-	27,0	7,5	34,0	-
	ESFL205	68	130	99,0	27,0	13	39,4	16	16	-	-	30,9	7,5	-	38,1
	EXFL205	68	130	99,0	27,0	13	42,9	16	16	-	-	44,3	17,4	-	38,1
	UKFL206H	80	148	117,0	31,0	13	38,5	18	16	20,5	38,0	-	-	-	45,0
	UCFL305	80	150	113,0	29,0	13	39,0	16	19	-	-	38,0	15,0	35,4	-
	EXFL305	80	150	113,0	29,0	13	46,1	16	19	-	-	46,8	16,7	-	42,8
	UKFL306H	90	180	134,0	32,0	15	41,0	18	23	23,0	38,0	-	-	-	45,0
30	UCFL206	80	148	117,0	31,0	13	40,2	18	16	-	-	38,1	15,9	40,3	-
	USFL206	80	148	117,0	31,0	13	40,0	18	16	-	-	30,0	8,0	40,3	-
	ESFL206	80	148	117,0	31,0	13	44,7	18	16	-	-	35,7	9,0	-	44,5
	EXFL206	80	148	117,0	31,0	13	48,1	18	16	-	-	48,3	18,2	-	44,5
	UKFL207H	90	161	130,0	34,0	14	41,5	19	16	22,5	43,0	-	-	-	52,0
	UCFL306	90	180	134,0	32,0	15	44,0	18	23	-	-	43,0	17,0	44,6	-
	EXFL306	90	180	134,0	32,0	15	50,5	18	23	-	-	50,0	17,5	-	50,0
	UKFL307H	100	185	141,0	36,0	16	45,5	20	23	25,5	43,0	-	-	-	52,0

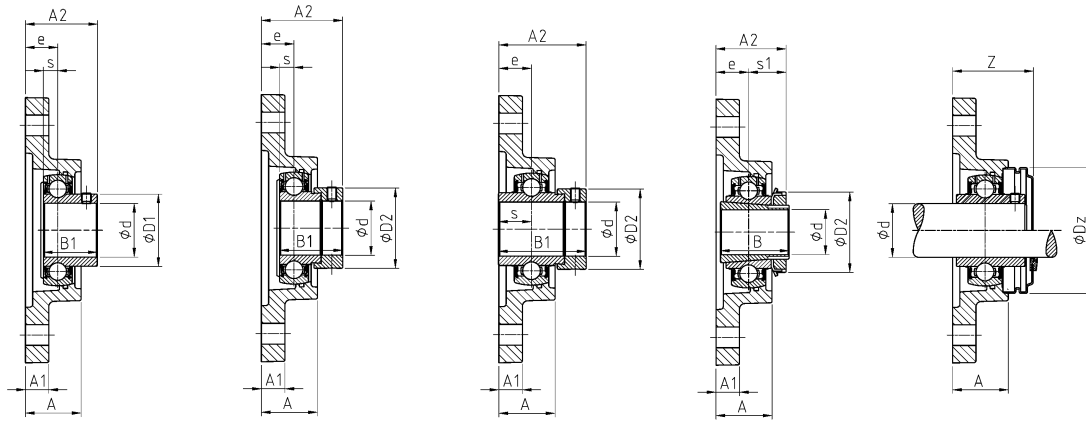

USFL200

ESFL200

EXFL200
EXFL300UKFL200H
UKFL300H

UCFL200CO(CC)

Gehäuse

Einsatz

Schutzkappe
offen *Schutzkappe
geschlossen **Tragzahl
dyn.Tragzahl
stat.

Gewicht

Wellendurch-
messer

G	Z	Dz					C _r [kN]	C _{0r} [kN]	[kg]	d [mm]
M6x1	36,5	54,0	FL204	UC201	CO	CC	12,80	6,65	0,5	12
M6x1	35,8	46,0	FL203	US201	CO	CC	9,55	4,78	0,4	
M6x1	***	***	FL203	ES201	***	***	9,55	4,78	0,4	
M6x1	***	***	FL204	EX201	***	***	12,80	6,65	0,6	
M6x1	36,5	54,0	FL204	UC202	CO	CC	12,80	6,65	0,5	15
M6x1	35,8	46,0	FL203	US202	CO	CC	9,55	4,78	0,3	
M6x1	***	***	FL203	ES202	***	***	9,55	4,78	0,4	
M6x1	***	***	FL204	EX202	***	***	12,80	6,65	0,5	
M6x1	36,5	54,0	FL204	UC203	CO	CC	12,80	6,65	0,4	17
M6x1	35,8	46,0	FL203	US203	CO	CC	9,55	4,78	0,4	
M6x1	***	***	FL203	ES203	***	***	9,55	4,78	0,4	
M6x1	***	***	FL204	EX203	***	***	12,80	6,65	0,5	
M6x1	36,5	54,0	FL204	UC204	CO	CC	12,80	6,65	0,4	20
M6x1	36,5	54,0	FL204	US204	CO	CC	12,80	6,65	0,4	
M6x1	***	***	FL204	ES204	***	***	12,80	6,65	0,4	
M6x1	***	***	FL204	EX204	***	***	12,80	6,65	0,5	
M6x1	39,1	60,0	FL205	UK205 + H2305	CO	CC	14,00	7,88	0,7	25
M6x1	-	-	FL305	UK305 + H2305	-	-	22,36	11,50	1,1	
M6x1	39,1	60,0	FL205	UC205	CO	CC	14,00	7,88	0,6	
M6x1	39,1	60,0	FL205	US205	CO	CC	14,00	7,88	0,6	
M6x1	***	***	FL205	ES205	***	***	14,00	7,88	0,6	25
M6x1	***	***	FL205	EX205	***	***	14,00	7,88	0,7	
M6x1	45,2	70,0	FL206	UK206 + H2306	CO	CC	19,50	11,20	1,0	
M6x1	-	-	FL305	UC305	-	-	22,36	11,50	0,9	
M6x1	-	-	FL305	EX305	-	-	22,36	11,50	1,0	30
M6x1	-	-	FL306	UK306 + H2306	-	-	27,00	15,20	1,4	
M6x1	45,2	70,0	FL206	UC206	CO	CC	19,50	11,20	0,9	
M6x1	45,2	70,0	FL206	US206	CO	CC	19,50	11,20	0,9	
M6x1	***	***	FL206	ES206	***	***	19,50	11,20	0,9	30
M6x1	***	***	FL206	EX206	***	***	19,50	11,20	1,0	
M6x1	48,2	80,0	FL207	UK207 + H2307	CO	CC	25,70	15,20	1,2	
M6x1	-	-	FL306	UC306	-	-	27,00	15,20	1,4	
M6x1	-	-	FL306	EX306	-	-	27,00	15,20	1,5	30
M6x1	-	-	FL307	UK307 + H2307	-	-	33,50	19,20	1,9	

* = mit einer offenen Schutzkappe für durchgehende Wellen: Nachsetzzeichen CO wie Bestellbeispiel Seite 6

** = mit einer geschlossenen Schutzkappe für Wellenenden: Nachsetzzeichen CC wie Bestellbeispiel Seite 6

*** = mit Schutzkappen für Einsätze mit Excenterring auf Anfrage lieferbar

Gehäuse

FL200 nachschmierbar
FL300 nachschmierbar

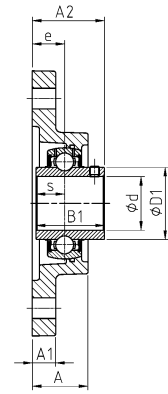
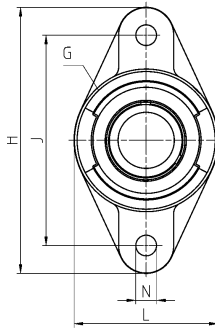
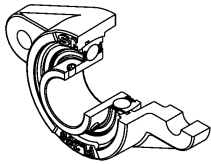

UCFL200
UCFL300

Wellendurchmesser		Einheit		Hauptabmessungen in mm												
d [mm]		L	H	J	A	A1	A2	e	N	s1	B	B1	s	D1	D2	
35	UCFL207	90	161	130,0	34,0	14	44,4	19	16	-	-	42,9	17,5	48,0	-	
	USFL207	90	161	130,0	34,0	14	42,5	19	16	-	-	32,0	8,5	48,0	-	
	ESFL207	90	161	130,0	34,0	14	48,4	19	16	-	-	38,9	9,5	-	55,6	
	EXFL207	90	161	130,0	34,0	14	51,3	19	16	-	-	51,1	18,8	-	55,6	
	UKFL208H	100	175	144,0	36,0	14	45,5	21	16	24,5	46,0	-	-	-	58,0	
	UCFL307	100	185	141,0	36,0	16	49,0	20	23	-	-	48,0	19,0	48,9	-	
	EXFL307	100	185	141,0	36,0	16	53,3	20	23	-	-	51,6	18,3	-	55,0	
	UKFL308H	112	200	158,0	40,0	17	50,5	23	23	27,5	46,0	-	-	-	58,0	
40	UCFL208	100	175	144,0	36,0	14	51,2	21	16	-	-	49,2	19,0	53,0	-	
	USFL208	100	175	144,0	36,0	14	46,0	21	16	-	-	34,0	9,0	53,0	-	
	ESFL208	100	175	144,0	36,0	14	53,7	21	16	-	-	43,7	11,0	-	60,3	
	EXFL208	100	175	144,0	36,0	14	55,9	21	16	-	-	56,3	21,4	-	60,3	
	UKFL209H	108	188	148,0	38,0	16	48,0	22	19	26,0	50,0	-	-	-	65,0	
	UCFL308	112	200	158,0	40,0	17	56,0	23	23	-	-	52,0	19,0	56,5	-	
	EXFL308	112	200	158,0	40,0	17	60,3	23	23	-	-	57,1	19,8	-	63,5	
	UKFL309H	125	230	177,0	44,0	18	55,0	25	25	30,0	50,0	-	-	-	65,0	
45	UCFL209	108	188	148,0	38,0	16	52,2	22	19	-	-	49,2	19,0	57,2	-	
	USFL209	108	188	148,0	38,0	16	53,0	22	19	-	-	41,2	10,2	57,2	-	
	ESFL209	108	188	148,0	38,0	16	54,7	22	19	-	-	43,7	11,0	-	63,5	
	EXFL209	108	188	148,0	38,0	16	56,9	22	19	-	-	56,3	21,4	-	63,5	
	UKFL210H	115	197	157,0	40,0	16	49,5	22	19	27,5	55,0	-	-	-	70,0	
	UCFL309	125	230	177,0	44,0	18	60,0	25	25	-	-	57,0	22,0	61,8	-	
	EXFL309	125	230	177,0	44,0	18	63,9	25	25	-	-	58,7	19,8	-	70,0	
	UKFL310H	140	240	187,0	48,0	19	60,0	28	25	32,0	55,0	-	-	-	70,0	
50	UCFL210	115	197	157,0	40,0	16	54,6	22	19	-	-	51,6	19,0	61,8	-	
	USFL210	115	197	157,0	40,0	16	54,6	22	19	-	-	43,5	10,9	61,8	-	
	ESFL210	115	197	157,0	40,0	16	54,7	22	19	-	-	43,7	11,0	-	69,9	
	EXFL210	115	197	157,0	40,0	16	60,1	22	19	-	-	62,7	24,6	-	69,9	
	UKFL211H	130	224	184,0	43,0	18	54,0	25	19	29,0	59,0	-	-	-	75,0	
	UCFL310	140	240	187,0	48,0	19	67,0	28	25	-	-	61,0	22,0	68,7	-	
	EXFL310	140	240	187,0	48,0	19	70,0	28	25	-	-	66,6	24,6	-	76,2	
	UKFL311H	150	250	198,0	52,0	20	64,0	30	25	34,0	59,0	-	-	-	75,0	

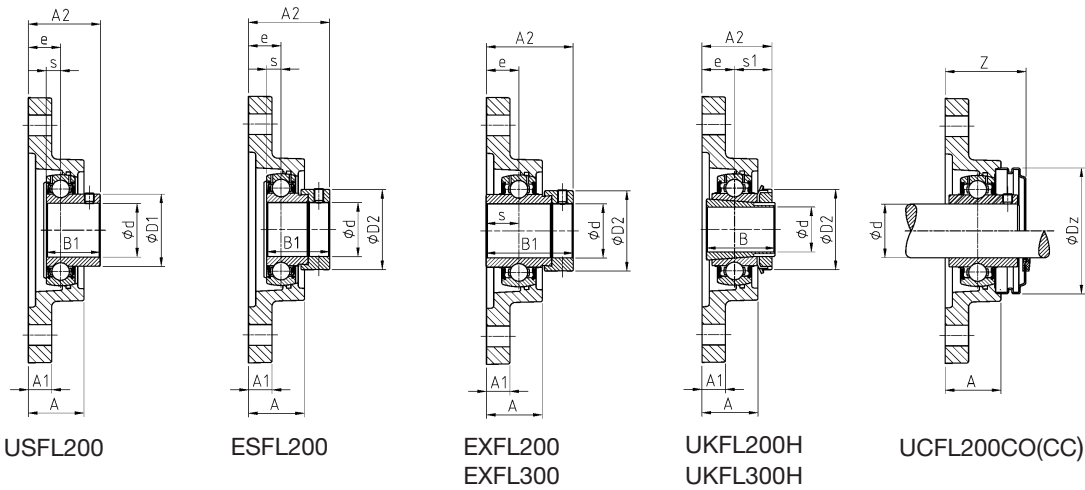

G	Z	Dz	Gehäuse		Einsatz		Schutzkappe offen *		Schutzkappe geschlossen **		Tragzahl dyn.	Tragzahl stat.	Gewicht	Wellendurch- messer
			FL	UC	CO	CC	C_r [kN]	C_{or} [kN]	[kg]	d [mm]				
M6x1	48,2	80,0	FL207	UC207	CO	CC	25,70	15,20	1,2	35				
M6x1	48,2	80,0	FL207	US207	CO	CC	25,70	15,20	1,1					
M6x1	***	***	FL207	ES207	***	***	25,70	15,20	1,2					
M6x1	***	***	FL207	EX207	***	***	25,70	15,20	1,3					
M6x1	55,1	88,0	FL208	UK208 + H2308	CO	CC	29,60	18,20	1,6					
M6x1	-	-	FL307	UC307	-	-	33,50	19,20	1,7					
M6x1	-	-	FL307	EX307	-	-	33,50	19,20	1,8					
M6x1	-	-	FL308	UK308 + H2308	-	-	40,56	24,00	2,3					
M6x1	55,1	88,0	FL208	UC208	CO	CC	29,60	18,20	1,5		40			
M6x1	55,1	88,0	FL208	US208	CO	CC	29,60	18,20	1,5					
M6x1	***	***	FL208	ES208	***	***	29,60	18,20	1,5					
M6x1	***	***	FL208	EX208	***	***	29,60	18,20	1,6					
M6x1	56,3	95,0	FL209	UK209 + H2309	CO	CC	31,85	20,80	2,0					
M6x1	-	-	FL308	UC308	-	-	40,56	24,00	2,2					
M6x1	-	-	FL308	EX308	-	-	40,56	24,00	2,3					
M6x1	-	-	FL309	UK309 + H2309	-	-	53,00	31,80	3,3					
M6x1	56,3	95,0	FL209	UC209	CO	CC	31,85	20,80	1,9	45				
M6x1	56,3	95,0	FL209	US209	CO	CC	31,85	20,80	1,8					
M6x1	***	***	FL209	ES209	***	***	31,85	20,80	1,9					
M6x1	***	***	FL209	EX209	***	***	31,85	20,80	2,1					
M6x1	60,1	100,0	FL210	UK210 + H2310	CO	CC	35,10	23,20	2,4					
M6x1	-	-	FL309	UC309	-	-	53,00	31,80	3,1					
M6x1	-	-	FL309	EX309	-	-	53,00	31,80	3,3					
M6x1	-	-	FL310	UK310 + H2310	-	-	62,00	37,80	4,1					
M6x1	60,1	100,0	FL210	UC210	CO	CC	35,10	23,20	2,2		50			
M6x1	60,1	100,0	FL210	US210	CO	CC	35,10	23,20	2,2					
M6x1	***	***	FL210	ES210	***	***	35,10	23,20	2,2					
M6x1	***	***	FL210	EX210	***	***	35,10	23,20	2,4					
M6x1	63,7	110,0	FL211	UK211 + H2311	CO	CC	43,55	29,20	3,1					
M6x1	-	-	FL310	UC310	-	-	62,00	37,80	4,0					
M6x1	-	-	FL310	EX310	-	-	62,00	37,80	4,2					
M6x1	-	-	FL311	UK311 + H2311	-	-	71,50	44,80	4,9					

* = mit einer offenen Schutzkappe für durchgehende Wellen: Nachsetzzeichen CO wie Bestellbeispiel Seite 6

** = mit einer geschlossenen Schutzkappe für Wellenenden: Nachsetzzeichen CC wie Bestellbeispiel Seite 6

*** = mit Schutzkappen für Einsätze mit Excenterring auf Anfrage lieferbar

Gehäuse **FL200 nachschmierbar**
FL300 nachschmierbar

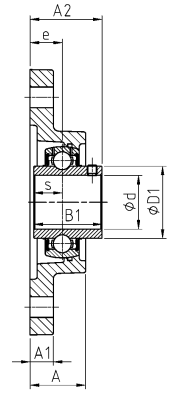
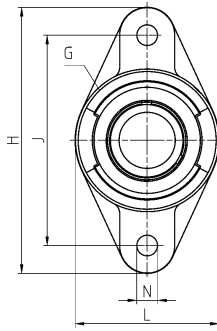
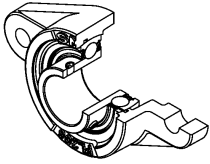

UCFL200
UCFL300

Wellendurchmesser		Einheit		Hauptabmessungen in mm												
d [mm]		L	H	J	A	A1	A2	e	N	s1	B	B1	s	D1	D2	
55	UCFL211	130	224	184,0	43,0	18	58,4	25	19	-	-	55,6	22,2	69,0	-	
	USFL211	130	224	184,0	43,0	18	58,5	25	19	-	-	45,3	11,8	69,0	-	
	ESFL211	130	224	184,0	43,0	18	61,4	25	19	-	-	48,4	12,0	-	76,2	
	EXFL211	130	224	184,0	43,0	18	68,6	25	19	-	-	71,3	27,7	-	76,2	
	UKFL212H	140	250	202,0	48,0	18	60,0	29	23	31,0	62,0	-	-	-	80,0	
	UCFL311	150	250	198,0	52,0	20	71,0	30	25	-	-	66,0	25,0	74,9	-	
	EXFL311	150	250	198,0	52,0	20	75,2	30	25	-	-	73,0	27,8	-	83,0	
	UKFL312H	160	270	212,0	56,0	22	69,5	33	31	36,5	62,0	-	-	-	80,0	
60	UCFL212	140	250	202,0	48,0	18	68,7	29	23	-	-	65,1	25,4	74,9	-	
	USFL212	140	250	202,0	48,0	18	67,8	29	23	-	-	53,7	14,9	74,9	-	
	ESFL212	140	250	202,0	48,0	18	66,3	29	23	-	-	49,3	12,0	-	84,2	
	EXFL212	140	250	202,0	48,0	18	75,8	29	23	-	-	77,7	30,9	-	84,2	
	UKFL213H	155	258	210,0	50,0	20	62,0	30	23	32,0	65,0	-	-	-	85,0	
	UCFL312	160	270	212,0	56,0	22	78,0	33	31	-	-	71,0	26,0	81,0	-	
	EXFL312	160	270	212,0	56,0	22	81,4	33	31	-	-	79,4	31,0	-	89,0	
	UKFL313H	175	295	240,0	58,0	25	71,5	33	31	38,5	65,0	-	-	-	85,0	
65	UCFL213	155	258	210,0	50,0	20	69,7	30	23	-	-	65,1	25,4	82,0	-	
	EXFL213	155	258	210,0	50,0	20	81,6	30	23	-	-	85,7	34,1	-	86,0	
	UKFL215H	164	275	225,0	55,0	22	69,5	34	23	35,5	73,0	-	-	-	98,0	
	UCFL313	175	295	240,0	58,0	25	78,0	33	31	-	-	75,0	30,0	87,5	-	
	EXFL313	175	295	240,0	58,0	25	86,2	33	31	-	-	85,7	32,5	-	97,0	
	UKFL315H	195	320	260,0	66,0	30	81,5	39	35	42,5	73,0	-	-	-	98,0	
70	UCFL214	160	265	216,0	54,0	20	75,4	31	23	-	-	74,6	30,2	86,5	-	
	EXFL214	160	265	216,0	54,0	20	82,6	31	23	-	-	85,7	34,1	-	96,8	
	UKFL216H	180	290	233,0	58,0	22	73,0	34	25	39,0	78,0	-	-	-	105,0	
	UCFL314	185	315	250,0	61,0	28	83,0	36	35	-	-	78,0	33,0	94,0	-	
	EXFL314	185	315	250,0	61,0	28	93,9	36	35	-	-	92,1	34,2	-	102,0	
	UKFL316H	210	355	285,0	68,0	32	82,5	38	38	44,5	78,0	-	-	-	105,0	
75	UCFL215	164	275	225,0	55,0	22	78,5	34	23	-	-	77,8	33,3	91,5	-	
	EXFL215	164	275	225,0	55,0	22	88,8	34	23	-	-	92,1	37,3	-	102,0	
	UKFL217H	190	305	248,0	63,0	22	76,0	36	25	40,0	82,0	-	-	-	110,0	
	UCFL315	195	320	260,0	66,0	30	89,0	39	35	-	-	82,0	32,0	100,5	-	
	EXFL315	195	320	260,0	66,0	30	101,7	39	35	-	-	100,0	37,3	-	113,0	
	UKFL317H	220	370	300,0	74,0	32	92,0	44	38	48,0	82,0	-	-	-	110,0	

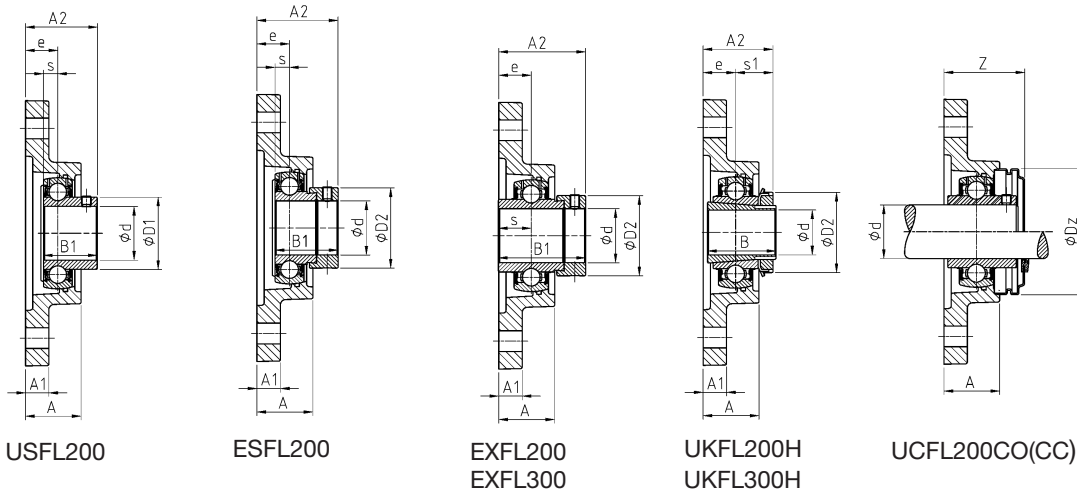

			Gehäuse	Einsatz	Schutzkappe offen *	Schutzkappe geschlossen **	Tragzahl dyn.	Tragzahl stat.	Gewicht	Wellendurch- messer
G	Z	Dz					C _r [kN]	C _{or} [kN]	[kg]	d [mm]
M6x1	63,7	110,0	FL211	UC211	CO	CC	43,55	29,20	3,0	55
M6x1	63,7	110,0	FL211	US211	CO	CC	43,55	29,20	2,9	
M6x1	***	***	FL211	ES211	***	***	43,55	29,20	2,7	
M6x1	***	***	FL211	EX211	***	***	43,55	29,20	3,3	
M6x1	74,0	120,0	FL212	UK212 + H2312	CO	CC	52,50	32,80	3,8	60
M6x1	-	-	FL311	UC311	-	-	71,50	44,80	4,6	
M6x1	-	-	FL311	EX311	-	-	71,50	44,80	5,0	
M6x1	-	-	FL312	UK312 + H2312	-	-	81,60	51,80	5,7	
M6x1	74,0	120,0	FL212	UC212	CO	CC	52,50	32,80	3,9	60
M6x1	74,0	120,0	FL212	US212	CO	CC	52,50	32,80	3,6	
M6x1	***	***	FL212	ES212	***	***	52,50	32,80	3,5	
M6x1	***	***	FL212	EX212	***	***	52,50	32,80	4,2	
M6x1	74,3	132,0	FL213	UK213 + H2313	CO	CC	57,20	40,00	4,8	65
M6x1	-	-	FL312	UC312	-	-	81,60	51,80	5,8	
M6x1	-	-	FL312	EX312	-	-	81,60	51,80	6,1	
M6x1	-	-	FL313	UK313 + H2313	-	-	93,86	60,50	7,4	
M6x1	74,3	132,0	FL213	UC213	CO	CC	57,20	40,00	4,8	65
M6x1	***	***	FL213	EX213	***	***	57,20	40,00	5,3	
M10x1	-	-	FL215	UK215 + H2315	-	-	66,00	49,50	5,7	
M6x1	-	-	FL313	UC313	-	-	93,86	60,50	7,3	
M6x1	-	-	FL313	EX313	-	-	93,86	60,50	7,8	70
M10x1	-	-	FL315	UK315 + H2315	-	-	113,36	76,80	10,2	
M10x1	-	-	FL214	UC214	-	-	62,00	45,00	5,4	
M10x1	-	-	FL214	EX214	-	-	62,00	45,00	5,9	
M10x1	-	-	FL216	UK216 + H2316	-	-	72,50	54,20	7,5	70
M10x1	-	-	FL314	UC314	-	-	104,26	68,00	8,7	
M10x1	-	-	FL314	EX314	-	-	104,26	68,00	9,3	
M10x1	-	-	FL316	UK316 + H2316	-	-	122,85	86,50	12,8	
M10x1	-	-	FL215	UC215	-	-	66,00	49,50	5,4	75
M10x1	-	-	FL215	EX215	-	-	66,00	49,50	6,0	
M10x1	-	-	FL217	UK217 + H2317	-	-	83,20	63,80	9,0	
M10x1	-	-	FL315	UC315	-	-	113,36	76,80	9,5	
M10x1	-	-	FL315	EX315	-	-	113,36	76,80	10,6	
M10x1	-	-	FL317	UK317 + H2317	-	-	132,60	96,50	14,4	

* = mit einer offenen Schutzkappe für durchgehende Wellen: Nachsetzzeichen CO wie Bestellbeispiel Seite 6
 ** = mit einer geschlossenen Schutzkappe für Wellenenden: Nachsetzzeichen CC wie Bestellbeispiel Seite 6
 *** = mit Schutzkappen für Einsätze mit Excentering auf Anfrage lieferbar



Gehäuse **FL200 nachschmierbar**
FL300 nachschmierbar

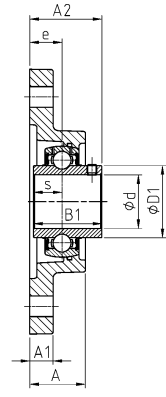
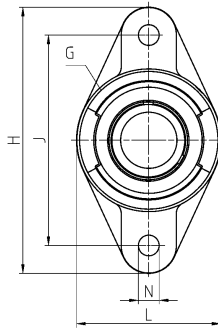
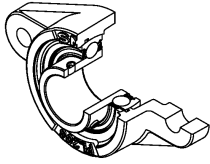

UCFL200
UCFL300

Wellendurchmesser		Einheit		Hauptabmessungen in mm												
d [mm]		L	H	J	A	A1	A2	e	N	s1	B	B1	s	D1	D2	
80	UCFL216	180	290	233,0	58,0	22	83,3	34	25	-	-	82,6	33,3	98,0	-	
	EXFL216	180	290	233,0	58,0	22	91,9	34	25	-	-	95,2	37,3	-	110,0	
	UKFL218H	205	320	265,0	68,0	23	82,0	40	25	42,0	86,0	-	-	-	120,0	
	UCFL316	210	355	285,0	68,0	32	90,0	38	38	-	-	86,0	34,0	107,9	-	
	EXFL316	210	355	285,0	68,0	32	103,9	38	38	-	-	106,4	40,5	-	119,0	
	UKFL318H	235	385	315,0	76,0	36	92,0	44	38	48,0	86,0	-	-	-	120,0	
85	UCFL217	190	305	248,0	63,0	22	87,6	36	25	-	-	85,7	34,1	105,1	-	
	EXFL217	190	305	248,0	63,0	22	83,6	36	25	-	-	73,2	23,4	-	119,0	
	UCFL317	220	370	300,0	74,0	32	100,0	44	38	-	-	96,0	40,0	114,0	-	
	EXFL317	220	370	300,0	74,0	32	111,5	44	38	-	-	109,5	42,0	-	127,0	
	UKFL319H	250	405	330,0	94,0	40	111,0	59	41	52,0	90,0	-	-	-	125,0	
90	UCFL218	205	320	265,0	68,0	23	96,3	40	25	-	-	96,0	39,7	111,0	-	
	EXFL218	205	320	265,0	68,0	23	86,5	40	25	-	-	72,5	24,5	-	120,0	
	UCFL318	235	385	315,0	76,0	36	100,0	44	38	-	-	96,0	40,0	120,0	-	
	EXFL318	235	385	315,0	76,0	36	116,3	44	38	-	-	115,9	43,6	-	133,0	
	UKFL320H	270	440	360,0	94,0	40	113,0	59	44	54,0	97,0	-	-	-	130,0	
95	UCFL319	250	405	330,0	94,0	40	121,0	59	41	-	-	103,0	41,0	126,5	-	
	EXFL319	250	405	330,0	94,0	40	134,5	59	41	-	-	122,3	46,8	-	140,0	
100	UCFL320	270	440	360,0	94,0	40	125,0	59	44	-	-	108,0	42,0	134,5	-	
	EXFL320	270	440	360,0	94,0	40	137,6	59	44	-	-	128,6	50,0	-	146,0	
	UKFL322H	300	470	390,0	96,0	42	121,0	60	44	61,0	105,0	-	-	-	145,0	
105	UCFL321	270	440	360,0	94,0	40	127,0	59	44	-	-	112,0	44,0	140,5	-	
110	UCFL322	300	470	390,0	96,0	42	131,0	60	44	-	-	117,0	46,0	149,0	-	
	UKFL324H	330	520	430,0	110,0	48	130,0	65	47	65,0	112,0	-	-	-	155,0	
115	UKFL326H	360	550	460,0	115,0	50	134,0	65	47	69,0	121,0	-	-	-	165,0	
120	UCFL324	330	520	430,0	110,0	48	140,0	65	47	-	-	126,0	51,0	163,0	-	
125	UKFL328H	400	600	500,0	125,0	60	148,0	75	51	73,0	131,0	-	-	-	180,0	
130	UCFL326	360	550	460,0	115,0	50	146,0	65	47	-	-	135,0	54,0	177,0	-	
140	UCFL328	400	600	500,0	125,0	60	161,0	75	51	-	-	145,0	59,0	190,0	-	

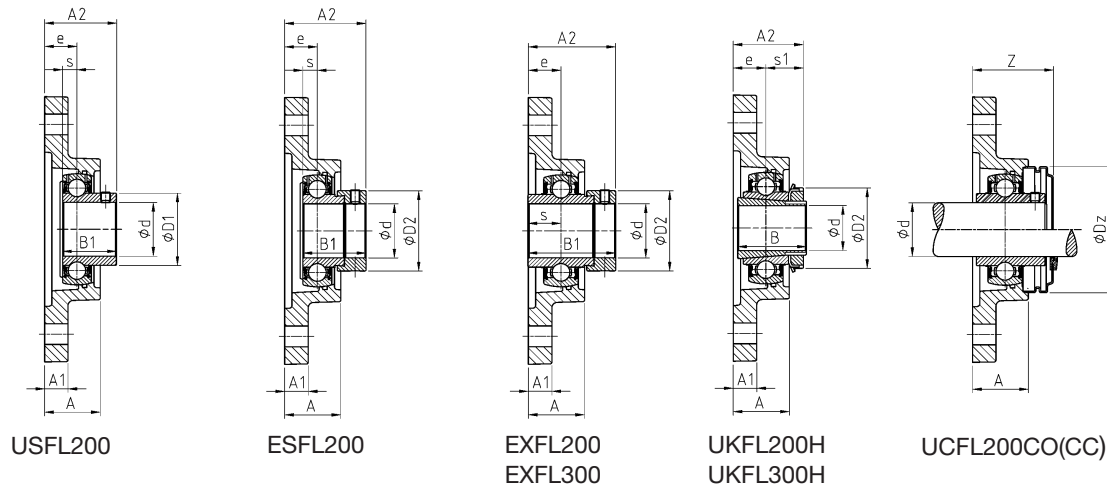

USFL200

ESFL200

EXFL200
EXFL300UKFL200H
UKFL300H

UCFL200CO(CC)

Gehäuse

Einsatz

Schutzkappe
offen *Schutzkappe
geschlossen **Tragzahl
dyn.Tragzahl
stat.

Gewicht

Wellendurch-
messer

G	Z	Dz				C_r [kN]	C_{or} [kN]	[kg]	d [mm]
M10x1	-	-	FL216	UC216	-	72,50	54,20	7,1	80
M10x1	-	-	FL216	EX216	-	72,50	54,20	7,4	80
M10x1	-	-	FL218	UK218 + H2318	-	96,00	71,50	11,2	80
M10x1	-	-	FL316	UC316	-	122,85	86,50	12,5	80
M10x1	-	-	FL316	EX316	-	122,85	86,50	13,6	80
M10x1	-	-	FL318	UK318 + H2318	-	143,00	108,00	17,1	80
M10x1	-	-	FL217	UC217	-	83,20	63,80	8,5	85
M10x1	-	-	FL217	EX217	-	83,20	63,80	8,9	85
M10x1	-	-	FL317	UC317	-	132,60	96,50	14,4	85
M10x1	-	-	FL317	EX317	-	132,60	96,50	15,5	85
M10x1	-	-	FL319	UK319 + H2319	-	156,00	122,00	21,6	85
M10x1	-	-	FL218	UC218	-	96,00	71,50	10,9	90
M10x1	-	-	FL218	EX218	-	96,00	71,50	11,4	90
M10x1	-	-	FL318	UC318	-	143,00	108,00	17,0	90
M10x1	-	-	FL318	EX318	-	143,00	108,00	18,3	90
M10x1	-	-	FL320	UK320 + H2320	-	171,60	140,00	25,9	90
M10x1	-	-	FL319	UC319	-	156,00	122,00	21,3	95
M10x1	-	-	FL319	EX319	-	156,00	122,00	22,8	95
M10x1	-	-	FL320	UC320	-	171,60	140,00	26,1	100
M10x1	-	-	FL320	EX320	-	171,60	140,00	27,9	100
M10x1	-	-	FL322	UK322 + H2322	-	205,00	178,00	35,9	100
M10x1	-	-	FL321	UC321	-	182,00	155,00	25,0	105
M10x1	-	-	FL322	UC322	-	205,00	178,00	32,6	110
M10x1	-	-	FL324	UK324 + H2324	-	228,00	208,00	47,7	110
M10x1	-	-	FL326	UK326 + H2326	-	252,00	242,00	61,3	115
M10x1	-	-	FL324	UC324	-	228,00	208,00	45,0	120
M10x1	-	-	FL328	UK328 + H2328	-	275,00	272,00	83,6	125
M10x1	-	-	FL326	UC326	-	252,00	242,00	56,4	130
M10x1	-	-	FL328	UC328	-	275,00	272,00	77,6	140

* = mit einer offenen Schutzkappe für durchgehende Wellen: Nachsetzzeichen CO wie Bestellbeispiel Seite 6

** = mit einer geschlossenen Schutzkappe für Wellenenden: Nachsetzzeichen CC wie Bestellbeispiel Seite 6

*** = mit Schutzkappen für Einsätze mit Excenterring auf Anfrage lieferbar

Gehäuse **FLZ200 nachschmierbar**

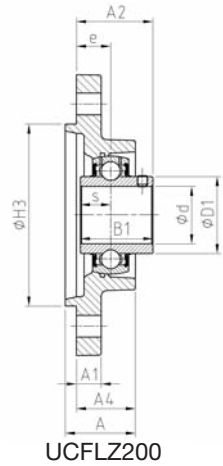
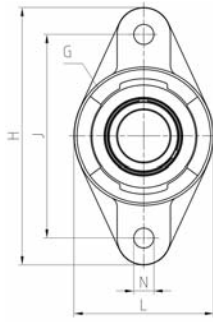

UCFLZ200

Wellendurchmesser
Einheit

Hauptabmessungen in mm

d [mm]		L	H	J	A	A1	A2	A4	H3 h8	e	N	s1	B
12	UCFLZ201	60,5	112,5	90,0	32,0	10,0	37,3	28,5	55	19	11,5	-	-
	USFLZ201	60,5	112,5	90,0	32,0	8,0	35,0	28,5	55	19	11,5	-	-
	ESFLZ201	60,5	112,5	90,0	32,0	8,0	41,1	28,5	55	19	11,5	-	-
	EXFLZ201	60,5	112,5	90,0	32,0	10,0	45,5	28,5	55	19	11,5	-	-
15	UCFLZ202	60,5	112,5	90,0	32,0	10,0	37,3	28,5	55	19	11,5	-	-
	USFLZ202	60,5	112,5	90,0	32,0	8,0	35,0	28,5	55	19	11,5	-	-
	ESFLZ202	60,5	112,5	90,0	32,0	8,0	41,1	28,5	55	19	11,5	-	-
	EXFLZ202	60,5	112,5	90,0	32,0	10,0	45,5	28,5	55	19	11,5	-	-
17	UCFLZ203	60,5	112,5	90,0	32,0	10,0	37,3	28,5	55	19	11,5	-	-
	USFLZ203	60,5	112,5	90,0	32,0	8,0	35,0	28,5	55	19	11,5	-	-
	ESFLZ203	60,5	112,5	90,0	32,0	8,0	41,1	28,5	55	19	11,5	-	-
	EXFLZ203	60,5	112,5	90,0	32,0	10,0	45,5	28,5	55	19	11,5	-	-
20	UCFLZ204	60,5	112,5	90,0	32,0	10,0	37,3	28,5	55	19	11,5	-	-
	USFLZ204	60,5	112,5	90,0	32,0	10,0	37,0	28,5	55	19	11,5	-	-
	ESFLZ204	60,5	112,5	90,0	32,0	10,0	42,4	28,5	55	19	11,5	-	-
	EXFLZ204	60,5	112,5	90,0	32,0	10,0	45,5	28,5	55	19	11,5	-	-
	UKFLZ205H	70,0	124,0	99,0	32,5	12,0	37,5	29,0	60	19	11,5	18,5	35,0
25	UCFLZ205	70,0	124,0	99,0	32,5	12,0	38,7	29,0	60	19	11,5	-	-
	USFLZ205	70,0	124,0	99,0	32,5	12,0	38,5	29,0	60	19	11,5	-	-
	ESFLZ205	70,0	124,0	99,0	32,5	12,0	42,4	29,0	60	19	11,5	-	-
	EXFLZ205	70,0	124,0	99,0	32,5	12,0	45,9	29,0	60	19	11,5	-	-
	UKFLZ206H	83,0	142,0	116,5	30,0	12,0	37,5	27,0	80	17	11,5	20,5	38,0
30	UCFLZ206	83,0	142,0	116,5	30,0	12,0	39,2	27,0	80	17	11,5	-	-
	USFLZ206	83,0	142,0	116,5	30,0	12,0	39,0	27,0	80	17	11,5	-	-
	ESFLZ206	83,0	142,0	116,5	30,0	12,0	43,7	27,0	80	17	11,5	-	-
	EXFLZ206	83,0	142,0	116,5	30,0	12,0	47,1	27,0	80	17	11,5	-	-
	UKFLZ207H	94,0	155,0	130,0	32,5	12,5	39,5	28,5	90	17	14,0	22,5	43,0
35	UCFLZ207	94,0	155,0	130,0	32,5	12,5	42,4	28,5	90	17	14,0	-	-
	USFLZ207	94,0	155,0	130,0	32,5	12,5	40,5	28,5	90	17	14,0	-	-
	ESFLZ207	94,0	155,0	130,0	32,5	12,5	46,4	28,5	90	17	14,0	-	-
	EXFLZ207	94,0	155,0	130,0	32,5	12,5	49,3	28,5	90	17	14,0	-	-
	UKFLZ208H	105,0	172,0	143,5	36,0	13,0	44,5	32,0	100	20	14,0	24,5	46,0
40	UCFLZ208	105,0	172,0	143,5	36,0	13,0	50,2	32,0	100	20	14,0	-	-
	USFLZ208	105,0	172,0	143,5	36,0	13,0	45,0	32,0	100	20	14,0	-	-
	ESFLZ208	105,0	172,0	143,5	36,0	13,0	52,7	32,0	100	20	14,0	-	-
	EXFLZ208	105,0	172,0	143,5	36,0	13,0	54,9	32,0	100	20	14,0	-	-
	UKFLZ209H	111,0	180,0	148,5	36,5	13,0	46,0	32,5	105	20	14,0	26,0	50,0

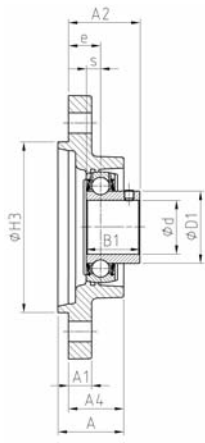

USFLZ200

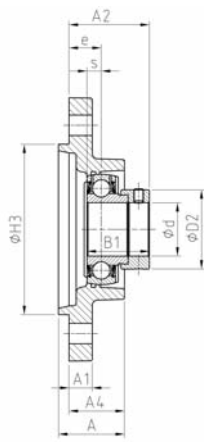

ESFLZ200

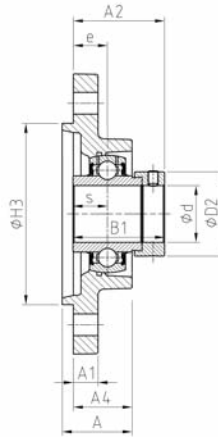

EXFLZ200

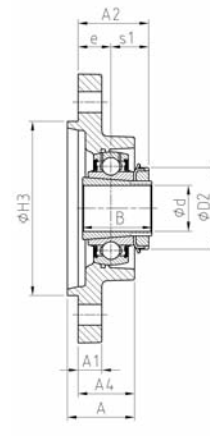

UKFLZ200H

Gehäuse

Einsatz

Tragzahl dyn.

Tragzahl stat.

Gewicht

Wellendurchmesser

B1	s	D1	D2	G			C _r [kN]	C _{or} [kN]	[kg]	d [mm]
31,0	12,7	29,0	-	R1/8"	FLZ204	UC201	12,80	6,65	0,5	12
22,0	6,0	24,6	-	R1/8"	FLZ203	US201	9,55	4,78	0,4	
28,6	6,5	-	28,6	R1/8"	FLZ203	ES201	9,55	4,78	0,4	
43,5	17,0	-	33,3	R1/8"	FLZ204	EX201	12,80	6,65	0,6	
31,0	12,7	29,0	-	R1/8"	FLZ204	UC202	12,80	6,65	0,5	15
22,0	6,0	24,6	-	R1/8"	FLZ203	US202	9,55	4,78	0,4	
28,6	6,5	-	28,6	R1/8"	FLZ203	ES202	9,55	4,78	0,4	
43,5	17,0	-	33,3	R1/8"	FLZ204	EX202	12,80	6,65	0,6	
31,0	12,7	29,0	-	R1/8"	FLZ204	UC203	12,80	6,65	0,5	17
22,0	6,0	24,6	-	R1/8"	FLZ203	US203	9,55	4,78	0,4	
28,6	6,5	-	28,6	R1/8"	FLZ203	ES203	9,55	4,78	0,4	
43,5	17,0	-	33,3	R1/8"	FLZ204	EX203	12,80	6,65	0,6	
31,0	12,7	29,0	-	R1/8"	FLZ204	UC204	12,80	6,65	0,5	20
25,0	7,0	29,0	-	R1/8"	FLZ204	US204	12,80	6,65	0,4	
30,9	7,5	-	33,3	R1/8"	FLZ204	ES204	12,80	6,65	0,5	
43,5	17,0	-	33,3	R1/8"	FLZ204	EX204	12,80	6,65	0,5	
-	-	-	38,0	R1/8"	FLZ205	UK205 + H2305	14,00	7,88	0,7	
34,0	14,3	34,0	-	R1/8"	FLZ205	UC205	14,00	7,88	0,7	25
27,0	7,5	34,0	-	R1/8"	FLZ205	US205	14,00	7,88	0,6	
30,9	7,5	-	38,1	R1/8"	FLZ205	ES205	14,00	7,88	0,7	
44,3	17,4	-	38,1	R1/8"	FLZ205	EX205	14,00	7,88	0,7	
-	-	-	45,0	R1/8"	FLZ206	UK206 + H2306	19,50	11,20	1,0	
38,1	15,9	40,3	-	R1/8"	FLZ206	UC206	19,50	11,20	0,9	30
30,0	8,0	40,3	-	R1/8"	FLZ206	US206	19,50	11,20	0,9	
35,7	9,0	-	44,5	R1/8"	FLZ206	ES206	19,50	11,20	0,9	
48,3	18,2	-	44,5	R1/8"	FLZ206	EX206	19,50	11,20	1,0	
-	-	-	52,0	R1/8"	FLZ207	UK207 + H2307	25,70	15,20	1,2	
42,9	17,5	48,0	-	R1/8"	FLZ207	UC207	25,70	15,20	1,2	35
32,0	8,5	48,0	-	R1/8"	FLZ207	US207	25,70	15,20	1,1	
38,9	9,5	-	55,6	R1/8"	FLZ207	ES207	25,70	15,20	1,2	
51,1	18,8	-	55,6	R1/8"	FLZ207	EX207	25,70	15,20	1,3	
-	-	-	58,0	R1/8"	FLZ208	UK208 + H2308	29,60	18,20	1,7	
49,2	19,0	53,0	-	R1/8"	FLZ208	UC208	29,60	18,20	1,6	40
34,0	9,0	53,0	-	R1/8"	FLZ208	US208	29,60	18,20	1,6	
43,7	11,0	-	60,3	R1/8"	FLZ208	ES208	29,60	18,20	1,6	
56,3	21,4	-	60,3	R1/8"	FLZ208	EX208	29,60	18,20	1,8	
-	-	-	65,0	R1/8"	FLZ209	UK209 + H2309	31,85	20,80	1,9	



Gehäuse FLZ200 nachschmierbar

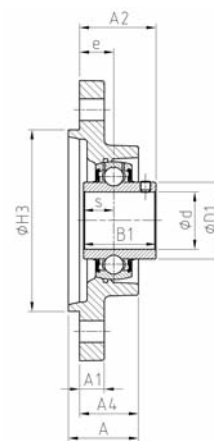
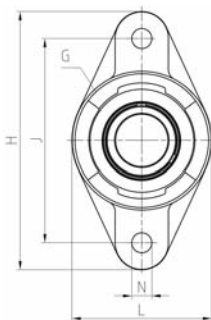

UCFLZ200

Wellendurchmesser
Einheit

Hauptabmessungen in mm

d [mm]		L	H	J	A	A1	A2	A4	H3 h8	e	N	s1	B
45	UCFLZ209	111,0	180,0	148,5	36,5	13,0	50,2	32,5	105	20	14,0	-	-
	USFLZ209	111,0	180,0	148,5	36,5	13,0	51,0	32,5	105	20	14,0	-	-
	ESFLZ209	111,0	180,0	148,5	36,5	13,0	52,7	32,5	105	20	14,0	-	-
	EXFLZ209	111,0	180,0	148,5	36,5	13,0	54,9	32,5	105	20	14,0	-	-
	UKFLZ210H	116,0	190,0	157,0	41,0	13,0	51,5	37,0	105	24	14,0	27,5	55,0
50	UCFLZ210	116,0	190,0	157,0	41,0	13,0	56,6	37,0	105	24	14,0	-	-
	USFLZ210	116,0	190,0	157,0	41,0	13,0	56,6	37,0	105	24	14,0	-	-
	ESFLZ210	116,0	190,0	157,0	41,0	13,0	56,7	37,0	105	24	14,0	-	-
	EXFLZ210	116,0	190,0	157,0	41,0	13,0	62,1	37,0	105	24	14,0	-	-
55	UKFLZ212H	138,0	238,0	202,0	49,0	16,0	61,0	45,0	130	30	18,0	31,0	62,0
60	UCFLZ212	138,0	238,0	202,0	49,0	16,0	69,7	45,0	130	30	18,0	-	-
	USFLZ212	138,0	238,0	202,0	49,0	16,0	68,8	45,0	130	30	18,0	-	-
	ESFLZ212	138,0	238,0	202,0	49,0	16,0	67,3	45,0	130	30	18,0	-	-
	EXFLZ212	138,0	238,0	202,0	49,0	16,0	76,8	45,0	130	30	18,0	-	-

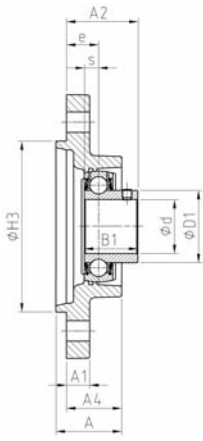

USFLZ200

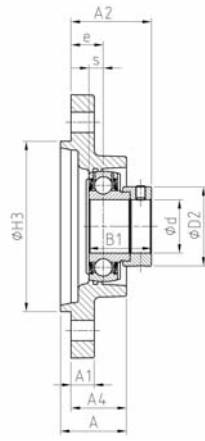

ESFLZ200

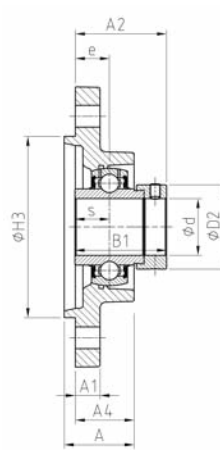

EXFLZ200

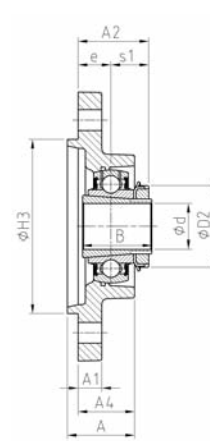

UKFLZ200H

					Gehäuse	Einsatz	Tragzahl dyn.	Tragzahl stat.	Gewicht	Wellendurchmesser
B1	s	D1	D2	G			C _r [kN]	C _{0r} [kN]	[kg]	d [mm]
49,2	19,0	57,2	-	R1/8"	FLZ209	UC209	31,85	20,80	1,8	45
41,2	10,2	57,2	-	R1/8"	FLZ209	US209	31,85	20,80	1,8	
43,7	11,0	-	63,5	R1/8"	FLZ209	ES209	31,85	20,80	1,8	
56,3	21,4	-	63,5	R1/8"	FLZ209	EX209	31,85	20,80	2,0	
-	-	-	70,0	R1/8"	FLZ210	UK210 + H2310	35,10	23,20	2,3	50
51,6	19,0	61,8	-	R1/8"	FLZ210	UC210	35,10	23,20	2,2	
43,5	10,9	61,8	-	R1/8"	FLZ210	US210	35,10	23,20	2,1	
43,7	11,0	-	69,9	R1/8"	FLZ210	ES210	35,10	23,20	2,2	
62,7	24,6	-	69,9	R1/8"	FLZ210	EX210	35,10	23,20	2,4	55
-	-	-	80,0	R1/8"	FLZ212	UK212 + H2312	52,50	32,80	3,5	
65,1	25,4	74,9	-	R1/8"	FLZ212	UC212	52,50	32,80	3,5	
53,7	14,9	74,9	-	R1/8"	FLZ212	US212	52,50	32,80	3,3	
49,3	12,0	-	84,2	R1/8"	FLZ212	ES212	52,50	32,80	3,2	60
77,7	30,9	-	84,2	R1/8"	FLZ212	EX212	52,50	32,80	3,9	

Gehäuse FD200 nachschmierbar

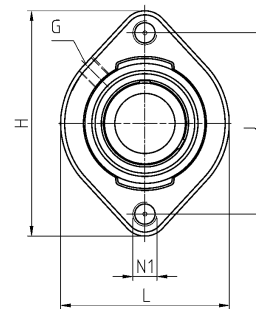
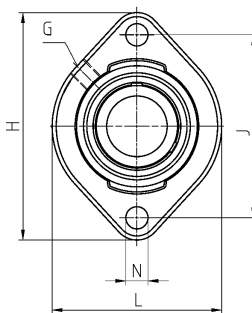
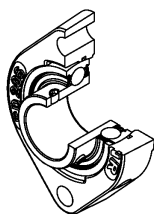

Wellendurchmesser
Einheit

Hauptabmessungen in mm

d [mm]		L	H	J	A	A2	e	N1	N	B1	s	D1
12	USFD201	58,7	81,0	63,5	15,0	24,4	8,4	M6	6,5	22,0	6,0	24,6
	ESFD201	58,7	81,0	63,5	15,0	30,5	8,4	M6	6,5	28,6	6,5	-
15	USFD202	58,7	81,0	63,5	15,0	24,4	8,4	M6	6,5	22,0	6,0	24,6
	ESFD202	58,7	81,0	63,5	15,0	30,5	8,4	M6	6,5	28,6	6,5	-
17	USFD203	58,7	81,0	63,5	15,0	24,4	8,4	M6	6,5	22,0	6,0	24,6
	ESFD203	58,7	81,0	63,5	15,0	30,5	8,4	M6	6,5	28,6	6,5	-
20	USFD204	66,5	90,5	71,4	17,0	27,5	9,5	M10	9,0	25,0	7,0	29,0
	ESFD204	66,5	90,5	71,4	17,0	32,9	9,5	M10	9,0	30,9	7,5	-
25	USFD205	71,0	97,0	76,2	17,5	29,4	9,9	M12	9,0	27,0	7,5	34,0
	ESFD205	71,0	97,0	76,2	17,5	33,3	9,9	M12	9,0	30,9	7,5	-
30	USFD206	84,0	112,5	90,5	20,5	33,4	11,4	M12	11,0	30,0	8,0	40,3
	ESFD206	84,0	112,5	90,5	20,5	38,1	11,4	M12	11,0	35,7	9,0	-
35	USFD207	94,0	126,0	100,0	22,0	35,9	12,4	M12	11,0	32,0	8,5	48,0
	ESFD207	94,0	126,0	100,0	22,0	41,8	12,4	M12	11,0	38,9	9,5	-
40	USFD208	104,0	148,0	119,0	24,0	37,1	12,05	M12	14,0	34,0	9,0	53,0
	ESFD208	104,0	148,0	119,0	24,0	44,8	12,05	M12	14,0	43,7	11,0	-

Bestellbezeichnung für die Ausführung mit Befestigungsgewinde: z. B.: USFD204M10

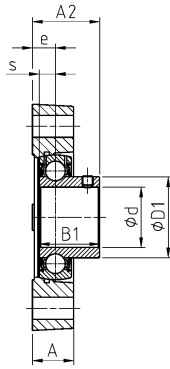

USFD200

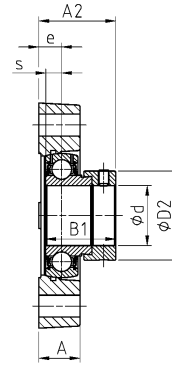

ESFD200

D2	G	Gehäuse	Einsatz	Tragzahl dyn.	Tragzahl stat.	Gewicht	Wellendurch- messer
-	M6x1	FD203	US201	9,55	4,78	0,3	12
28,6	M6x1	FD203	ES201	9,55	4,78	0,3	12
-	M6x1	FD203	US202	9,55	4,78	0,3	15
28,6	M6x1	FD203	ES202	9,55	4,78	0,3	15
-	M6x1	FD203	US203	9,55	4,78	0,3	17
28,6	M6x1	FD203	ES203	9,55	4,78	0,3	17
-	M6x1	FD204	US204	12,80	6,65	0,4	20
33,3	M6x1	FD204	ES204	12,80	6,65	0,4	20
-	M6x1	FD205	US205	14,00	7,88	0,5	25
38,1	M6x1	FD205	ES205	14,00	7,88	0,5	25
-	R1/8"	FD206	US206	19,50	11,20	0,7	30
44,5	R1/8"	FD206	ES206	19,50	11,20	0,7	30
-	R1/8"	FD207	US207	25,70	15,20	1,0	35
55,6	R1/8"	FD207	ES207	25,70	15,20	1,0	35
-	R1/8"	FD208	US208	29,60	18,20	1,3	40
60,3	R1/8"	FD208	ES208	29,60	18,20	1,3	40

Gehäuse FAE200 nachschmierbar

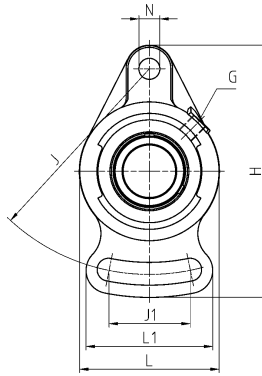
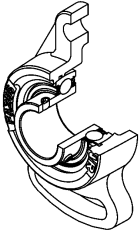

Wellendurchmesser		Einheit		Hauptabmessungen in mm								
d [mm]		L	H	J	J1	A	A1	A2	L1	w +0,2	H3 +0,2	e
20	USFAE204	61	112	90	30,0	20,0	10,0	28,5	52	2,0	50,8	10,5
	ESFAE204	61	112	90	30,0	20,0	10,0	33,9	52	2,0	50,8	10,5
25	USFAE205	70	124	99	37,5	22,5	11,0	32,0	63	3,5	63,5	12,5
	ESFAE205	70	124	99	37,5	22,5	11,0	35,9	63	3,5	63,5	12,5
30	USFAE206	80	142	117	40,0	24,0	12,0	35,0	65	3,0	73,0	13,0
	ESFAE206	80	142	117	40,0	24,0	12,0	39,7	65	3,0	73,0	13,0
35	USFAE207	90	155	128	45,0	26,5	12,5	38,5	75	4,5	82,5	15,0
	ESFAE207	90	155	128	45,0	26,5	12,5	44,4	75	4,5	82,5	15,0

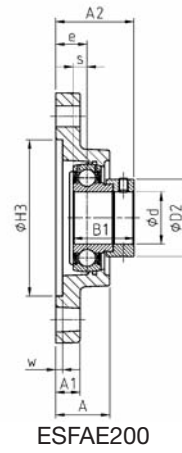
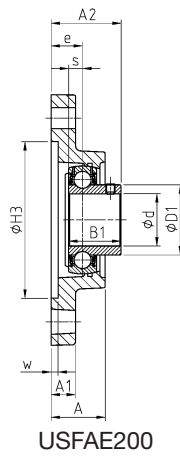

N	B1	s	D1	D2	G	Gehäuse	Einsatz	C _r [kN]	C _{or} [kN]	Gewicht [kg]	Wellendurchmesser [mm]
11,5	25,0	7,0	29,0	-	R1/8"	FAE204	US204	12,80	6,65	0,4	20
11,5	30,9	7,5	-	33,3	R1/8"	FAE204	ES204	12,80	6,65	0,5	
11,5	27,0	7,5	34,0	-	R1/8"	FAE205	US205	14,00	7,88	0,5	25
11,5	30,9	7,5	-	38,1	R1/8"	FAE205	ES205	14,00	7,88	0,5	
11,5	30,0	8,0	40,3	-	R1/8"	FAE206	US206	19,50	11,20	0,8	30
11,5	35,7	9,0	-	44,5	R1/8"	FAE206	ES206	19,50	11,20	0,8	
14,0	32,0	8,5	48,0	-	R1/8"	FAE207	US207	25,70	15,20	1,1	35
14,0	38,9	9,5	-	55,6	R1/8"	FAE207	ES207	25,70	15,20	1,2	

Gehäuse FA200 nachschmierbar

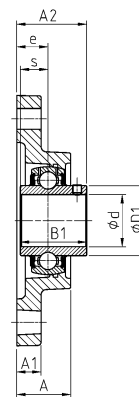
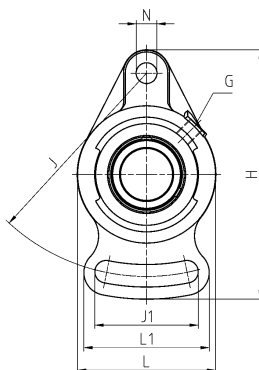

UCFA200

Wellendurchmesser		Einheit		Hauptabmessungen in mm												
d [mm]		L	H	J	J1	A	A1	A2	L1	e	N	s1	B	B1	s	
12	UCFA201	60	102	78	40	25,5	12	33,3	54	15	10	-	-	31,0	12,7	
	USFA201	57	95	75	37	22,0	9	29,0	47	13	10	-	-	22,0	6,0	
	ESFA201	57	95	75	37	22,0	9	35,1	47	13	10	-	-	28,6	6,5	
	EXFA201	60	102	78	40	25,5	12	41,5	54	15	10	-	-	43,5	17,0	
15	UCFA202	60	102	78	40	25,5	12	33,3	54	15	10	-	-	31,0	12,7	
	USFA202	57	95	75	37	22,0	9	29,0	47	13	10	-	-	22,0	6,0	
	ESFA202	57	95	75	37	22,0	9	35,1	47	13	10	-	-	28,6	6,5	
	EXFA202	60	102	78	40	25,5	12	41,5	54	15	10	-	-	43,5	17,0	
17	UCFA203	60	102	78	40	25,5	12	33,3	54	15	10	-	-	31,0	12,7	
	USFA203	57	95	75	37	22,0	9	29,0	47	13	10	-	-	22,0	6,0	
	ESFA203	57	95	75	37	22,0	9	35,1	47	13	10	-	-	28,6	6,5	
	EXFA203	60	102	78	40	25,5	12	41,5	54	15	10	-	-	43,5	17,0	
20	UCFA204	60	102	78	40	25,5	12	33,3	54	15	10	-	-	31,0	12,7	
	USFA204	60	102	78	40	25,5	12	33,0	54	15	10	-	-	25,0	7,0	
	ESFA204	60	102	78	40	25,5	12	38,4	54	15	10	-	-	30,9	7,5	
	EXFA204	60	102	78	40	25,5	12	41,5	54	15	10	-	-	43,5	17,0	
	UKFA205H	68	125	98	51	27,0	14	34,5	65	16	12	18,5	35,0	-	-	
25	UCFA205	68	125	98	51	27,0	14	35,7	65	16	12	-	-	34,0	14,3	
	USFA205	68	125	98	51	27,0	14	35,5	65	16	12	-	-	27,0	7,5	
	ESFA205	68	125	98	51	27,0	14	39,4	65	16	12	-	-	30,9	7,5	
	EXFA205	68	125	98	51	27,0	14	42,9	65	16	12	-	-	44,3	17,4	
	UKFA206H	80	144	117	58	31,0	14	38,5	72	18	12	20,5	38,0	-	-	
30	UCFA206	80	144	117	58	31,0	14	40,2	72	18	12	-	-	38,1	15,9	
	USFA206	80	144	117	58	31,0	14	40,0	72	18	12	-	-	30,0	8,0	
	ESFA206	80	144	117	58	31,0	14	44,7	72	18	12	-	-	35,7	9,0	
	EXFA206	80	144	117	58	31,0	14	48,1	72	18	12	-	-	48,3	18,2	
	UKFA207H	90	161	130	66	34,0	16	41,5	82	19	15	22,5	43,0	-	-	
35	UCFA207	90	161	130	66	34,0	16	44,4	82	19	15	-	-	42,9	17,5	
	USFA207	90	161	130	66	34,0	16	42,5	82	19	15	-	-	32,0	8,5	
	ESFA207	90	161	130	66	34,0	16	48,4	82	19	15	-	-	38,9	9,5	
	EXFA207	90	161	130	66	34,0	16	51,3	82	19	15	-	-	51,1	18,8	
	UKFA208H	100	175	144	71	36,0	16	45,5	87	21	15	24,5	46,0	-	-	
40	UCFA208	100	175	144	71	36,0	16	51,2	87	21	15	-	-	49,2	19,0	
	USFA208	100	175	144	71	36,0	16	46,0	87	21	15	-	-	34,0	9,0	
	ESFA208	100	175	144	71	36,0	16	53,7	87	21	15	-	-	43,7	11,0	
	EXFA208	100	175	144	71	36,0	16	55,9	87	21	15	-	-	56,3	21,4	
	UKFA209H	108	181	148	72	38,0	18	48,0	90	22	15	26,0	50,0	-	-	

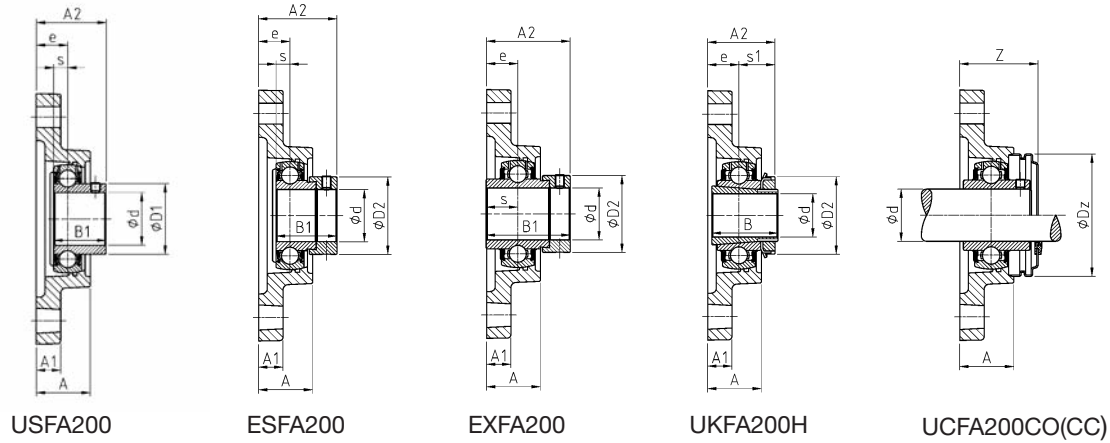

USFA200

ESFA200

EXFA200

UKFA200H

UCFA200CO(CC)

D1	D2	G	Z	Dz	Gehäuse	Einsatz	Schutzkappe offen *	Schutzkappe geschlossen **	Tragzahl dyn.	Tragzahl stat.	Gewicht	Wellendurch- messer
D1	D2	G	Z	Dz					C _r [kN]	C _{Or} [kN]	[kg]	d [mm]
29,0	-	M6x1	36,5	54,0	FA204	UC201	CO	CC	12,80	6,65	0,5	12
24,6	-	M6x1	33,0	46,0	FA203	US201	CO	CC	9,55	4,78	0,4	
-	28,6	M6x1	***	***	FA203	ES201	***	***	9,55	4,78	0,5	
-	33,3	M6x1	***	***	FA204	EX201	***	***	12,80	6,65	0,6	
29,0	-	M6x1	36,5	54,0	FA204	UC202	CO	CC	12,80	6,65	0,6	15
24,6	-	M6x1	33,0	46,0	FA203	US202	CO	CC	9,55	4,78	0,4	
-	28,6	M6x1	***	***	FA203	ES202	***	***	9,55	4,78	0,5	
-	33,3	M6x1	***	***	FA204	EX202	***	***	12,80	6,65	0,6	
29,0	-	M6x1	33,0	54,0	FA204	UC203	CO	CC	12,80	6,65	0,5	17
24,6	-	M6x1	33,0	46,0	FA203	US203	CO	CC	9,55	4,78	0,5	
-	28,6	M6x1	***	***	FA203	ES203	***	***	9,55	4,78	0,5	
-	33,3	M6x1	***	***	FA204	EX203	***	***	12,80	6,65	0,6	
29,0	-	M6x1	36,5	54,0	FA204	UC204	CO	CC	12,80	6,65	0,5	20
29,0	-	M6x1	36,5	54,0	FA204	US204	CO	CC	12,80	6,65	0,5	
-	33,3	M6x1	***	***	FA204	ES204	***	***	12,80	6,65	0,6	
-	33,3	M6x1	***	***	FA204	EX204	***	***	12,80	6,65	0,6	
-	38,0	M6x1	39,1	60,0	FA205	UK205 + H2305	CO	CC	14,00	7,88	0,7	
34,0	-	M6x1	39,1	60,0	FA205	UC205	CO	CC	14,00	7,88	0,7	25
34,0	-	M6x1	39,1	60,0	FA205	US205	CO	CC	14,00	7,88	0,7	
-	38,1	M6x1	***	***	FA205	ES205	***	***	14,00	7,88	0,7	
-	38,1	M6x1	***	***	FA205	EX205	***	***	14,00	7,88	0,8	
-	45,0	M6x1	44,1	70,0	FA206	UK206 + H2306	CO	CC	19,50	11,20	1,2	
40,3	-	M6x1	44,1	70,0	FA206	UC206	CO	CC	19,50	11,20	1,2	30
40,3	-	M6x1	44,1	70,0	FA206	US206	CO	CC	19,50	11,20	1,1	
-	44,5	M6x1	***	***	FA206	ES206	***	***	19,50	11,20	1,2	
-	44,5	M6x1	***	***	FA206	EX206	***	***	19,50	11,20	1,3	
-	52,0	M6x1	48,3	80,0	FA207	UK207 + H2307	CO	CC	25,70	15,20	1,6	
48,0	-	M6x1	48,3	80,0	FA207	UC207	CO	CC	25,70	15,20	1,6	35
48,0	-	M6x1	48,3	80,0	FA207	US207	CO	CC	25,70	15,20	1,5	
-	55,6	M6x1	***	***	FA207	ES207	***	***	25,70	15,20	1,6	
-	55,6	M6x1	***	***	FA207	EX207	***	***	25,70	15,20	1,7	
-	58,0	M6x1	55,1	88,0	FA208	UK208 + H2308	CO	CC	29,60	18,20	2,1	
53,0	-	M6x1	55,1	88,0	FA208	UC208	CO	CC	29,60	18,20	2,0	40
53,0	-	M6x1	55,1	88,0	FA208	US208	CO	CC	29,60	18,20	2,0	
-	60,3	M6x1	***	***	FA208	ES208	***	***	29,60	18,20	2,0	
-	60,3	M6x1	***	***	FA208	EX208	***	***	29,60	18,20	2,1	
-	65,0	M6x1	56,3	95,0	FA209	UK209 + H2309	CO	CC	31,85	20,80	2,4	

* = mit einer offenen Schutzkappe für durchgehende Wellen: Nachsetzzeichen CO wie Bestellbeispiel Seite 6

** = mit einer geschlossenen Schutzkappe für Wellenenden: Nachsetzzeichen CC wie Bestellbeispiel Seite 6

*** = mit Schutzkappen für Einsätze mit Excentring auf Anfrage lieferbar

Gehäuse FA200 nachschmierbar

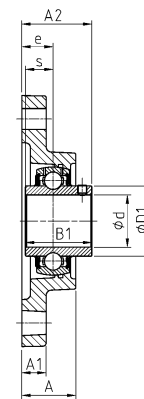
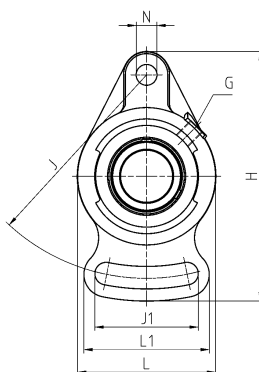

UCFA200

Wellendurchmesser		Einheit		Hauptabmessungen in mm											
d [mm]		L	H	J	J1	A	A1	A2	L1	e	N	s1	B	B1	s
45	UCFA209	108	181	148	72	38,0	18	52,2	90	22	15	-	-	49,2	19,0
	USFA209	108	181	148	72	38,0	18	53,0	90	22	15	-	-	41,2	10,2
	ESFA209	108	181	148	72	38,0	18	54,7	90	22	15	-	-	43,7	11,0
	EXFA209	108	181	148	72	38,0	18	56,9	90	22	15	-	-	56,3	21,4
	UKFA210H	115	190	157	76	40,0	18	49,5	94	22	15	27,5	55,0	-	-
50	UCFA210	115	190	157	76	40,0	18	54,6	94	22	15	-	-	51,6	19,0
	USFA210	115	190	157	76	40,0	18	54,6	94	22	15	-	-	43,5	10,9
	ESFA210	115	190	157	76	40,0	18	54,7	94	22	15	-	-	43,7	11,0
	EXFA210	115	190	157	76	40,0	18	60,1	94	22	15	-	-	62,7	24,6
	UKFA211H	130	219	184	86	43,0	20	54,0	104	25	16	29,0	59,0	-	-
55	UCFA211	130	219	184	86	43,0	20	58,4	104	25	16	-	-	55,6	22,2
	USFA211	130	219	184	86	43,0	20	58,5	104	25	16	-	-	45,3	11,8
	ESFA211	130	219	184	86	43,0	20	61,4	104	25	16	-	-	48,4	12,0
	EXFA211	130	219	184	86	43,0	20	68,6	104	25	16	-	-	71,3	27,7
	UKFA212H	140	250	202	92	48,0	20	60,0	118	29	23	31,0	62,0	-	-
60	UCFA212	140	250	202	92	48,0	20	68,7	118	29	23	-	-	65,1	25,4
	USFA212	140	250	202	92	48,0	20	67,8	118	29	23	-	-	53,7	14,9
	ESFA212	140	250	202	92	48,0	20	66,3	118	29	23	-	-	49,3	12,0
	EXFA212	140	250	202	92	48,0	20	75,8	118	29	23	-	-	77,7	30,9

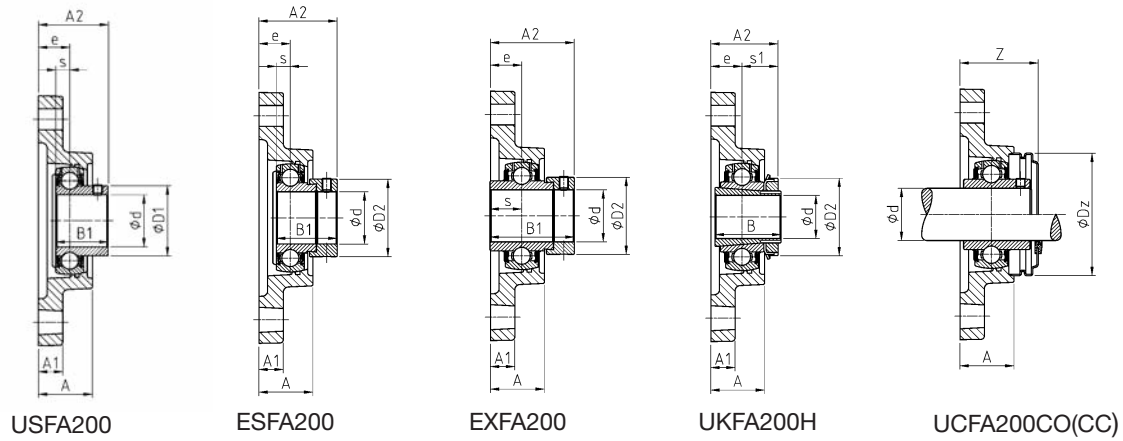

D1	D2	G	Z	Dz	Gehäuse	Einsatz	Schutzkappe offen *	Schutzkappe geschlossen **	Tragzahl dyn.	Tragzahl stat.	Gewicht	Wellendurch- messer
									C_r [kN]	C_{or} [kN]	[kg]	d [mm]
57,2	-	M6x1	56,3	95,0	FA209	UC209	CO	CC	31,85	20,80	2,3	45
57,2	-	M6x1	56,3	95,0	FA209	US209	CO	CC	31,85	20,80	2,3	45
-	63,5	M6x1	***	***	FA209	ES209	***	***	31,85	20,80	2,3	45
-	63,5	M6x1	***	***	FA209	EX209	***	***	31,85	20,80	2,5	45
-	70,0	M6x1	59,3	100,0	FA210	UK210 + H2310	CO	CC	35,10	23,20	2,9	45
61,8	-	M6x1	59,3	100,0	FA210	UC210	CO	CC	35,10	23,20	2,7	50
61,8	-	M6x1	59,3	100,0	FA210	US210	CO	CC	35,10	23,20	2,7	50
-	69,9	M6x1	***	***	FA210	ES210	***	***	35,10	23,20	2,7	50
-	69,9	M6x1	***	***	FA210	EX210	***	***	35,10	23,20	2,9	50
-	75,0	M6x1	62,8	110,0	FA211	UK211 + H2311	CO	CC	43,55	29,20	3,6	50
69,0	-	M6x1	62,8	110,0	FA211	UC211	CO	CC	43,55	29,20	3,5	55
69,0	-	M6x1	62,8	110,0	FA211	US211	CO	CC	43,55	29,20	3,5	55
-	76,2	M6x1	***	***	FA211	ES211	***	***	43,55	29,20	3,3	55
-	76,2	M6x1	***	***	FA211	EX211	***	***	43,55	29,20	3,8	55
-	80,0	M6x1	73,3	120,0	FA212	UK212 + H2312	CO	CC	52,50	32,80	4,2	60
74,9	-	M6x1	73,3	120,0	FA212	UC212	CO	CC	52,50	32,80	4,2	60
74,9	-	M6x1	73,3	120,0	FA212	US212	CO	CC	52,50	32,80	4,0	60
-	84,2	M6x1	***	***	FA212	ES212	***	***	52,50	32,80	3,9	60
-	84,2	M6x1	***	***	FA212	EX212	***	***	52,50	32,80	4,6	60

* = mit einer offenen Schutzkappe für durchgehende Wellen: Nachsetzzeichen CO wie Bestellbeispiel Seite 6

** = mit einer geschlossenen Schutzkappe für Wellenenden: Nachsetzzeichen CC wie Bestellbeispiel Seite 6

*** = mit Schutzkappen für Einsätze mit Excenterring auf Anfrage lieferbar

Gehäuse T200 nachschmierbar
T300 nachschmierbar

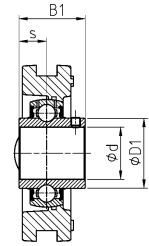
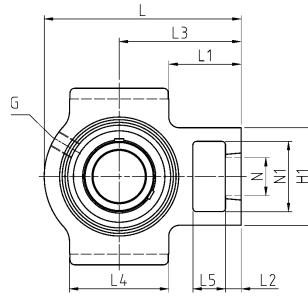
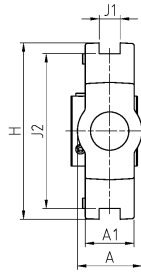
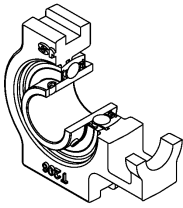

UCT200
UCT300

Wellendurchmesser		Einheit		Hauptabmessungen in mm													
d [mm]		L	H	J1	J2	A	A1	L1	L2	L3	L4	L5	H1	N	N1	s1	B
12	UCT201	94	89	12	76	32	21	35,5	10	61	51	16	51	19	32	-	-
	UST201	94	89	12	76	32	21	35,5	10	61	51	16	51	19	32	-	-
	EST201	94	89	12	76	32	21	35,5	10	61	51	16	51	19	32	-	-
	EXT201	94	89	12	76	32	21	35,5	10	61	51	16	51	19	32	-	-
15	UCT202	94	89	12	76	32	21	35,5	10	61	51	16	51	19	32	-	-
	UST202	94	89	12	76	32	21	35,5	10	61	51	16	51	19	32	-	-
	EST202	94	89	12	76	32	21	35,5	10	61	51	16	51	19	32	-	-
	EXT202	94	89	12	76	32	21	35,5	10	61	51	16	51	19	32	-	-
17	UCT203	94	89	12	76	32	21	35,5	10	61	51	16	51	19	32	-	-
	UST203	94	89	12	76	32	21	35,5	10	61	51	16	51	19	32	-	-
	EST203	94	89	12	76	32	21	35,5	10	61	51	16	51	19	32	-	-
	EXT203	94	89	12	76	32	21	35,5	10	61	51	16	51	19	32	-	-
20	UCT204	94	89	12	76	32	21	35,5	10	61	51	16	51	19	32	-	-
	UST204	94	89	12	76	32	21	35,5	10	61	51	16	51	19	32	-	-
	EST204	94	89	12	76	32	21	35,5	10	61	51	16	51	19	32	-	-
	EXT204	94	89	12	76	32	21	35,5	10	61	51	16	51	19	32	-	-
	UKT205H	97	89	12	76	32	24	36,5	10	62	51	16	51	19	32	18,5	35
	UKT305H	122	89	12	80	36	26	43,5	14	76	65	16	62	26	36	21,5	35
25	UCT205	97	89	12	76	32	24	36,5	10	62	51	16	51	19	32	-	-
	UST205	97	89	12	76	32	24	36,5	10	62	51	16	51	19	32	-	-
	EST205	97	89	12	76	32	24	36,5	10	62	51	16	51	19	32	-	-
	EXT205	97	89	12	76	32	24	36,5	10	62	51	16	51	19	32	-	-
	UKT206H	113	102	12	89	37	28	41,5	10	70	57	16	56	22	37	20,5	38
	UCT305	122	89	12	80	36	26	43,5	14	76	65	16	62	26	36	-	-
	EXT305	122	89	12	80	36	26	43,5	14	76	65	16	62	26	36	-	-
	UKT306H	137	100	16	90	41	28	48,0	16	85	74	18	70	28	41	23,0	38
30	UCT206	113	102	12	89	37	28	41,5	10	70	57	16	56	22	37	-	-
	UST206	113	102	12	89	37	28	41,5	10	70	57	16	56	22	37	-	-
	EST206	113	102	12	89	37	28	41,5	10	70	57	16	56	22	37	-	-
	EXT206	113	102	12	89	37	28	41,5	10	70	57	16	56	22	37	-	-
	UKT207H	129	102	12	89	37	30	46,0	13	78	64	16	64	22	37	22,5	43
	UCT306	137	100	16	90	41	28	48,0	16	85	74	18	70	28	41	-	-
	EXT306	137	100	16	90	41	28	48,0	16	85	74	18	70	28	41	-	-
	UKT307H	150	111	16	100	45	32	54,0	17	94	80	20	75	30	45	25,5	43

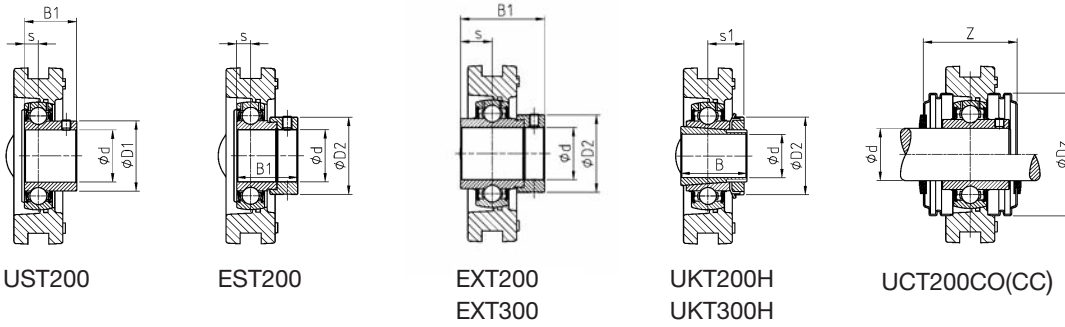

B1	s	D1	D2	G	Z	Dz	Gehäuse	Einsatz	Schutzkappe offen *	Schutzkappe geschlossen **	Tragzahl dyn.	Tragzahl stat.	Gewicht	Wellendurch- messer
											C _r [kN]	C _{0r} [kN]	[kg]	d [mm]
31,0	12,7	29,0	-	M6x1	43,7	54,0	T204	UC201	CO	CC	12,80	6,65	0,8	12
22,0	6,0	24,6	-	M6x1	43,7	46,0	T204	US201	CO	CC	9,55	4,78	0,7	
28,6	6,5	-	28,6	M6x1	***	***	T204	ES201	***	***	9,55	4,78	0,7	
43,5	17,0	-	33,3	M6x1	***	***	T204	EX201	***	***	12,80	6,65	0,9	
31,0	12,7	29,0	-	M6x1	43,7	54,0	T204	UC202	CO	CC	12,80	6,65	0,8	15
22,0	6,0	24,6	-	M6x1	43,7	46,0	T204	US202	CO	CC	9,55	4,78	0,6	
28,6	6,5	-	28,6	M6x1	***	***	T204	ES202	***	***	9,55	4,78	0,7	
43,5	17,0	-	33,3	M6x1	***	***	T204	EX202	***	***	12,80	6,65	0,8	
31,0	12,7	29,0	-	M6x1	43,7	54,0	T204	UC203	CO	CC	12,80	6,65	0,7	17
22,0	6,0	24,6	-	M6x1	43,7	46,0	T204	US203	CO	CC	9,55	4,78	0,7	
28,6	6,5	-	28,6	M6x1	***	***	T204	ES203	***	***	9,55	4,78	0,7	
43,5	17,0	-	33,3	M6x1	***	***	T204	EX203	***	***	12,80	6,65	0,8	
31,0	12,7	29,0	-	M6x1	43,7	54,0	T204	UC204	CO	CC	12,80	6,65	0,7	20
25,0	7,0	29,0	-	M6x1	43,7	54,0	T204	US204	CO	CC	12,80	6,65	0,7	
30,9	7,5	-	33,3	M6x1	***	***	T204	ES204	***	***	12,80	6,65	0,7	
43,5	17,0	-	33,3	M6x1	***	***	T204	EX204	***	***	12,80	6,65	0,8	
-	-	-	38,0	M6x1	47,5	60,0	T205	UK205 + H2305	CO	CC	14,00	7,88	0,8	25
-	-	-	38,0	M6x1	-	-	T305	UK305 + H2305	-	-	22,36	11,50	1,4	
34,0	14,3	34,0	-	M6x1	47,5	60,0	T205	UC205	CO	CC	14,00	7,88	0,8	
27,0	7,5	34,0	-	M6x1	47,5	60,0	T205	US205	CO	CC	14,00	7,88	0,8	
30,9	7,5	-	38,1	M6x1	***	***	T205	ES205	***	***	14,00	7,88	0,8	30
44,3	17,4	-	38,1	M6x1	***	***	T205	EX205	***	***	14,00	7,88	0,9	
-	-	-	45,0	M6x1	52,5	70,0	T206	UK206 + H2306	CO	CC	19,50	11,20	1,3	
38,0	15,0	35,4	-	M6x1	-	-	T305	UC305	-	-	22,36	11,50	1,3	
46,8	16,7	-	42,8	M6x1	-	-	T305	EX305	-	-	22,36	11,50	1,3	30
-	-	-	45,0	M6x1	-	-	T306	UK306 + H2306	-	-	27,00	15,20	1,8	
38,1	15,9	40,3	-	M6x1	52,5	70,0	T206	UC206	CO	CC	19,50	11,20	1,2	
30,0	8,0	40,3	-	M6x1	52,5	70,0	T206	US206	CO	CC	19,50	11,20	1,2	
35,7	9,0	-	44,5	M6x1	***	***	T206	ES206	***	***	19,50	11,20	1,2	30
48,3	18,2	-	44,5	M6x1	***	***	T206	EX206	***	***	19,50	11,20	1,3	
-	-	-	52,0	M6x1	59,1	80,0	T207	UK207 + H2307	CO	CC	25,70	15,20	1,6	
43,0	17,0	44,6	-	M6x1	-	-	T306	UC306	-	-	27,00	15,20	1,8	
50,0	17,5	-	50,0	M6x1	-	-	T306	EX306	-	-	27,00	15,20	1,9	30
-	-	-	52,0	M6x1	-	-	T307	UK307 + H2307	-	-	33,50	19,20	2,5	

* = mit zwei offenen Schutzkappen für durchgehende Wellen: Nachsetzzeichen CO wie Bestellbeispiel Seite 6

** = mit einer offenen und einer geschlossenen Schutzkappe für Wellenenden: Nachsetzzeichen CC wie Bestellbeispiel Seite 6

*** = mit Schutzkappen für Einsätze mit Excentering auf Anfrage lieferbar



Gehäuse T200 nachschmierbar
T300 nachschmierbar

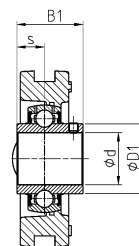
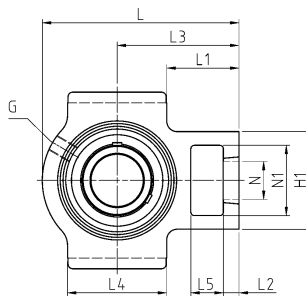
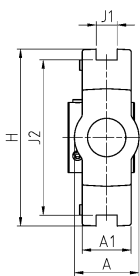
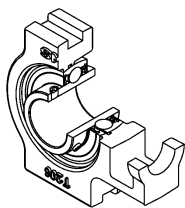

UCT200
UCT300

Wellendurchmesser		Einheit		Hauptabmessungen in mm													
d [mm]		L	H	J1	J2	A	A1	L1	L2	L3	L4	L5	H1	N	N1	s1	B
35	UCT207	129	102	12	89	37	30	46,0	13	78	64	16	64	22	37	-	-
	UST207	129	102	12	89	37	30	46,0	13	78	64	16	64	22	37	-	-
	EST207	129	102	12	89	37	30	46,0	13	78	64	16	64	22	37	-	-
	EXT207	129	102	12	89	37	30	46,0	13	78	64	16	64	22	37	-	-
	UKT208H	144	114	16	102	49	33	46,5	16	88	83	19	83	29	49	24,5	46
	UCT307	150	111	16	100	45	32	54,0	17	94	80	20	75	30	45	-	-
	EXT307	150	111	16	100	45	32	54,0	17	94	80	20	75	30	45	-	-
	UKT308H	162	124	18	112	50	34	55,5	19	100	89	22	83	32	50	27,5	46
40	UCT208	144	114	16	102	49	33	46,5	16	88	83	19	83	29	49	-	-
	UST208	144	114	16	102	49	33	46,5	16	88	83	19	83	29	49	-	-
	EST208	144	114	16	102	49	33	46,5	16	88	83	19	83	29	49	-	-
	EXT208	144	114	16	102	49	33	46,5	16	88	83	19	83	29	49	-	-
	UKT209H	144	117	16	102	49	35	45,5	16	87	83	19	83	29	49	26,0	50
	UCT308	162	124	18	112	50	34	55,5	19	100	89	22	83	32	50	-	-
	EXT308	162	124	18	112	50	34	55,5	19	100	89	22	83	32	50	-	-
	UKT309H	178	138	18	125	55	38	61,5	20	110	97	24	90	34	55	30,0	50
45	UCT209	144	117	16	102	49	35	45,5	16	87	83	19	83	29	49	-	-
	UST209	144	117	16	102	49	35	45,5	16	87	83	19	83	29	49	-	-
	EST209	144	117	16	102	49	35	45,5	16	87	83	19	83	29	49	-	-
	EXT209	144	117	16	102	49	35	45,5	16	87	83	19	83	29	49	-	-
	UKT210H	149	117	16	102	49	37	47,0	16	90	86	19	83	29	49	27,5	55
	UCT309	178	138	18	125	55	38	61,5	20	110	97	24	90	34	55	-	-
	EXT309	178	138	18	125	55	38	61,5	20	110	97	24	90	34	55	-	-
	UKT310H	192	151	20	140	61	40	65,0	22	118	106	27	98	37	61	32,0	55
50	UCT210	149	117	16	102	49	37	47,0	16	90	86	19	83	29	49	-	-
	UST210	149	117	16	102	49	37	47,0	16	90	86	19	83	29	49	-	-
	EST210	149	117	16	102	49	37	47,0	16	90	86	19	83	29	49	-	-
	EXT210	149	117	16	102	49	37	47,0	16	90	86	19	83	29	49	-	-
	UKT211H	171	146	22	130	64	38	58,5	19	106	95	25	102	35	64	29,0	59
	UCT310	192	151	20	140	61	40	65,0	22	118	106	27	98	37	61	-	-
	EXT310	192	151	20	140	61	40	65,0	22	118	106	27	98	37	61	-	-
	UKT311H	207	163	22	150	66	44	69,5	23	127	115	29	105	39	66	34,0	59

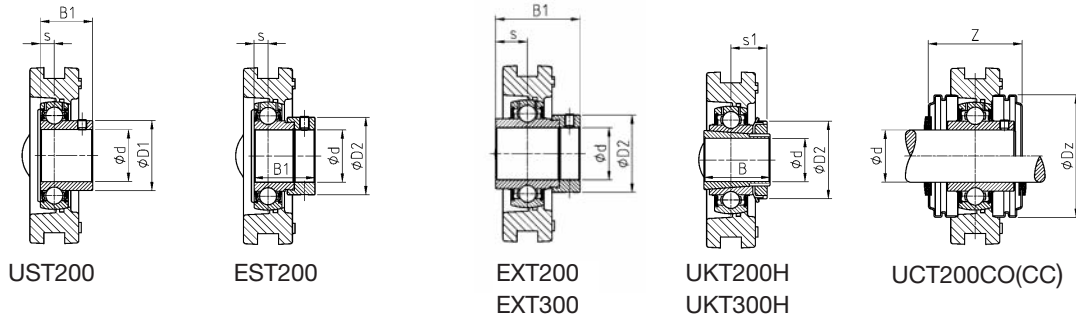

B1	s	D1	D2	G	Z	Dz	Gehäuse	Einsatz	Schutzkappe offen *	Schutzkappe geschlossen **	Tragzahl dyn.	Tragzahl stat.	Gewicht	Wellendurch- messer
											C_r [kN]	C_{or} [kN]	[kg]	d [mm]
42,9	17,5	48,0	-	M6x1	59,1	80,0	T207	UC207	CO	CC	25,70	15,20	1,6	35
32,0	8,5	48,0	-	M6x1	59,1	80,0	T207	US207	CO	CC	25,70	15,20	1,5	
38,9	9,5	-	55,6	M6x1	***	***	T207	ES207	***	***	25,70	15,20	1,6	
51,1	18,8	-	55,6	M6x1	***	***	T207	EX207	***	***	25,70	15,20	1,7	
-	-	-	58,0	M6x1	68,6	88,0	T208	UK208 + H2308	CO	CC	29,60	18,20	2,4	
48,0	19,0	48,9	-	M6x1	-	-	T307	UC307	-	-	33,50	19,20	2,3	
51,6	18,3	-	55,0	M6x1	-	-	T307	EX307	-	-	33,50	19,20	2,4	
-	-	-	58,0	M6x1	-	-	T308	UK308 + H2308	-	-	40,56	24,00	3,0	
49,2	19,0	53,0	-	M6x1	68,6	88,0	T208	UC208	CO	CC	29,60	18,20	2,3	40
34,0	9,0	53,0	-	M6x1	68,6	88,0	T208	US208	CO	CC	29,60	18,20	2,3	
43,7	11,0	-	60,3	M6x1	***	***	T208	ES208	***	***	29,60	18,20	2,3	
56,3	21,4	-	60,3	M6x1	***	***	T208	EX208	***	***	29,60	18,20	2,5	
-	-	-	65,0	M6x1	68,6	95,0	T209	UK209 + H2309	CO	CC	31,85	20,80	2,5	
52,0	19,0	56,5	-	M6x1	-	-	T308	UC308	-	-	40,56	24,00	3,0	
57,1	19,8	-	63,5	M6x1	-	-	T308	EX308	-	-	40,56	24,00	3,1	
-	-	-	65,0	M6x1	-	-	T309	UK309 + H2309	-	-	53,00	31,80	4,2	
49,2	19,0	57,2	-	M6x1	68,6	95,0	T209	UC209	CO	CC	31,85	20,80	2,3	45
41,2	10,2	57,2	-	M6x1	68,6	95,0	T209	US209	CO	CC	31,85	20,80	2,3	
43,7	11,0	-	63,5	M6x1	***	***	T209	ES209	***	***	31,85	20,80	2,4	
56,3	21,4	-	63,5	M6x1	***	***	T209	EX209	***	***	31,85	20,80	2,5	
-	-	-	70,0	M6x1	74,1	100,0	T210	UK210 + H2310	CO	CC	35,10	23,20	2,7	
57,0	22,0	61,8	-	M6x1	-	-	T309	UC309	-	-	53,00	31,80	4,0	
58,7	19,8	-	70,0	M6x1	-	-	T309	EX309	-	-	53,00	31,80	4,2	
-	-	-	70,0	M6x1	-	-	T310	UK310 + H2310	-	-	62,00	37,80	4,1	
51,6	19,0	61,8	-	M6x1	74,1	100,0	T210	UC210	CO	CC	35,10	23,20	2,5	50
43,5	10,9	61,8	-	M6x1	74,1	100,0	T210	US210	CO	CC	35,10	23,20	2,5	
43,7	11,0	-	69,9	M6x1	***	***	T210	ES210	***	***	35,10	23,20	2,5	
62,7	24,6	-	69,9	M6x1	***	***	T210	EX210	***	***	35,10	23,20	2,7	
-	-	-	75,0	M6x1	75,6	110,0	T211	UK211 + H2311	CO	CC	43,55	29,20	4,0	
61,0	22,0	68,7	-	M6x1	-	-	T310	UC310	-	-	62,00	37,80	4,0	
66,6	24,6	-	76,2	M6x1	-	-	T310	EX310	-	-	62,00	37,80	4,2	
-	-	-	75,0	M6x1	-	-	T311	UK311 + H2311	-	-	71,50	44,80	6,4	

* = mit zwei offenen Schutzkappen für durchgehende Wellen: Nachsetzzeichen CO wie Bestellbeispiel Seite 6

** = mit einer offenen und einer geschlossenen Schutzkappe für Wellenenden: Nachsetzzeichen CC wie Bestellbeispiel Seite 6

*** = mit Schutzkappen für Einsätze mit Excentring auf Anfrage lieferbar

Gehäuse T200 nachschmierbar
T300 nachschmierbar

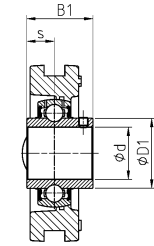
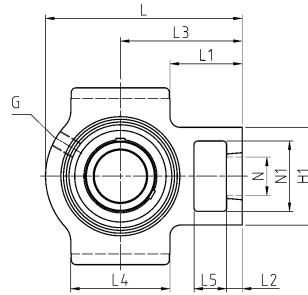
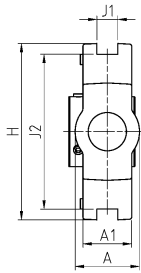
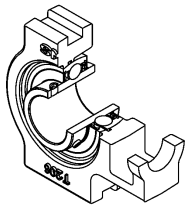

UCT200
UCT300

Wellendurchmesser		Einheit		Hauptabmessungen in mm													
d [mm]		L	H	J1	J2	A	A1	L1	L2	L3	L4	L5	H1	N	N1	s1	B
55	UCT211	171	146	22	130	64	38	58,5	19	106	95	25	102	35	64	-	-
	UST211	171	146	22	130	64	38	58,5	19	106	95	25	102	35	64	-	-
	EST211	171	146	22	130	64	38	58,5	19	106	95	25	102	35	64	-	-
	EXT211	171	146	22	130	64	38	58,5	19	106	95	25	102	35	64	-	-
	UKT212H	194	146	22	130	64	42	68,0	19	119	102	32	102	35	64	31,0	62
	UCT311	207	163	22	150	66	44	69,5	23	127	115	29	105	39	66	-	-
	EXT311	207	163	22	150	66	44	69,5	23	127	115	29	105	39	66	-	-
	UKT312H	220	178	22	160	71	46	73,5	25	135	123	31	113	41	71	36,5	62
60	UCT212	194	146	22	130	64	42	68,0	19	119	102	32	102	35	64	-	-
	UST212	194	146	22	130	64	42	68,0	19	119	102	32	102	35	64	-	-
	EST212	194	146	22	130	64	42	68,0	19	119	102	32	102	35	64	-	-
	EXT212	194	146	22	130	64	42	68,0	19	119	102	32	102	35	64	-	-
	UKT213H	224	167	26	151	70	44	76,5	21	137	121	32	111	41	70	32,0	65
	UCT312	220	178	22	160	71	46	73,5	25	135	123	31	113	41	71	-	-
	EXT312	220	178	22	160	71	46	73,5	25	135	123	31	113	41	71	-	-
	UKT313H	238	190	26	170	80	50	79,0	27	146	134	32	116	43	70	38,5	65
65	UCT213	224	167	26	151	70	44	76,5	21	137	121	32	111	41	70	-	-
	EXT213	224	167	26	151	70	44	76,5	21	137	121	32	111	41	70	-	-
	UKT215H	232	167	26	151	70	48	79,5	21	140	121	32	111	41	70	35,5	73
	UCT313	238	190	26	170	80	50	79,0	27	146	134	32	116	43	70	-	-
	EXT313	238	190	26	170	80	50	79,0	27	146	134	32	116	43	70	-	-
	UKT315H	262	216	26	192	90	55	85,0	27	160	150	36	132	46	85	42,5	73
70	UCT214	224	167	26	151	70	46	76,5	21	137	121	32	111	41	70	-	-
	EXT214	224	167	26	151	70	46	76,5	21	137	121	32	111	41	70	-	-
	UKT216H	235	184	26	165	70	51	79,5	21	140	121	32	111	41	70	39,0	78
	UCT314	252	202	26	180	90	52	85,0	27	155	140	36	130	46	85	-	-
	EXT314	252	202	26	180	90	52	85,0	27	155	140	36	130	46	85	-	-
	UKT316H	282	230	30	204	102	60	94,0	30	174	160	42	150	53	98	44,5	78
75	UCT215	232	167	26	151	70	48	79,5	21	140	121	32	111	41	70	-	-
	EXT215	232	167	26	151	70	48	79,5	21	140	121	32	111	41	70	-	-
	UKT217H	260	198	30	173	73	54	83,5	29	162	157	38	124	48	73	40,0	82
	UCT315	262	216	26	192	90	55	85,0	27	160	150	36	132	46	85	-	-
	EXT315	262	216	26	192	90	55	85,0	27	160	150	36	132	46	85	-	-
	UKT317H	298	240	32	214	102	64	98,0	32	183	170	42	152	53	98	48,0	82

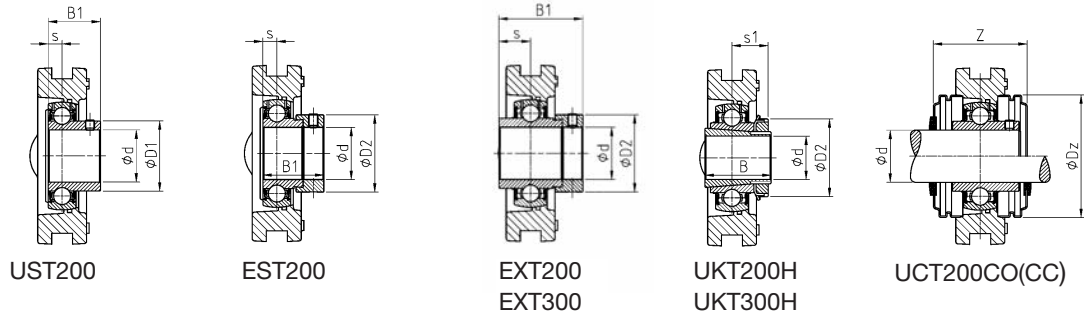

B1	s	D1	D2	G	Z	Dz	Gehäuse	Einsatz	Schutzkappe offen *	Schutzkappe geschlossen **	Tragzahl dyn.	Tragzahl stat.	Gewicht	Wellendurch- messer	
											C _r [kN]	C _{Or} [kN]	[kg]	d [mm]	
55,6	22,2	69,0	-	M6x1	75,6	110,0	T211	UC211	CO	CC	43,55	29,20	3,9	55	
45,3	11,8	69,0	-	M6x1	75,6	110,0	T211	US211	CO	CC	43,55	29,20	3,8		
48,4	12,0	-	76,2	M6x1	***	***	T211	ES211	***	***	43,55	29,20	3,6		
71,3	27,7	-	76,2	M6x1	***	***	T211	EX211	***	***	43,55	29,20	4,2		
-	-	-	80,0	M6x1	88,6	120,0	T212	UK212 + H2312	CO	CC	52,50	32,80	4,7		
66,0	25,0	74,9	-	M6x1	-	-	T311	UC311	-	-	71,50	44,80	6,1		
73,0	27,8	-	83,0	M6x1	-	-	T311	EX311	-	-	71,50	44,80	6,5		
-	-	-	80,0	M6x1	-	-	T312	UK312 + H2312	-	-	81,60	51,80	7,5		
65,1	25,4	74,9	-	M6x1	88,6	120,0	T212	UC212	CO	CC	52,50	32,80	4,7		60
53,7	14,9	74,9	-	M6x1	88,6	120,0	T212	US212	CO	CC	52,50	32,80	4,5		
49,3	12,0	-	84,2	M6x1	***	***	T212	ES212	***	***	52,50	32,80	4,4		
77,7	30,9	-	84,2	M6x1	***	***	T212	EX212	***	***	52,50	32,80	5,1		
-	-	-	85,0	M6x1	88,6	132,0	T213	UK213 + H2313	CO	CC	57,20	40,00	6,8		
71,0	26,0	81,0	-	M6x1	-	-	T312	UC312	-	-	81,60	51,80	7,6		
79,4	31,0	-	89,0	M6x1	-	-	T312	EX312	-	-	81,60	51,80	7,9		
-	-	-	85,0	M6x1	-	-	T313	UK313 + H2313	-	-	93,86	60,50	9,5		
65,1	25,4	82,0	-	M6x1	88,6	132,0	T213	UC213	CO	CC	57,20	40,00	6,8	65	
85,7	34,1	-	86,0	M6x1	***	***	T213	EX213	***	***	57,20	40,00	7,3		
-	-	-	98,0	M10x1	-	-	T215	UK215 + H2315	-	-	66,00	49,50	7,6		
75,0	30,0	87,5	-	M6x1	-	-	T313	UC313	-	-	93,86	60,50	9,5		
85,7	32,5	-	97,0	M6x1	-	-	T313	EX313	-	-	93,86	60,50	9,9		
-	-	-	98,0	M10x1	-	-	T315	UK315 + H2315	-	-	113,36	76,80	13,2		
74,6	30,2	86,5	-	M10x1	-	-	T214	UC214	-	-	62,00	45,00	6,9		70
85,7	34,1	-	96,8	M10x1	-	-	T214	EX214	-	-	62,00	45,00	7,4		
-	-	-	105,0	M10x1	-	-	T216	UK216 + H2316	-	-	72,50	54,20	8,7		
78,0	33,0	94,0	-	M10x1	-	-	T314	UC314	-	-	104,26	68,00	11,1		
92,1	34,2	-	102,0	M10x1	-	-	T314	EX314	-	-	104,26	68,00	11,7		
-	-	-	105,0	M10x1	-	-	T316	UK316 + H2316	-	-	122,85	86,50	16,2		
77,8	33,3	91,5	-	M10x1	-	-	T215	UC215	-	-	66,00	49,50	7,2	75	
92,1	37,3	-	102,0	M10x1	-	-	T215	EX215	-	-	66,00	49,50	7,9		
-	-	-	110,0	M10x1	-	-	T217	UK217 + H2317	-	-	83,20	63,80	11,2		
82,0	32,0	100,5	-	M10x1	-	-	T315	UC315	-	-	113,36	76,80	12,5		
100,0	37,3	-	113,0	M10x1	-	-	T315	EX315	-	-	113,36	76,80	13,5		
-	-	-	110,0	M10x1	-	-	T317	UK317 + H2317	-	-	132,60	96,50	19,0		

* = mit zwei offenen Schutzkappen für durchgehende Wellen: Nachsetzzeichen CO wie Bestellbeispiel Seite 6

** = mit einer offenen und einer geschlossenen Schutzkappe für Wellenenden: Nachsetzzeichen CC wie Bestellbeispiel Seite 6

*** = mit Schutzkappen für Einsätze mit Excenterring auf Anfrage lieferbar

Gehäuse T200 nachschmierbar
T300 nachschmierbar

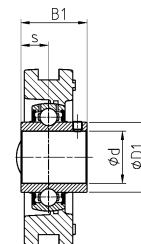
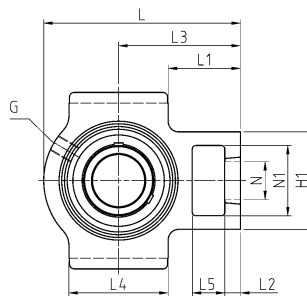
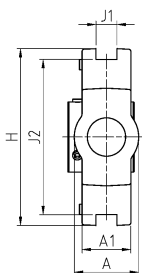
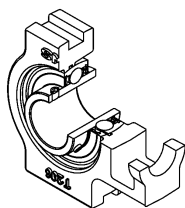

UCT200
UCT300

Wellendurchmesser		Einheit		Hauptabmessungen in mm													
d [mm]		L	H	J1	J2	A	A1	L1	L2	L3	L4	L5	H1	N	N1	s1	B
80	UCT216	235	184	26	165	70	51	79,5	21	140	121	32	111	41	70	-	-
	EXT216	235	184	26	165	70	51	79,5	21	140	121	32	111	41	70	-	-
	UCT316	282	230	30	204	102	60	94,0	30	174	160	42	150	53	98	-	-
	EXT316	282	230	30	204	102	60	94,0	30	174	160	42	150	53	98	-	-
	UKT318H	312	255	32	228	110	66	104,5	32	192	175	46	160	57	106	48,0	86,0
85	UCT217	260	198	30	173	73	54	83,5	29	162	157	38	124	48	73	-	-
	EXT217	260	198	30	173	73	54	83,5	29	162	157	38	124	48	73	-	-
	UCT317	298	240	32	214	102	64	98,0	32	183	170	42	152	53	98	-	-
	EXT317	298	240	32	214	102	64	98,0	32	183	170	42	152	53	98	-	-
	UKT319H	322	270	35	240	110	72	107,0	33	197	180	46	165	57	106	52,0	90,0
90	UCT318	312	255	32	228	110	66	104,5	32	192	175	46	160	57	106	-	-
	EXT318	312	255	32	228	110	66	104,5	32	192	175	46	160	57	106	-	-
	UKT320H	345	290	35	260	120	75	110,0	34	210	200	48	175	59	115	54,0	97,0
95	UCT319	322	270	35	240	110	72	107,0	33	197	180	46	165	57	106	-	-
	EXT319	322	270	35	240	110	72	107,0	33	197	180	46	165	57	106	-	-
100	UCT320	345	290	35	260	120	75	110,0	34	210	200	48	175	59	115	-	-
	EXT320	345	290	35	260	120	75	110,0	34	210	200	48	175	59	115	-	-
	UKT322H	385	320	38	285	130	80	127,5	40	235	215	52	185	65	125	61,0	105,0
105	UCT321	347	290	35	260	120	75	112,0	34	212	200	48	175	59	115	-	-
110	UCT322	385	320	38	285	130	80	127,5	40	235	215	52	185	65	125	-	-
	UKT324H	432	355	45	320	140	90	152,0	44	267	230	60	210	70	140	65,0	112,0
115	UKT326H	465	385	50	350	150	100	165,0	47	285	240	65	220	75	150	69,0	121,0
120	UCT324	432	355	45	320	140	90	152,0	44	267	230	60	210	70	140	-	-
125	UKT328H	515	415	50	380	155	100	187,5	52	315	255	70	230	80	160	73,0	131,0
130	UCT326	465	385	50	350	150	100	165,0	47	285	240	65	220	75	150	-	-
140	UCT328	515	415	50	380	155	100	187,5	52	315	255	70	230	80	160	-	-

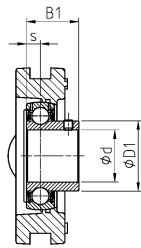

UST200

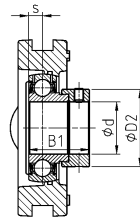

EST200

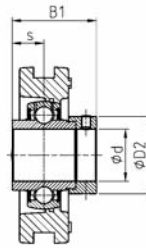
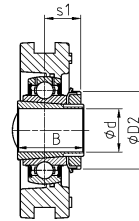
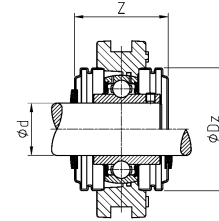
EXT200
EXT300UKT200H
UKT300H

UCT200CO(CC)

B1	s	D1	D2	G	Z	Dz	Gehäuse	Einsatz	Schutzkappe offen *	Schutzkappe geschlossen **	Tragzahl dyn.	Tragzahl stat.	Gewicht	Wellendurch- messer
											C_r [kN]	C_{or} [kN]	[kg]	d [mm]
82,6	33,3	98,0	-	M10x1	-	-	T216	UC216	-	-	72,50	54,20	8,2	80
95,2	37,3	-	110,0	M10x1	-	-	T216	EX216	-	-	72,50	54,20	8,6	80
86,0	34,0	107,9	-	M10x1	-	-	T316	UC316	-	-	122,85	86,50	16,0	80
106,4	40,5	-	119,0	M10x1	-	-	T316	EX316	-	-	122,85	86,50	17,1	80
-	-	-	120,0	M10x1	-	-	T318	UK318 + H2318	-	-	143,00	108,00	21,6	80
85,7	34,1	105,1	-	M10x1	-	-	T217	UC217	-	-	83,20	63,80	10,8	85
73,2	23,4	-	119,0	M10x1	-	-	T217	EX217	-	-	83,20	63,80	11,1	85
96,0	40,0	114,0	-	M10x1	-	-	T317	UC317	-	-	132,60	96,50	18,9	85
109,5	42,0	-	127,0	M10x1	-	-	T317	EX317	-	-	132,60	96,50	20,0	85
-	-	-	125,0	M10x1	-	-	T319	UK319 + H2319	-	-	156,00	122,00	26,2	85
96,0	40,0	120,0	-	M10x1	-	-	T318	UC318	-	-	143,00	108,00	21,5	90
115,9	43,6	-	133,0	M10x1	-	-	T318	EX318	-	-	143,00	108,00	22,7	90
-	-	-	130,0	M10x1	-	-	T320	UK320 + H2320	-	-	171,60	140,00	30,4	90
103,0	41,0	126,5	-	M10x1	-	-	T319	UC319	-	-	156,00	122,00	25,9	95
122,3	46,8	-	140,0	M10x1	-	-	T319	EX319	-	-	156,00	122,00	27,4	95
108,0	42,0	134,5	-	M10x1	-	-	T320	UC320	-	-	171,60	140,00	30,6	100
128,6	50,0	-	146,0	M10x1	-	-	T320	EX320	-	-	171,60	140,00	32,4	100
-	-	-	145,0	M10x1	-	-	T322	UK322 + H2322	-	-	205,00	178,00	41,9	100
112,0	44,0	140,5	-	M10x1	-	-	T321	UC321	-	-	182,00	155,00	31,6	105
117,0	46,0	149,0	-	M10x1	-	-	T322	UC322	-	-	205,00	178,00	38,6	110
-	-	-	155,0	M10x1	-	-	T324	UK324 + H2324	-	-	228,00	208,00	56,6	110
-	-	176,1	165,0	M10x1	-	-	T326	UK326 + H2326	-	-	252,00	242,00	72,7	115
126,0	51,0	163,0	-	M10x1	-	-	T324	UC324	-	-	228,00	208,00	53,9	120
-	-	-	180,0	M10x1	-	-	T328	UK328 + H2328	-	-	275,00	272,00	89,2	125
135,0	54,0	177,0	-	M10x1	-	-	T326	UC326	-	-	252,00	242,00	67,8	130
145,0	59,0	190,0	-	M10x1	-	-	T328	UC328	-	-	275,00	272,00	83,2	140

* = mit zwei offenen Schutzkappen für durchgehende Wellen: Nachsetzzeichen CO wie Bestellbeispiel Seite 6

** = mit einer offenen und einer geschlossenen Schutzkappe für Wellenenden: Nachsetzzeichen CC wie Bestellbeispiel Seite 6

*** = mit Schutzkappen für Einsätze mit Excenterring auf Anfrage lieferbar

Gehäuse T200+WB nachschmierbar

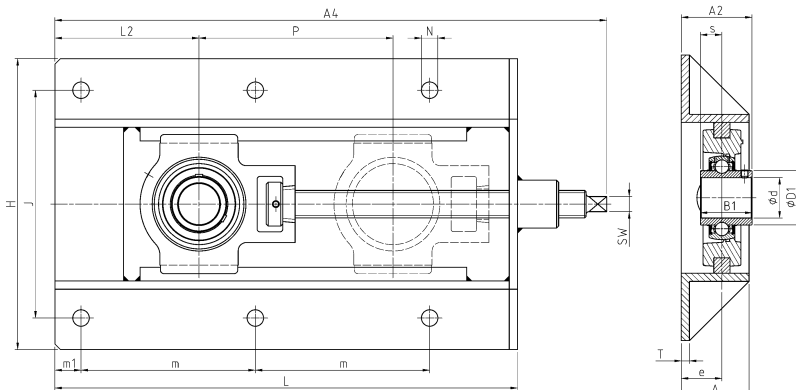
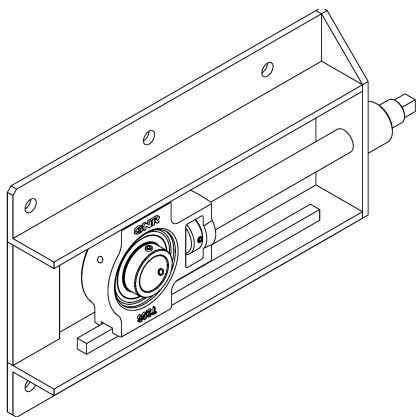

UCT200+WB

Wellendurchmesser
Einheit

Hauptabmessungen in mm

d [mm]		L	H	J	m	m1	A	A2	A4	L2	P	T	e	N	SW	s1	B	B1
12	UCT201+WB	317	199	154	117	19	50	47,3	367	83	150	6	29	12	11	-	-	31,0
	UST201+WB	317	199	154	117	19	50	45,0	367	83	150	6	29	12	11	-	-	22,0
	EST201+WB	317	199	154	117	19	50	51,1	367	83	150	6	29	12	11	-	-	28,6
	EXT201+WB	317	199	154	117	19	50	55,5	367	83	150	6	29	12	11	-	-	43,5
15	UCT202+WB	317	199	154	117	19	50	47,3	367	83	150	6	29	12	11	-	-	31,0
	UST202+WB	317	199	154	117	19	50	45,0	367	83	150	6	29	12	11	-	-	22,0
	EST202+WB	317	199	154	117	19	50	51,1	367	83	150	6	29	12	11	-	-	28,6
	EXT202+WB	317	199	154	117	19	50	55,5	367	83	150	6	29	12	11	-	-	43,5
17	UCT203+WB	317	199	154	117	19	50	47,3	367	83	150	6	29	12	11	-	-	31,0
	UST203+WB	317	199	154	117	19	50	45,0	367	83	150	6	29	12	11	-	-	22,0
	EST203+WB	317	199	154	117	19	50	51,1	367	83	150	6	29	12	11	-	-	28,6
	EXT203+WB	317	199	154	117	19	50	55,5	367	83	150	6	29	12	11	-	-	43,5
20	UCT204+WB	317	199	154	117	19	50	47,3	367	83	150	6	29	12	11	-	-	31,0
	UST204+WB	317	199	154	117	19	50	47,0	367	83	150	6	29	12	11	-	-	25,0
	EST204+WB	317	199	154	117	19	50	52,4	367	83	150	6	29	12	11	-	-	30,9
	EXT204+WB	317	199	154	117	19	50	55,5	367	83	150	6	29	12	11	-	-	43,5
	UKT205H+WB	317	199	154	117	19	50	47,5	368	83	150	6	29	12	11	18,5	35,0	-
25	UCT205+WB	317	199	154	117	19	50	48,7	368	83	150	6	29	12	11	-	-	34,0
	UST205+WB	317	199	154	117	19	50	48,5	368	83	150	6	29	12	11	-	-	27,0
	EST205+WB	317	199	154	117	19	50	52,4	368	83	150	6	29	12	11	-	-	30,9
	EXT205+WB	317	199	154	117	19	50	55,9	368	83	150	6	29	12	11	-	-	44,3
	UKT206H+WB	337	212	166	127	19	50	50,5	396	95	150	6	30	12	11	20,5	38,0	-
30	UCT206+WB	337	212	166	127	19	50	52,2	396	95	150	6	30	12	11	-	-	38,1
	UST206+WB	337	212	166	127	19	50	52,0	396	95	150	6	30	12	11	-	-	30,0
	EST206+WB	337	212	166	127	19	50	56,7	396	95	150	6	30	12	11	-	-	35,7
	EXT206+WB	337	212	166	127	19	50	60,1	396	95	150	6	30	12	11	-	-	48,3
	UKT207H+WB	429	212	166	173	19	50	52,5	490	99	230	6	30	12	12	22,5	43,0	-
35	UCT207+WB	429	212	166	173	19	50	55,4	490	99	230	6	30	12	12	-	-	42,9
	UST207+WB	429	212	166	173	19	50	53,5	490	99	230	6	30	12	12	-	-	32,0
	EST207+WB	429	212	166	173	19	50	59,4	490	99	230	6	30	12	12	-	-	38,9
	EXT207+WB	429	212	166	173	19	50	62,3	490	99	230	6	30	12	12	-	-	51,1
	UKT208H+WB	520	233	192	219	22	50	54,5	591	108	300	6	30	15	15	24,5	46,0	-
40	UCT208+WB	520	233	192	219	22	50	60,2	591	108	300	6	30	15	15	-	-	49,2
	UST208+WB	520	233	192	219	22	50	55,0	591	108	300	6	30	15	15	-	-	34,0
	EST208+WB	520	233	192	219	22	50	62,7	591	108	300	6	30	15	15	-	-	43,7
	EXT208+WB	520	233	192	219	22	50	64,9	591	108	300	6	30	15	15	-	-	56,3
	UKT209H+WB	520	233	192	219	22	50	56,0	590	108	300	6	30	15	15	26,0	50,0	-

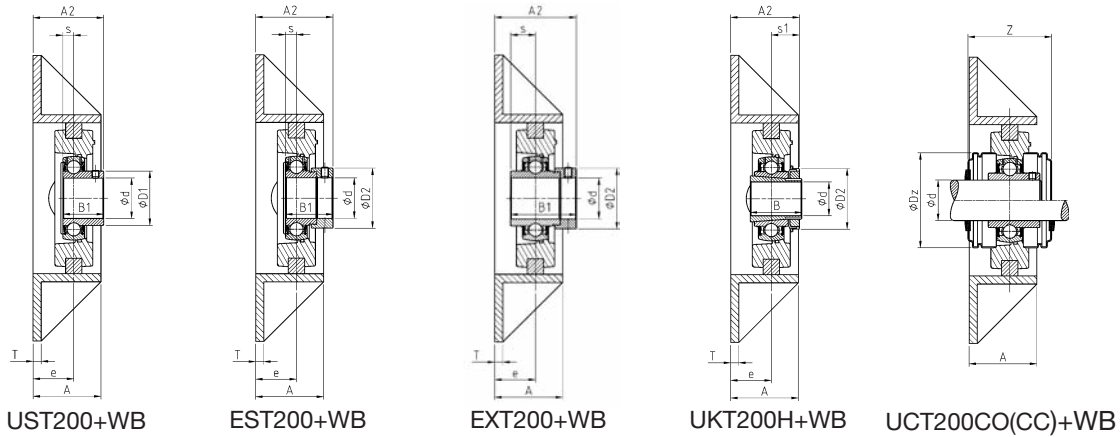

s	D1	D2	Z	Dz	Gehäuse	Einsatz	Spannrahmen	Schutzkappen offen *	Schutzkappen geschlossen **	Tragzahl dyn.	Tragzahl stat.	Gewicht	Wellendurchmesser
										C _r [kN]	C _{or} [kN]	[kg]	d [mm]
12,7	29,0	-	43,7	54,0	T204	UC201	WB205	CO	CC	12,80	6,65	5,2	12
6,0	24,6	-	43,7	46,0	T204	US201	WB205	CO	CC	9,55	4,78	5,1	12
6,5	-	28,6	***	***	T204	ES201	WB205	***	***	9,55	4,78	5,1	12
17,0	-	33,3	***	***	T204	EX201	WB205	***	***	12,80	6,65	5,3	12
12,7	29,0	-	43,7	54,0	T204	UC202	WB205	CO	CC	12,80	6,65	5,2	15
6,0	24,6	-	43,7	46,0	T204	US202	WB205	CO	CC	9,55	4,78	5,1	15
6,5	-	28,6	***	***	T204	ES202	WB205	***	***	9,55	4,78	5,1	15
17,0	-	33,3	***	***	T204	EX202	WB205	***	***	12,80	6,65	5,3	15
12,7	29,0	-	43,7	54,0	T204	UC203	WB205	CO	CC	12,80	6,65	5,2	17
6,0	24,6	-	43,7	46,0	T204	US203	WB205	CO	CC	9,55	4,78	5,1	17
6,5	-	28,6	***	***	T204	ES203	WB205	***	***	9,55	4,78	5,1	17
17,0	-	33,3	***	***	T204	EX203	WB205	***	***	12,80	6,65	5,3	17
12,7	29,0	-	43,7	54,0	T204	UC204	WB205	CO	CC	12,80	6,65	5,2	20
7,0	29,0	-	43,7	54,0	T204	US204	WB205	CO	CC	12,80	6,65	5,1	20
7,5	-	33,3	***	***	T204	ES204	WB205	***	***	12,80	6,65	5,2	20
17,0	-	33,3	***	***	T204	EX204	WB205	***	***	12,80	6,65	5,2	20
-	-	38,0	47,5	60,0	T205	UK205 + H2305	WB205	CO	CC	14,00	7,88	5,2	25
14,3	34,0	-	47,5	60,0	T205	UC205	WB205	CO	CC	14,00	7,88	5,2	25
7,5	34,0	-	47,5	60,0	T205	US205	WB205	CO	CC	14,00	7,88	5,2	25
7,5	-	38,1	***	***	T205	ES205	WB205	***	***	14,00	7,88	5,2	25
17,4	-	38,1	***	***	T205	EX205	WB205	***	***	14,00	7,88	5,3	25
-	-	45,0	52,5	70,0	T206	UK206 + H2306	WB206	CO	CC	19,50	11,20	6,3	30
15,9	40,3	-	52,5	70,0	T206	UC206	WB206	CO	CC	19,50	11,20	6,2	30
8,0	40,3	-	52,5	70,0	T206	US206	WB206	CO	CC	19,50	11,20	6,2	30
9,0	-	44,5	***	***	T206	ES206	WB206	***	***	19,50	11,20	6,2	30
18,2	-	44,5	***	***	T206	EX206	WB206	***	***	19,50	11,20	6,3	30
-	-	52,0	59,1	80,0	T207	UK207 + H2307	WB207	CO	CC	25,70	15,20	8,4	35
17,5	48,0	-	59,1	80,0	T207	UC207	WB207	CO	CC	25,70	15,20	8,4	35
8,5	48,0	-	59,1	80,0	T207	US207	WB207	CO	CC	25,70	15,20	8,3	35
9,5	-	55,6	***	***	T207	ES207	WB207	***	***	25,70	15,20	8,4	35
18,8	-	55,6	***	***	T207	EX207	WB207	***	***	25,70	15,20	8,5	35
-	-	58,0	68,6	88,0	T208	UK208 + H2308	WB210	CO	CC	29,60	18,20	11,8	40
19,0	53,0	-	68,6	88,0	T208	UC208	WB210	CO	CC	29,60	18,20	11,7	40
9,0	53,0	-	68,6	88,0	T208	US208	WB210	CO	CC	29,60	18,20	11,7	40
11,0	-	60,3	***	***	T208	ES208	WB210	***	***	29,60	18,20	11,8	40
21,4	-	60,3	***	***	T208	EX208	WB210	***	***	29,60	18,20	11,9	40
-	-	65,0	68,6	95,0	T209	UK209 + H2309	WB210	CO	CC	31,85	20,80	11,9	40

* = mit zwei offenen Schutzkappen für durchgehende Wellen: Nachsetzzeichen CO wie Bestellbeispiel Seite 6

** = mit einer offenen und einer geschlossenen Schutzkappe für Wellenenden: Nachsetzzeichen CC wie Bestellbeispiel Seite 6

*** = mit Schutzkappen für Einsätze mit Excenterring auf Anfrage lieferbar



Gehäuse T200+WB nachschmierbar

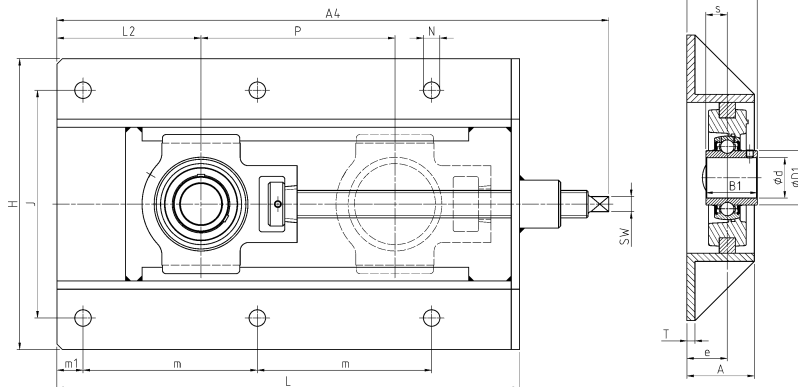
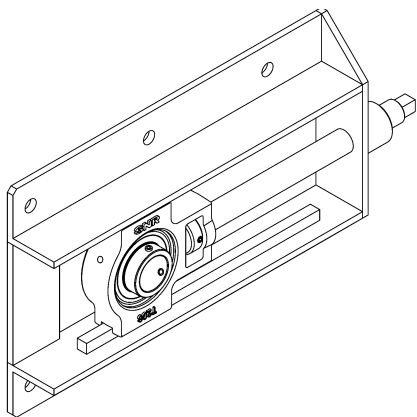

UCT200+WB

Wellendurchmesser
Einheit

Hauptabmessungen in mm

d [mm]		L	H	J	m	m1	A	A2	A4	L2	P	T	e	N	SW	s1	B	B1
45	UCT209+WB	520	233	192	219	22	50	60,2	590	108	300	6	30	15	15	-	-	49,2
	UST209+WB	520	233	192	219	22	50	61,0	590	108	300	6	30	15	15	-	-	41,2
	EST209+WB	520	233	192	219	22	50	62,7	590	108	300	6	30	15	15	-	-	43,7
	EXT209+WB	520	233	192	219	22	50	64,9	590	108	300	6	30	15	15	-	-	56,3
	UKT210H+WB	520	233	192	219	22	50	57,5	593	108	300	6	30	15	15	27,5	55,0	-
50	UCT210+WB	520	233	192	219	22	50	62,6	593	108	300	6	30	15	15	-	-	51,6
	UST210+WB	520	233	192	219	22	50	62,6	593	108	300	6	30	15	15	-	-	43,5
	EST210+WB	520	233	192	219	22	50	62,7	593	108	300	6	30	15	15	-	-	43,7
	EXT210+WB	520	233	192	219	22	50	68,1	593	108	300	6	30	15	15	-	-	62,7
	UKT211H+WB	542	301	240	230	22	65	67,0	631	114	300	6	38	15	19	29,0	59,0	-
55	UCT211+WB	542	301	240	230	22	65	71,4	631	114	300	6	38	15	19	-	-	55,6
	UST211+WB	542	301	240	230	22	65	71,5	631	114	300	6	38	15	19	-	-	45,3
	EST211+WB	542	301	240	230	22	65	74,4	631	114	300	6	38	15	19	-	-	48,4
	EXT211+WB	542	301	240	230	22	65	81,6	631	114	300	6	38	15	19	-	-	71,3
	UKT212H+WB	568	301	240	243	22	65	69,0	651	127	300	6	38	15	19	31,0	62,0	-
60	UCT212+WB	568	301	240	243	22	65	77,7	651	127	300	6	38	15	19	-	-	65,1
	UST212+WB	568	301	240	243	22	65	76,8	651	127	300	6	38	15	19	-	-	53,7
	EST212+WB	568	301	240	243	22	65	75,3	651	127	300	6	38	15	19	-	-	49,3
	EXT212+WB	568	301	240	243	22	65	84,8	651	127	300	6	38	15	19	-	-	77,7
	UKT213H+WB	606	322	260	260	22	65	70,0	699	144	300	6	38	15	24	32,0	65,0	-
65	UCT213+WB	606	322	260	260	22	65	77,7	699	144	300	6	38	15	24	-	-	65,1
	EXT213+WB	606	322	260	260	22	65	89,6	699	144	300	6	38	15	24	-	-	85,7

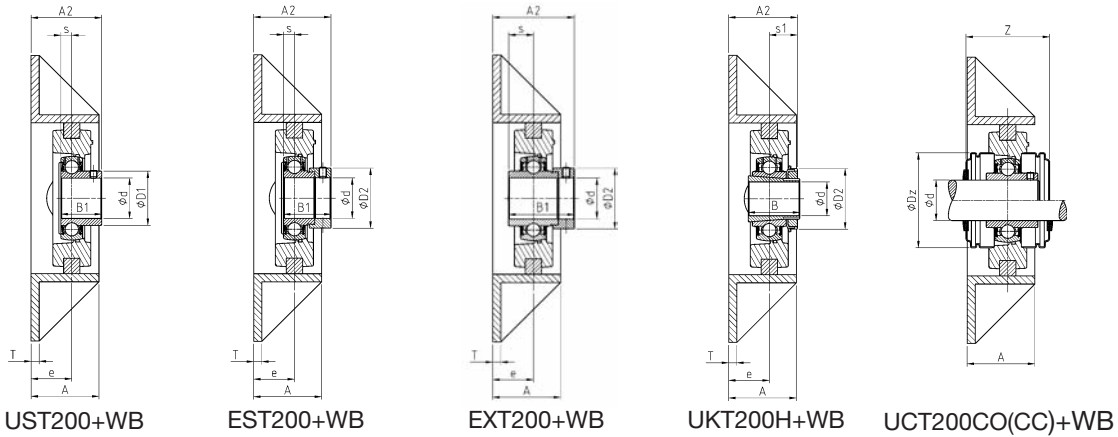

s	D1	D2	Z	Dz	Gehäuse	Einsatz	Spannrahmen	Schutzkappen offen*	Schutzkappen geschlossen**	Tragzahl dyn.	Tragzahl stat.	Gewicht	Wellendurchmesser
										C _r [kN]	C _{or} [kN]	[kg]	d [mm]
19,0	57,2	-	68,6	95,0	T209	UC209	WB210	CO	CC	31,85	20,80	11,8	45
10,2	57,2	-	68,6	95,0	T209	US209	WB210	CO	CC	31,85	20,80	11,8	45
11,0	-	63,5	***	***	T209	ES209	WB210	***	***	31,85	20,80	11,8	45
21,4	-	63,5	***	***	T209	EX209	WB210	***	***	31,85	20,80	12,0	45
-	-	70,0	74,1	100,0	T210	UK210 + H2310	WB210	CO	CC	35,10	23,20	12,2	50
19,0	61,8	-	74,1	100,0	T210	UC210	WB210	CO	CC	35,10	23,20	12,0	50
10,9	61,8	-	74,1	100,0	T210	US210	WB210	CO	CC	35,10	23,20	12,0	50
11,0	-	69,9	***	***	T210	ES210	WB210	***	***	35,10	23,20	12,0	50
24,6	-	69,9	***	***	T210	EX210	WB210	***	***	35,10	23,20	12,2	50
-	-	75,0	75,6	110,0	T211	UK211 + H2311	WB211	CO	CC	43,55	29,20	18,5	55
22,2	69,0	-	75,6	110,0	T211	UC211	WB211	CO	CC	43,55	29,20	18,4	55
11,8	69,0	-	75,6	110,0	T211	US211	WB211	CO	CC	43,55	29,20	18,4	55
12,0	-	76,2	***	***	T211	ES211	WB211	***	***	43,55	29,20	18,2	55
27,7	-	76,2	***	***	T211	EX211	WB211	***	***	43,55	29,20	18,7	55
-	-	80,0	88,6	120,0	T212	UK212 + H2312	WB212	CO	CC	52,50	32,80	20,2	60
25,4	74,9	-	88,6	120,0	T212	UC212	WB212	CO	CC	52,50	32,80	20,2	60
14,9	74,9	-	88,6	120,0	T212	US212	WB212	CO	CC	52,50	32,80	20,0	60
12,0	-	84,2	***	***	T212	ES212	WB212	***	***	52,50	32,80	19,9	60
30,9	-	84,2	***	***	T212	EX212	WB212	***	***	52,50	32,80	20,6	60
-	-	85,0	88,6	132,0	T213	UK213 + H2313	WB213	CO	CC	57,20	40,00	25,3	65
25,4	82,0	-	88,6	132,0	T213	UC213	WB213	CO	CC	57,20	40,00	25,3	65
34,1	-	86,0	***	***	T213	EX213	WB213	***	***	57,20	40,00	25,8	65

* = mit zwei offenen Schutzkappen für durchgehende Wellen: Nachsetzzeichen CO wie Bestellbeispiel Seite 6

** = mit einer offenen und einer geschlossenen Schutzkappe für Wellenenden: Nachsetzzeichen CC wie Bestellbeispiel Seite 6

*** = mit Schutzkappen für Einsätze mit Excenterring auf Anfrage lieferbar

Gehäuse SP200 nachschmierbar

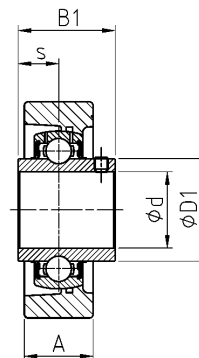
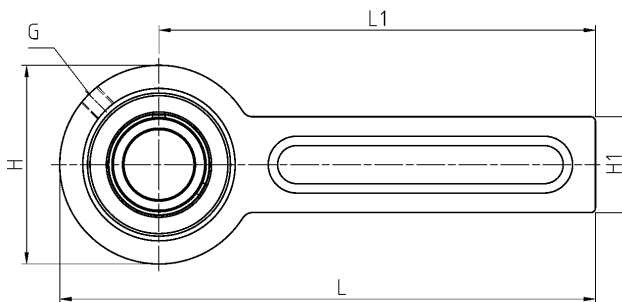
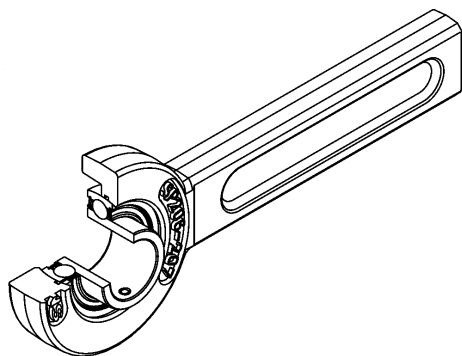

UCSP200

Wellendurchmesser
Einheit

Hauptabmessungen in mm

d [mm]		L	H	L1	H1	A	s1	B	B1	s	D1	D2	G	Z	Dz
12	UCSP201	264	78	225	41	21	-	-	31,0	12,7	29,0	-	R1/8"	48,8	60,0
	USSP201	264	78	225	41	21	-	-	22,0	6,0	24,6	-	R1/8"	48,8	60,0
	ESSP201	264	78	225	41	21	-	-	28,6	6,5	-	28,6	R1/8"	***	***
	EXSP201	264	78	225	41	21	-	-	43,5	17,0	-	33,3	R1/8"	***	***
15	UCSP202	264	78	225	41	21	-	-	31,0	12,7	29,0	-	R1/8"	48,8	60,0
	USSP202	264	78	225	41	21	-	-	22,0	6,0	24,6	-	R1/8"	48,8	60,0
	ESSP202	264	78	225	41	21	-	-	28,6	6,5	-	28,6	R1/8"	***	***
	EXSP202	264	78	225	41	21	-	-	43,5	17,0	-	33,3	R1/8"	***	***
17	UCSP203	264	78	225	41	21	-	-	31,0	12,7	29,0	-	R1/8"	48,8	60,0
	USSP203	264	78	225	41	21	-	-	22,0	6,0	24,6	-	R1/8"	48,8	60,0
	ESSP203	264	78	225	41	21	-	-	28,6	6,5	-	28,6	R1/8"	***	***
	EXSP203	264	78	225	41	21	-	-	43,5	17,0	-	33,3	R1/8"	***	***
20	UCSP204	264	78	225	41	21	-	-	31,0	12,7	29,0	-	R1/8"	48,8	60,0
	USSP204	264	78	225	41	21	-	-	25,0	7,0	29,0	-	R1/8"	48,8	60,0
	ESSP204	264	78	225	41	21	-	-	30,9	7,5	-	33,3	R1/8"	***	***
	EXSP204	264	78	225	41	21	-	-	43,5	17,0	-	33,3	R1/8"	***	***
	UKSP205H	264	78	225	41	21	18,5	35,0	-	-	-	38,0	R1/8"	48,8	60,0
25	UCSP205	264	78	225	41	21	-	-	34,0	14,3	34,0	-	R1/8"	48,8	60,0
	USSP205	264	78	225	41	21	-	-	27,0	7,5	34,0	-	R1/8"	48,8	60,0
	ESSP205	264	78	225	41	21	-	-	30,9	7,5	-	38,1	R1/8"	***	***
	EXSP205	264	78	225	41	21	-	-	44,3	17,4	-	38,1	R1/8"	***	***
	UKSP206H	274	98	225	41	21	20,5	38,0	-	-	-	45,0	R1/8"	58,4	80,0
30	UCSP206	274	98	225	41	21	-	-	38,1	15,9	40,3	-	R1/8"	58,4	80,0
	USSP206	274	98	225	41	21	-	-	30,0	8,0	40,3	-	R1/8"	58,4	80,0
	ESSP206	274	98	225	41	21	-	-	35,7	9,0	-	44,5	R1/8"	***	***
	EXSP206	274	98	225	41	21	-	-	48,3	18,2	-	44,5	R1/8"	***	***
	UKSP207H	274	98	225	41	21	22,5	43,0	-	-	-	52,0	R1/8"	58,4	80,0
35	UCSP207	274	98	225	41	21	-	-	42,9	17,5	48,0	-	R1/8"	58,4	80,0
	USSP207	274	98	225	41	21	-	-	32,0	8,5	48,0	-	R1/8"	58,4	80,0
	ESSP207	274	98	225	41	21	-	-	38,9	9,5	-	55,6	R1/8"	***	***
	EXSP207	274	98	225	41	21	-	-	51,1	18,8	-	55,6	R1/8"	***	***
	UKSP208H	320	120	260	61	31	24,5	46,0	-	-	-	58,0	R1/8"	75,6	100,0
40	UCSP208	320	120	260	61	31	-	-	49,2	19,0	53,0	-	R1/8"	75,6	100,0
	USSP208	320	120	260	61	31	-	-	34,0	9,0	53,0	-	R1/8"	75,6	100,0
	ESSP208	320	120	260	61	31	-	-	43,7	11,0	-	60,3	R1/8"	***	***
	EXSP208	320	120	260	61	31	-	-	56,3	21,4	-	60,3	R1/8"	***	***
	UKSP209H	320	120	260	61	31	26,0	50,0	-	-	-	65,0	R1/8"	75,6	100,0

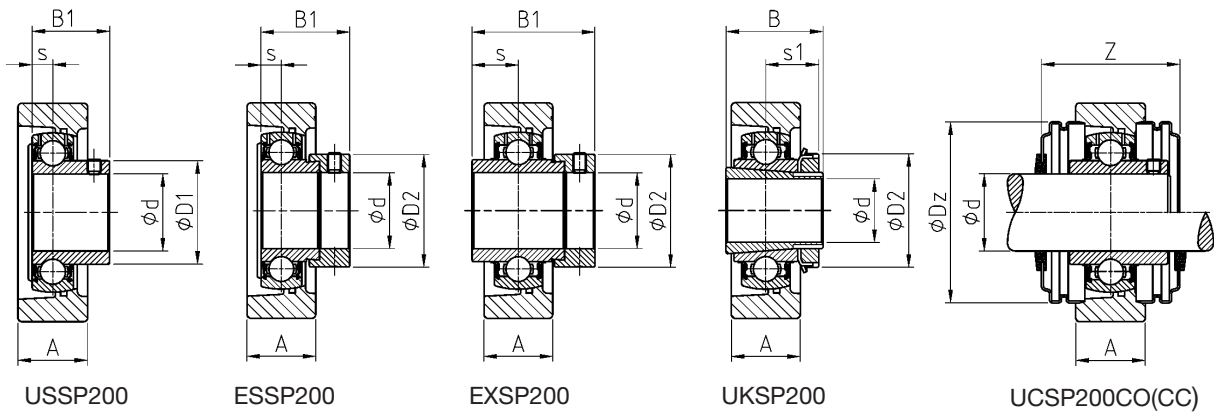

USSP200

ESSP200

EXSP200

UKSP200

UCSP200CO(CC)

Gehäuse

Einsatz

Spann-
rahmen ****
(Seite 136)Schutzkappen
offen *Schutzkappen
geschlossen **Tragzahl
dyn.Tragzahl
stat.

Gewicht

Wellendurch-
messer

								C_r [kN]	C_{or} [kN]	[kg]	d [mm]
203-205/47	UC201	SPR1	SPR11	SPR12	SPR14	CO	CC	12,80	6,65	1,7	12
03-205/40	US201	SPR1	SPR11	SPR12	SPR14	CO	CC	9,55	4,78	1,6	
03-205/40	ES201	SPR1	SPR11	SPR12	SPR14	***	***	9,55	4,78	1,6	
03-205/47	EX201	SPR1	SPR11	SPR12	SPR14	***	***	12,80	6,65	1,8	
03-205/47	UC202	SPR1	SPR11	SPR12	SPR14	CO	CC	12,80	6,65	1,7	15
03-205/40	US202	SPR1	SPR11	SPR12	SPR14	CO	CC	9,55	4,78	1,6	
03-205/40	ES202	SPR1	SPR11	SPR12	SPR14	***	***	9,55	4,78	1,6	
03-205/47	EX202	SPR1	SPR11	SPR12	SPR14	***	***	12,80	6,65	1,8	
03-205/47	UC203	SPR1	SPR11	SPR12	SPR14	CO	CC	12,80	6,65	1,7	17
03-205/40	US203	SPR1	SPR11	SPR12	SPR14	CO	CC	9,55	4,78	1,6	
03-205/40	ES203	SPR1	SPR11	SPR12	SPR14	***	***	9,55	4,78	1,6	
03-205/47	EX203	SPR1	SPR11	SPR12	SPR14	***	***	12,80	6,65	1,8	
03-205/47	UC204	SPR1	SPR11	SPR12	SPR14	CO	CC	12,80	6,65	1,7	20
03-205/40	US204	SPR1	SPR11	SPR12	SPR14	CO	CC	12,80	6,65	1,6	
03-205/40	ES204	SPR1	SPR11	SPR12	SPR14	***	***	12,80	6,65	1,7	
03-205/47	EX204	SPR1	SPR11	SPR12	SPR14	***	***	12,80	6,65	1,7	
03-205/52	UK205 + H2305	SPR1	SPR11	SPR12	SPR14	CO	CC	14,00	7,88	1,7	
03-205/52	UC205	SPR1	SPR11	SPR12	SPR14	CO	CC	14,00	7,88	1,7	25
03-205/52	US205	SPR1	SPR11	SPR12	SPR14	CO	CC	14,00	7,88	1,7	
03-205/52	ES205	SPR1	SPR11	SPR12	SPR14	***	***	14,00	7,88	1,7	
03-205/52	EX205	SPR1	SPR11	SPR12	SPR14	***	***	14,00	7,88	1,8	
06-207/62	UK206 + H2306	SPR1	SPR11	SPR12	SPR14	CO	CC	19,50	11,20	2,0	
06-207/62	UC206	SPR1	SPR11	SPR12	SPR14	CO	CC	19,50	11,20	1,9	30
06-207/62	US206	SPR1	SPR11	SPR12	SPR14	CO	CC	19,50	11,20	1,9	
06-207/62	ES206	SPR1	SPR11	SPR12	SPR14	***	***	19,50	11,20	1,9	
06-207/62	EX206	SPR1	SPR11	SPR12	SPR14	***	***	19,50	11,20	2,0	
06-207/72	UK207 + H2307	SPR1	SPR11	SPR12	SPR14	CO	CC	25,70	15,20	2,1	
06-207/72	UC207	SPR1	SPR11	SPR12	SPR14	CO	CC	25,70	15,20	2,1	35
06-207/72	US207	SPR1	SPR11	SPR12	SPR14	CO	CC	25,70	15,20	2,0	
06-207/72	ES207	SPR1	SPR11	SPR12	SPR14	***	***	25,70	15,20	2,1	
06-207/72	EX207	SPR1	SPR11	SPR12	SPR14	***	***	25,70	15,20	2,2	
08-210/80	UK208 + H2308	SPR2	SPR21	SPR22	SPR24	CO	CC	29,60	18,20	4,3	
08-210/80	UC208	SPR2	SPR21	SPR22	SPR24	CO	CC	29,60	18,20	4,2	40
08-210/80	US208	SPR2	SPR21	SPR22	SPR24	CO	CC	29,60	18,20	4,2	
08-210/80	ES208	SPR2	SPR21	SPR22	SPR24	***	***	29,60	18,20	4,2	
08-210/80	EX208	SPR2	SPR21	SPR22	SPR24	***	***	29,60	18,20	4,3	
08-210/85	UK209 + H2309	SPR2	SPR21	SPR22	SPR24	CO	CC	31,85	20,80	4,3	

* = mit zwei offenen Schutzkappen für durchgehende Wellen: Nachsetzzeichen CO wie Bestellbeispiel Seite 6

** = mit einer offenen und einer geschlossenen Schutzkappe für Wellenenden: Nachsetzzeichen CC wie Bestellbeispiel Seite 6

*** = mit Schutzkappen für Einsätze mit Excenterring auf Anfrage lieferbar

**** = müssen separat bestellt werden.

Gehäuse SP200 nachschmierbar

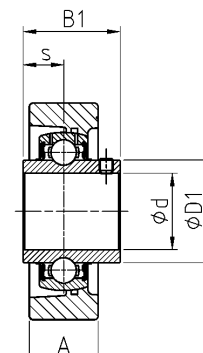
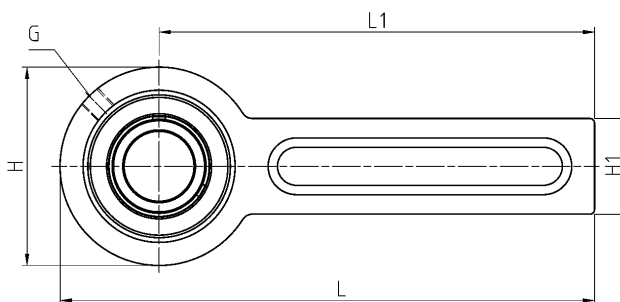
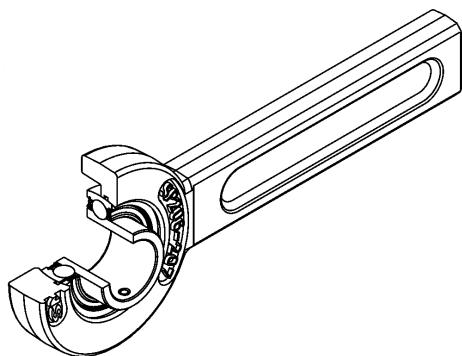

UCSP200

Wellendurchmesser		Einheit		Hauptabmessungen in mm												
d [mm]		L	H	L1	H1	A	s1	B	B1	s	D1	D2	G	Z	Dz	
45	UCSP209	320	120	260	61	31	-	-	49,2	19,0	57,2	-	R1/8"	75,6	100,0	
	USSP209	320	120	260	61	31	-	-	41,2	10,2	57,2	-	R1/8"	75,6	100,0	
	ESSP209	320	120	260	61	31	-	-	43,7	11,0	-	63,5	R1/8"	***	***	
	EXSP209	320	120	260	61	31	-	-	56,3	21,4	-	63,5	R1/8"	***	***	
	UKSP210H	320	120	260	61	31	27,5	55,0	-	-	-	70,0	R1/8"	75,6	100,0	
50	UCSP210	320	120	260	61	31	-	-	51,6	19,0	61,8	-	R1/8"	75,6	100,0	
	USSP210	320	120	260	61	31	-	-	43,5	10,9	61,8	-	R1/8"	75,6	100,0	
	ESSP210	320	120	260	61	31	-	-	43,7	11,0	-	69,9	R1/8"	***	***	
	EXSP210	320	120	260	61	31	-	-	62,7	24,6	-	69,9	R1/8"	***	***	

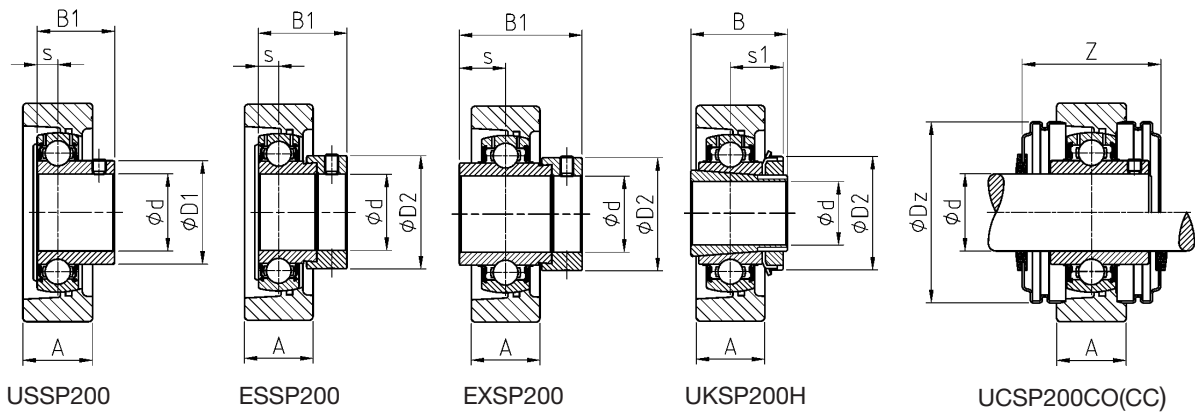

Gehäuse / Einsatz / Spannrahmen **** (Seite 136) / Schutzkappen offen * / Schutzkappen geschlossen ** / Tragzahl dyn. / Tragzahl stat. / Gewicht / Wellendurchmesser

								C_r	C_{or}		d
								[kN]	[kN]	[kg]	[mm]
08-210/85	UC209	SPR2	SPR21	SPR22	SPR24	CO	CC	31,85	20,80	4,2	45
08-210/85	US209	SPR2	SPR21	SPR22	SPR24	CO	CC	31,85	20,80	4,2	
08-210/85	ES209	SPR2	SPR21	SPR22	SPR24	***	***	31,85	20,80	4,2	
08-210/85	EX209	SPR2	SPR21	SPR22	SPR24	***	***	31,85	20,80	4,4	
08-210/90	UK210 + H2310	SPR2	SPR21	SPR22	SPR24	CO	CC	35,10	23,20	4,4	50
08-210/90	UC210	SPR2	SPR21	SPR22	SPR24	CO	CC	35,10	23,20	4,2	
08-210/90	US210	SPR2	SPR21	SPR22	SPR24	CO	CC	35,10	23,20	4,2	
08-210/90	ES210	SPR2	SPR21	SPR22	SPR24	***	***	35,10	23,20	4,2	
08-210/90	EX210	SPR2	SPR21	SPR22	SPR24	***	***	35,10	23,20	4,4	

* = mit zwei offenen Schutzkappen für durchgehende Wellen: Nachsetzzeichen CO wie Bestellbeispiel Seite 6
 ** = mit einer offenen und einer geschlossenen Schutzkappe für Wellenenden: Nachsetzzeichen CC wie Bestellbeispiel Seite 6
 *** = mit Schutzkappen für Einsätze mit Excenterring auf Anfrage lieferbar
 **** = müssen separat bestellt werden.

Gehäuse SPR

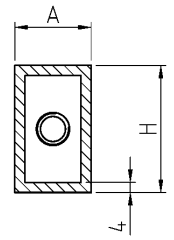
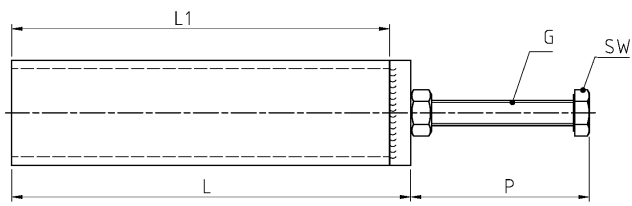
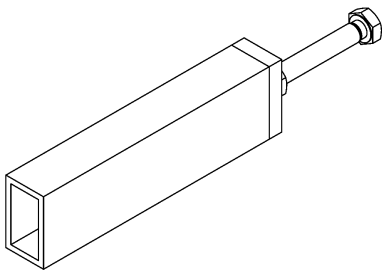

SPR1+2

Wellendurchmesser	Kurzzeichen	für Gehäuse	Hauptabmessungen in mm					
d			L	L1	H	H2	m	m1
	SPR1	SP203-207	190	180	50	-	-	-
	SPR2	SP208-210	225	210	70	-	-	-
	SPR11	SP203-207	190	180	50	100	130	80
	SPR21	SP208-210	225	210	70	140	160	100
	SPR12	SP203-207	190	180	48	100	65	75
	SPR22	SP208-210	225	210	68	130	80	100
	SPR14	SP203-207	190	180	48	103	140	80
	SPR24	SP208-210	235	220	68	130	180	100

Hauptabmessungen in mm

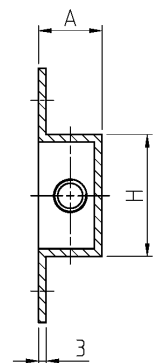
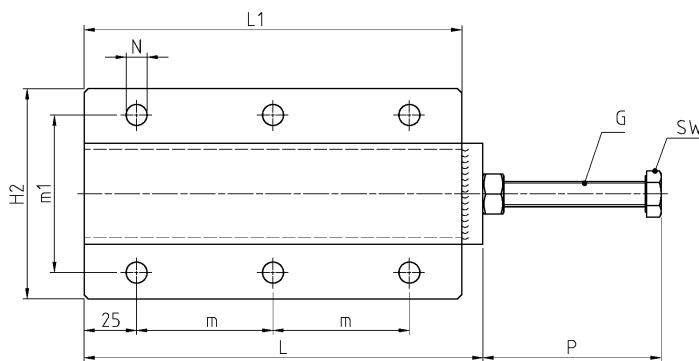
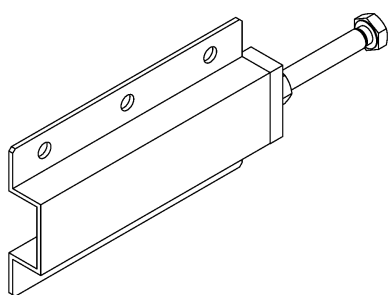

SPR12+22

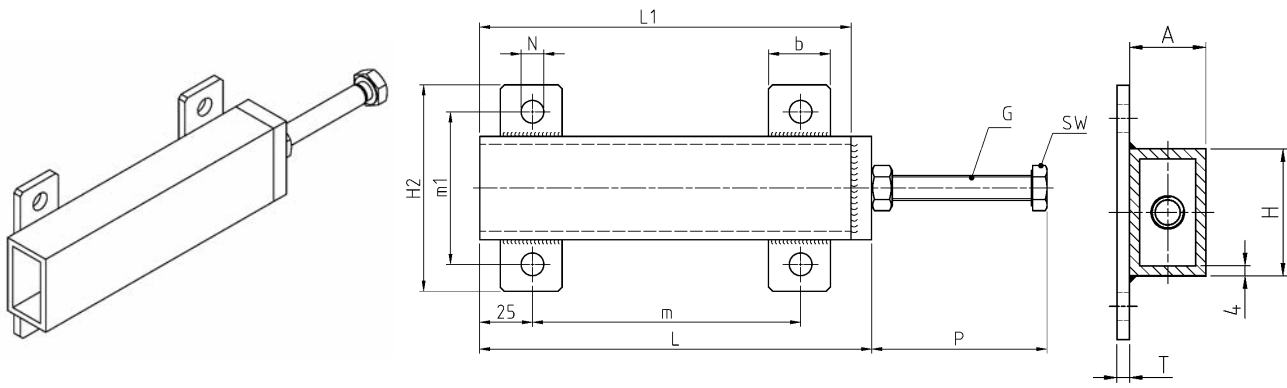

SPR11+21

A	b	T	P _{max}	G	N	SW
30	-	-	85	M12x90	-	18
40	-	-	105	M16x110	-	24
30	30	5	85	M12x90	11,0	18
40	40	6	105	M16x110	14,0	24
25	-	-	85	M12x90	10,0	18
35	-	-	105	M16x110	12,0	24
25	-	-	97	M12x100	11,5	18
35	-	-	111	M16x120	14,0	24

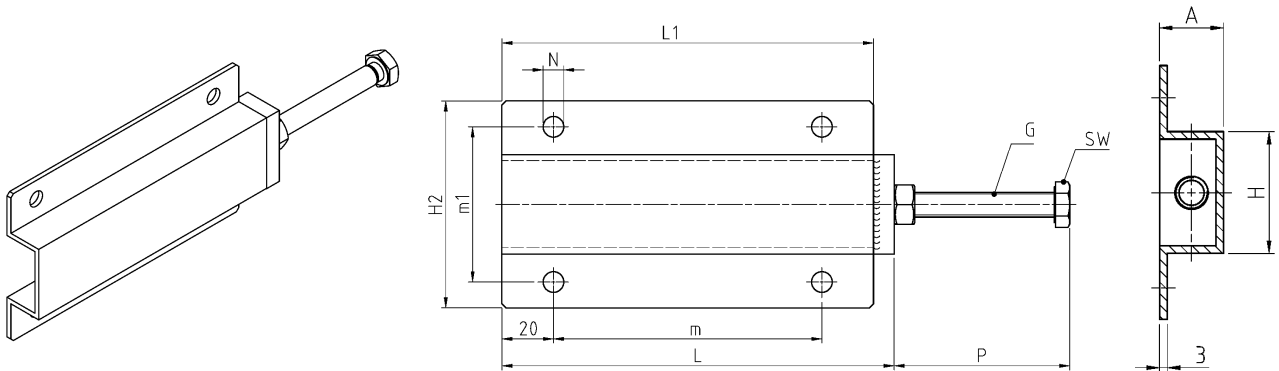

SPR14+24

Gehäuse C200 nachschmierbar
C300 nachschmierbar

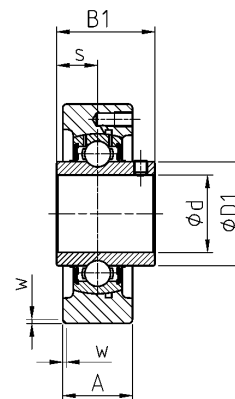
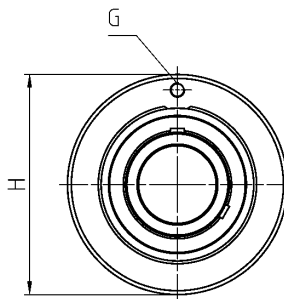
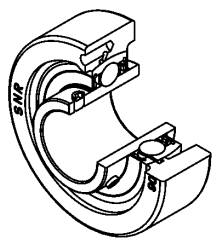

UCC200
UCC300

Wellendurchmesser
Einheit

Hauptabmessungen in mm

d [mm]		H h7	A	w	s1	B	B1	s
12	UCC201	72	20	1,5	-	-	31,0	12,7
	USC201	67	20	1,5	-	-	22,0	6,0
	ESC201	67	20	1,5	-	-	28,6	6,5
	EXC201	72	20	1,5	-	-	43,5	17,0
15	UCC202	72	20	1,5	-	-	31,0	12,7
	USC202	67	20	1,5	-	-	22,0	6,0
	ESC202	67	20	1,5	-	-	28,6	6,5
	EXC202	72	20	1,5	-	-	43,5	17,0
17	UCC203	72	20	1,5	-	-	31,0	12,7
	USC203	67	20	1,5	-	-	22,0	6,0
	ESC203	67	20	1,5	-	-	28,6	6,5
	EXC203	72	20	1,5	-	-	43,5	17,0
20	UCC204	72	20	1,5	-	-	31,0	12,7
	USC204	72	20	1,5	-	-	25,0	7,0
	ESC204	72	20	1,5	-	-	30,9	7,5
	EXC204	72	20	1,5	-	-	43,5	17,0
	UKC205H	80	22	1,5	18,5	35,0	-	-
	UKC305H	90	26	2,5	21,5	35,0	-	-
25	UCC205	80	22	1,5	-	-	34,0	14,3
	USC205	80	22	1,5	-	-	27,0	7,5
	ESC205	80	22	1,5	-	-	30,9	7,5
	EXC205	80	22	1,5	-	-	44,3	17,4
	UKC206H	85	27	1,5	20,5	38,0	-	-
	UCC305	90	26	2,5	-	-	38,0	15,0
	EXC305	90	26	2,5	-	-	46,8	16,7
	UKC306H	100	28	2,5	23,0	38,0	-	-
	30	UCC206	85	27	1,5	-	-	38,1
USC206		85	27	1,5	-	-	30,0	8,0
ESC206		85	27	1,5	-	-	35,7	9,0
EXC206		85	27	1,5	-	-	48,3	18,2
UKC207H		90	28	2,0	22,5	43,0	-	-
UCC306		100	28	2,5	-	-	43,0	17,0
EXC306		100	28	2,5	-	-	50,0	17,5
UKC307H		110	32	3,0	25,5	43,0	-	-

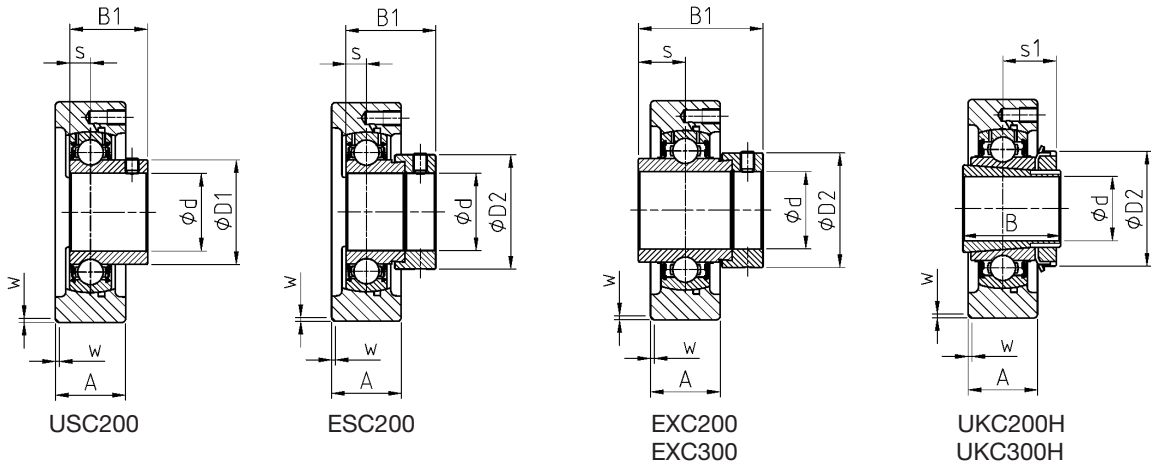

Gehäuse

Einsatz

Tragzahl
dyn.

Tragzahl
stat.

Gewicht

Wellendurch-
messer

D1	D2	G			C_r [kN]	C_{or} [kN]	[kg]	d [mm]
29,0	-	M6x1	C204	UC201	12,80	6,65	0,5	12
24,6	-	M6x1	C203	US201	9,55	4,78	0,4	
-	28,6	M6x1	C203	ES201	9,55	4,78	0,4	
-	33,3	M6x1	C204	EX201	12,80	6,65	0,6	
29,0	-	M6x1	C204	UC202	12,80	6,65	0,5	15
24,6	-	M6x1	C203	US202	9,55	4,78	0,4	
-	28,6	M6x1	C203	ES202	9,55	4,78	0,4	
-	33,3	M6x1	C204	EX202	12,80	6,65	0,6	
29,0	-	M6x1	C204	UC203	12,80	6,65	0,5	17
24,6	-	M6x1	C203	US203	9,55	4,78	0,4	
-	28,6	M6x1	C203	ES203	9,55	4,78	0,4	
-	33,3	M6x1	C204	EX203	12,80	6,65	0,6	
29,0	-	M6x1	C204	UC204	12,80	6,65	0,5	20
29,0	-	M6x1	C204	US204	12,80	6,65	0,5	
-	33,3	M6x1	C204	ES204	12,80	6,65	0,5	
-	33,3	M6x1	C204	EX204	12,80	6,65	0,5	
-	38,0	M6x1	C205	UK205 + H2305	14,00	7,88	0,7	
35,4	38,0	M6x1	C305	UK305 + H2305	22,36	11,50	1,5	25
34,0	-	M6x1	C205	UC205	14,00	7,88	0,7	
34,0	-	M6x1	C205	US205	14,00	7,88	0,7	
-	38,1	M6x1	C205	ES205	14,00	7,88	0,7	
-	38,1	M6x1	C205	EX205	14,00	7,88	0,7	
-	45,0	M6x1	C206	UK206 + H2306	19,50	11,20	1,0	
35,4	-	M6x1	C305	UC305	22,36	11,50	1,4	
-	42,8	M6x1	C305	EX305	22,36	11,50	1,4	
-	45,0	M6x1	C306	UK306 + H2306	27,00	15,20	1,7	30
40,3	-	M6x1	C206	UC206	19,50	11,20	1,0	
40,3	-	M6x1	C206	US206	19,50	11,20	0,9	
-	44,5	M6x1	C206	ES206	19,50	11,20	1,0	
-	44,5	M6x1	C206	EX206	19,50	11,20	1,1	
-	52,0	M6x1	C207	UK207 + H2307	25,70	15,20	1,1	
44,6	-	M6x1	C306	UC306	27,00	15,20	1,7	
-	50,0	M6x1	C306	EX306	27,00	15,20	1,8	
-	52,0	M6x1	C307	UK307 + H2307	33,50	19,20	1,9	

Gehäuse

C200 nachschmierbar
C300 nachschmierbar

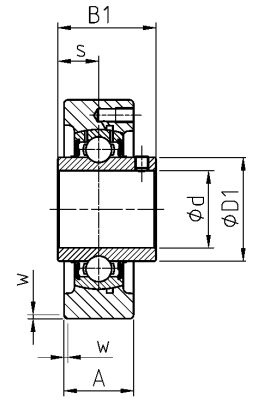
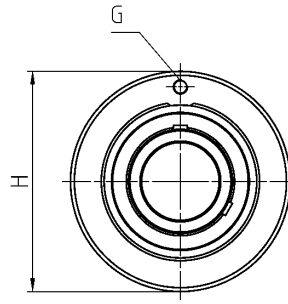
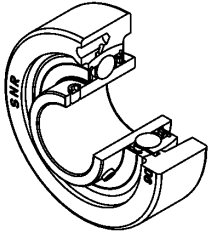

UCC200
UCC300

Wellendurchmesser
Einheit

Hauptabmessungen in mm

d [mm]		H h7	A	w	s1	B	B1	s
35	UCC207	90	28	2,0	-	-	42,9	17,5
	USC207	90	28	2,0	-	-	32,0	8,5
	ESC207	90	28	2,0	-	-	38,9	9,5
	EXC207	90	28	2,0	-	-	51,1	18,8
	UKC208H	100	30	2,0	24,5	46,0	-	-
	UCC307	110	32	3,0	-	-	48,0	19,0
	EXC307	110	32	3,0	-	-	51,6	18,3
	UKC308H	120	34	3,0	27,5	46,0	-	-
	40	UCC208	100	30	2,0	-	-	49,2
USC208		100	30	2,0	-	-	34,0	9,0
ESC208		100	30	2,0	-	-	43,7	11,0
EXC208		100	30	2,0	-	-	56,3	21,4
UKC209H		110	31	2,0	26,0	50,0	-	-
UCC308		120	34	3,0	-	-	52,0	19,0
EXC308		120	34	3,0	-	-	57,1	19,8
UKC309H		130	38	3,5	30,0	50,0	-	-
45		UCC209	110	31	2,0	-	-	49,2
	USC209	110	31	2,0	-	-	41,2	10,2
	ESC209	110	31	2,0	-	-	43,7	11,0
	EXC209	110	31	2,0	-	-	56,3	21,4
	UKC210H	120	33	2,0	27,5	55,0	-	-
	UCC309	130	38	3,5	-	-	57,0	22,0
	EXC309	130	38	3,5	-	-	58,7	19,8
	UKC310H	140	40	3,5	32,0	55,0	-	-
	50	UCC210	120	33	2,0	-	-	51,6
USC210		120	33	2,0	-	-	43,5	10,9
ESC210		120	33	2,0	-	-	43,7	11,0
EXC210		120	33	2,0	-	-	62,7	24,6
UKC211H		125	35	2,5	29,0	59,0	-	-
UCC310		140	40	3,5	-	-	61,0	22,0
EXC310		140	40	3,5	-	-	66,6	24,6
UKC311H		150	44	3,5	34,0	59,0	-	-

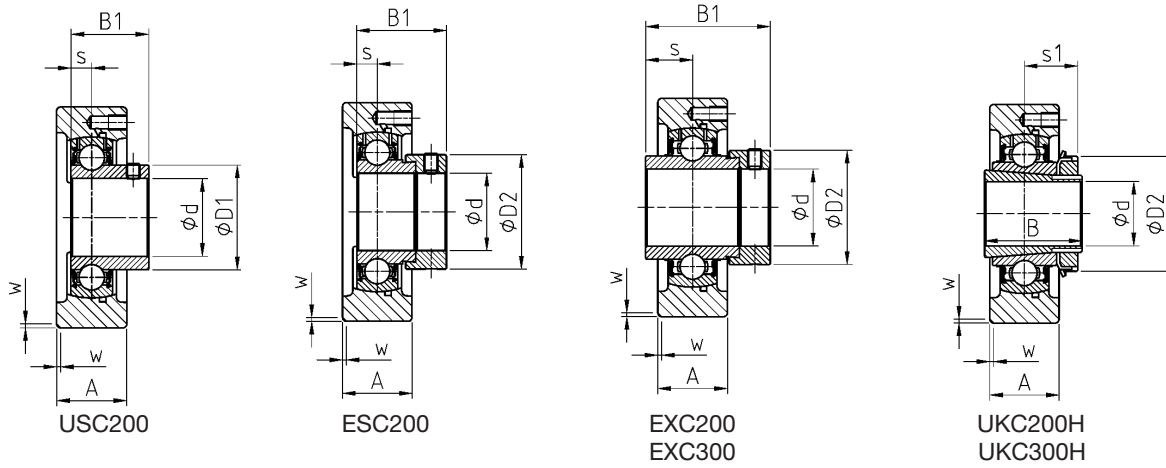

Gehäuse *Einsatz* *Tragzahl dyn.* *Tragzahl stat.* *Gewicht* *Wellendurchmesser*

D1	D2	G			C _r [kN]	C _{or} [kN]	[kg]	d [mm]
48,0	-	M6x1	C207	UC207	25,70	15,20	1,1	35
48,0	-	M6x1	C207	US207	25,70	15,20	1,0	
-	55,6	M6x1	C207	ES207	25,70	15,20	1,1	
-	55,6	M6x1	C207	EX207	25,70	15,20	1,2	
-	58,0	M6x1	C208	UK208 + H2308	29,60	18,20	1,4	
48,9	-	M6x1	C307	UC307	33,50	19,20	1,7	
-	55,0	M6x1	C307	EX307	33,50	19,20	1,8	
-	58,0	M6x1	C308	UK308 + H2308	40,56	24,00	2,1	
53,0	-	M6x1	C208	UC208	29,60	18,20	1,3	40
53,0	-	M6x1	C208	US208	29,60	18,20	1,3	
-	60,3	M6x1	C208	ES208	29,60	18,20	1,4	
-	60,3	M6x1	C208	EX208	29,60	18,20	1,5	
-	65,0	M6x1	C209	UK209 + H2309	31,85	20,80	1,6	
56,5	-	M6x1	C308	UC308	40,56	24,00	2,1	
-	63,5	M6x1	C308	EX308	40,56	24,00	2,2	
-	65,0	M6x1	C309	UK309 + H2309	53,00	31,80	3,1	
57,2	-	M6x1	C209	UC209	31,85	20,80	1,5	45
57,2	-	M6x1	C209	US209	31,85	20,80	1,5	
-	63,5	M6x1	C209	ES209	31,85	20,80	1,5	
-	63,5	M6x1	C209	EX209	31,85	20,80	1,7	
-	70,0	M6x1	C210	UK210 + H2310	35,10	23,20	2,1	
61,8	-	M6x1	C309	UC309	53,00	31,80	2,9	
-	70,0	M6x1	C309	EX309	53,00	31,80	3,1	
-	70,0	M6x1	C310	UK310 + H2310	62,00	37,80	3,3	
61,8	-	M6x1	C210	UC210	35,10	23,20	1,9	50
61,8	-	M6x1	C210	US210	35,10	23,20	1,9	
-	69,9	M6x1	C210	ES210	35,10	23,20	1,9	
-	69,9	M6x1	C210	EX210	35,10	23,20	2,1	
-	75,0	M6x1	C211	UK211 + H2311	43,55	29,20	2,3	
68,7	-	M6x1	C310	UC310	62,00	37,80	3,3	
-	76,2	M6x1	C310	EX310	62,00	37,80	3,5	
-	75,0	M6x1	C311	UK311 + H2311	71,50	44,80	4,2	



Gehäuse C200 nachschmierbar
C300 nachschmierbar

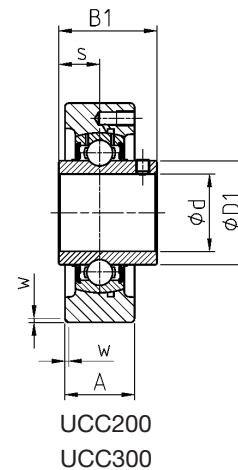
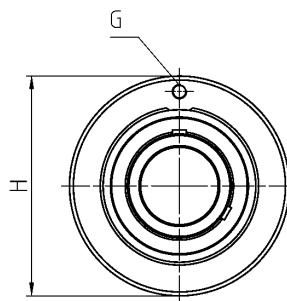
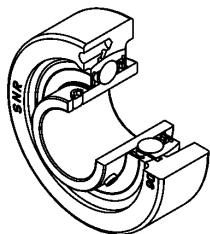

Wellendurchmesser
Einheit

Hauptabmessungen in mm

d [mm]		H h7	A	w	s1	B	B1	s
55	UCC211	125	35	2,5	-	-	55,6	22,2
	USC211	125	35	2,5	-	-	45,3	11,8
	ESC211	125	35	2,5	-	-	48,4	12,0
	EXC211	125	35	2,5	-	-	71,3	27,7
	UKC212H	130	38	2,5	31,0	62,0	-	-
	UCC311	150	44	3,5	-	-	66,0	25,0
	EXC311	150	44	3,5	-	-	73,0	27,8
	UKC312H	160	46	3,5	36,5	62,0	-	-
60	UCC212	130	38	2,5	-	-	65,1	25,4
	USC212	130	38	2,5	-	-	53,7	14,9
	ESC212	130	38	2,5	-	-	49,3	12,0
	EXC212	130	38	2,5	-	-	77,7	30,9
	UKC213H	140	40	2,5	32,0	65,0	-	-
	UCC312	160	46	3,5	-	-	71,0	26,0
	EXC312	160	46	3,5	-	-	79,4	31,0
	UKC313H	170	50	3,5	38,5	65,0	-	-
65	UCC213	140	40	2,5	-	-	65,1	25,4
	EXC213	140	40	2,5	-	-	85,7	34,1
	UKC215H	160	44	2,0	35,5	73,0	-	-
	UCC313	170	50	3,5	-	-	75,0	30,0
	EXC313	170	50	3,5	-	-	85,7	32,5
	UKC315H	190	55	4,0	42,5	73,0	-	-
70	UCC214	150	44	2,0	-	-	74,6	30,2
	EXC214	150	44	2,0	-	-	85,7	34,1
	UKC216H	170	48	2,0	39,0	78,0	-	-
	UCC314	180	52	4,0	-	-	78,0	33,0
	EXC314	180	52	4,0	-	-	92,1	34,2
	UKC316H	200	60	4,0	44,5	78,0	-	-
75	UCC215	160	44	2,0	-	-	77,8	33,3
	EXC215	160	44	2,0	-	-	92,1	37,3
	UCC315	190	55	4,0	-	-	82,0	32,0
	EXC315	190	55	4,0	-	-	100,0	37,3
	UKC317H	215	64	4,0	48,0	82,0	-	-

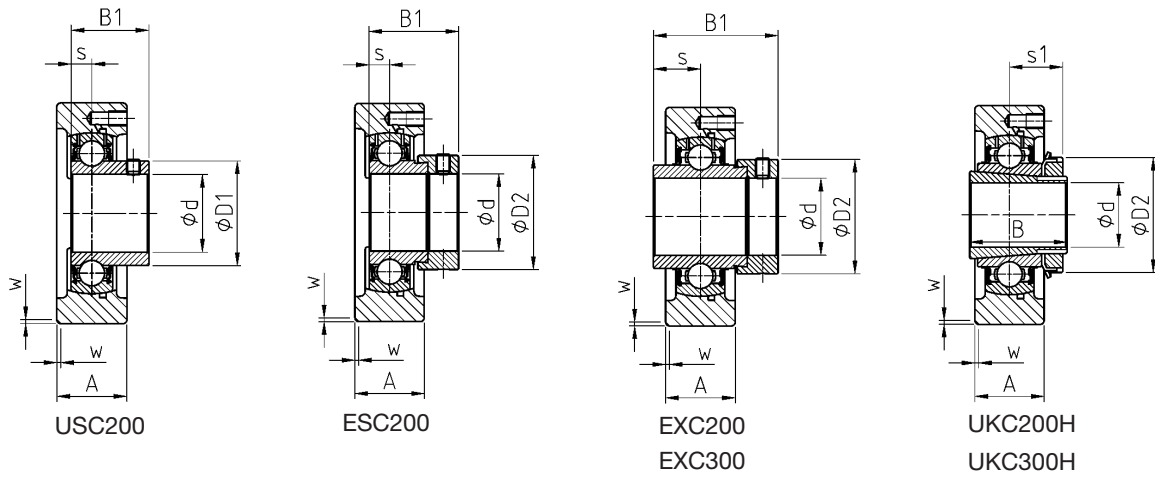

Gehäuse *Einsatz* *Tragzahl dyn.* *Tragzahl stat.* *Gewicht* *Wellendurchmesser*

D1	D2	G			C _r [kN]	C _{or} [kN]	[kg]	d [mm]
69,0	-	M6x1	C211	UC211	43,55	29,20	2,3	55
69,0	-	M6x1	C211	US211	43,55	29,20	2,2	
-	76,2	M6x1	C211	ES211	43,55	29,20	2,0	
-	76,2	M6x1	C211	EX211	43,55	29,20	2,5	
-	80,0	M6x1	C212	UK212 + H2312	52,50	32,80	2,7	
74,9	-	M6x1	C311	UC311	71,50	44,80	3,9	60
-	83,0	M6x1	C311	EX311	71,50	44,80	4,3	
-	80,0	M6x1	C312	UK312 + H2312	81,60	51,80	4,6	
74,9	-	M6x1	C212	UC212	52,50	32,80	2,7	
74,9	-	M6x1	C212	US212	52,50	32,80	2,5	
-	84,2	M6x1	C212	ES212	52,50	32,80	2,4	65
-	84,2	M6x1	C212	EX212	52,50	32,80	3,1	
-	85,0	M6x1	C213	UK213 + H2313	57,20	40,00	3,2	
81,0	-	M6x1	C312	UC312	81,60	51,80	4,7	
-	89,0	M6x1	C312	EX312	81,60	51,80	5,0	
-	85,0	M6x1	C313	UK313 + H2313	93,86	60,50	5,7	70
82,0	-	M6x1	C213	UC213	57,20	40,00	3,2	
-	86,0	M6x1	C213	EX213	57,20	40,00	3,7	
-	98,0	M6x1	C215	UK215 + H2315	66,00	49,50	4,0	
87,5	-	M6x1	C313	UC313	93,86	60,50	5,7	
-	97,0	M6x1	C313	EX313	93,86	60,50	6,1	75
-	98,0	M10x1	C315	UK315 + H2315	113,36	76,80	9,0	
86,5	-	M6x1	C214	UC214	62,00	45,00	5,3	
-	96,8	M6x1	C214	EX214	62,00	45,00	5,8	
-	105,0	M6x1	C216	UK216 + H2316	72,50	54,20	6,8	
94,0	-	M10x1	C314	UC314	104,26	68,00	8,0	75
-	102,0	M10x1	C314	EX314	104,26	68,00	8,5	
-	105,0	M10x1	C316	UK316 + H2316	122,85	86,50	9,8	
91,5	-	M6x1	C215	UC215	66,00	49,50	5,6	
-	102,0	M6x1	C215	EX215	66,00	49,50	6,2	
100,5	-	M10x1	C315	UC315	113,36	76,80	8,3	75
-	113,0	M10x1	C315	EX315	113,36	76,80	9,3	
-	110,0	M10x1	C317	UK317 + H2317	132,60	96,50	11,4	



Gehäuse C200 nachschmierbar
C300 nachschmierbar

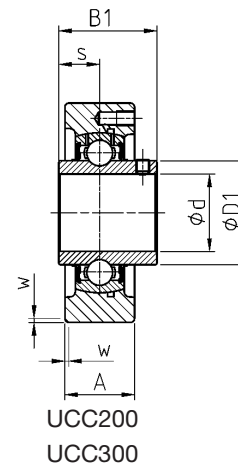
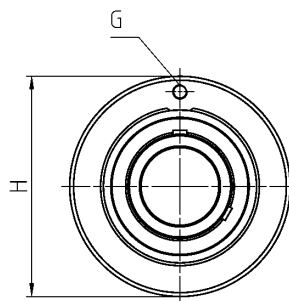
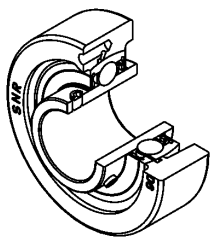

Wellendurchmesser
Einheit

Hauptabmessungen in mm

d [mm]		H h7	A	w	s1	B	B1	s
80	UCC216	170	48	2,0	-	-	82,6	33,3
	EXC216	170	48	2,0	-	-	95,2	37,3
	UCC316	200	60	4,0	-	-	86,0	34,0
	EXC316	200	60	4,0	-	-	106,4	40,5
	UKC318H	225	66	4,0	48,0	86,0	-	-
85	UCC317	215	64	4,0	-	-	96,0	40,0
	EXC317	215	64	4,0	-	-	109,5	42,0
	UKC319H	240	72	4,0	52,0	90,0	-	-
90	UCC318	225	66	4,0	-	-	96,0	40,0
	EXC318	225	66	4,0	-	-	115,9	43,6
	UKC320H	260	75	4,0	54,0	97,0	-	-
95	UCC319	240	72	4,0	-	-	103,0	41,0
	EXC319	240	72	4,0	-	-	122,3	46,8
100	UCC320	260	75	4,0	-	-	108,0	42,0
	EXC320	260	75	4,0	-	-	128,6	50,0
	UKC322H	300	80	5,0	61,0	105,0	-	-
105	UCC321	260	75	4,0	-	-	112,0	44,0
110	UCC322	300	80	5,0	-	-	117,0	46,0
	UKC324H	320	90	5,0	65,0	112,0	-	-
115	UKC326H	340	100	5,0	69,0	121,0	-	-
120	UCC324	320	90	5,0	-	-	126,0	51,0
125	UKC328H	360	100	5,0	73,0	131,0	-	-
130	UCC326	340	100	5,0	-	-	135,0	54,0
140	UCC328	360	100	5,0	-	-	145,0	59,0

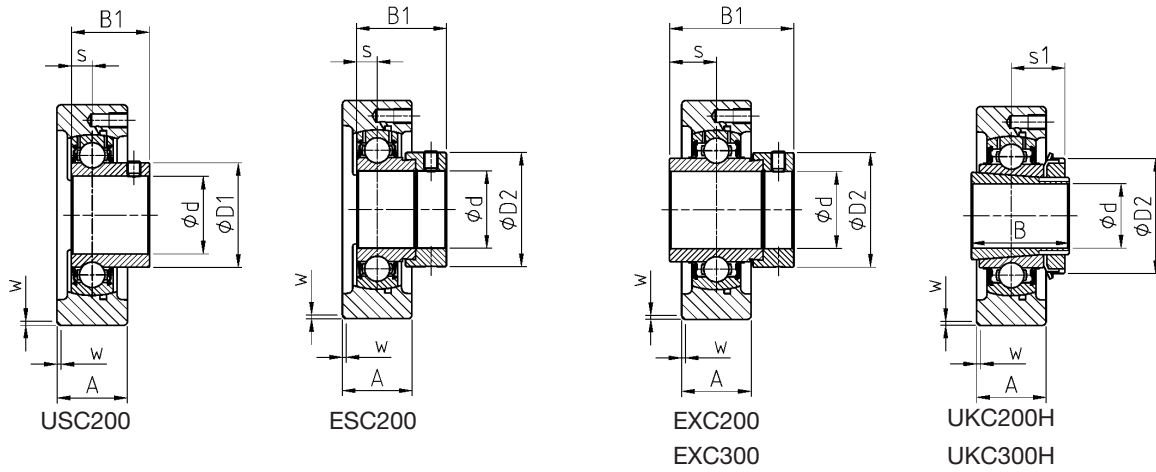

D1	D2	G	Gehäuse	Einsatz	Tragzahl dyn.	Tragzahl stat.	Gewicht	Wellendurchmesser
					C_r [kN]	C_{or} [kN]	[kg]	d [mm]
98,0	-	M6x1	C216	UC216	72,50	54,20	6,4	80
-	110,0	M6x1	C216	EX216	72,50	54,20	6,7	
107,9	-	M10x1	C316	UC316	122,85	86,50	9,6	
-	119,0	M10x1	C316	EX316	122,85	86,50	10,7	
-	120,0	M10x1	C318	UK318 + H2318	143,00	108,00	12,9	
114,0	-	M10x1	C317	UC317	132,60	96,50	11,3	85
-	127,0	M10x1	C317	EX317	132,60	96,50	12,5	
-	125,0	M10x1	C319	UK319 + H2319	156,00	122,00	16,2	
120,0	-	M10x1	C318	UC318	143,00	108,00	12,9	90
-	133,0	M10x1	C318	EX318	143,00	108,00	14,1	
-	130,0	M10x1	C320	UK320 + H2320	171,60	140,00	19,0	
126,5	-	M10x1	C319	UC319	156,00	122,00	15,9	95
-	140,0	M10x1	C319	EX319	156,00	122,00	17,4	
134,5	-	M10x1	C320	UC320	171,60	140,00	19,2	100
-	146,0	M10x1	C320	EX320	171,60	140,00	21,0	
-	145,0	M10x1	C322	UK322 + H2322	205,00	178,00	31,6	
140,5	-	M10x1	C321	UC321	182,00	155,00	20,2	105
149,0	-	M10x1	C322	UC322	205,00	178,00	28,3	110
-	155,0	M10x1	C324	UK324 + H2324	228,00	208,00	36,2	
-	165,0	M10x1	C326	UK326 + H2326	252,00	242,00	43,9	115
163,0	-	M10x1	C324	UC324	228,00	208,00	33,5	120
-	180,0	M10x1	C328	UK328 + H2328	275,00	272,00	51,5	125
177,0	-	M10x1	C326	UC326	252,00	242,00	39,0	130
190,0	-	M10x1	C328	UC328	275,00	272,00	45,5	140

Gehäuse EHE200 nachschmierbar

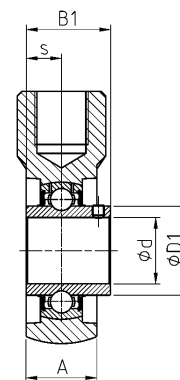
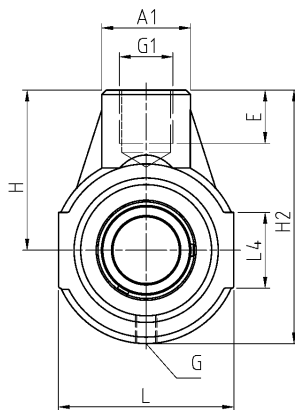
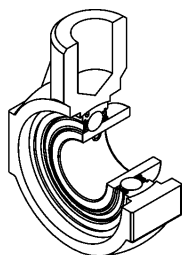

UCEHE200

Wellendurchmesser
Einheit

Hauptabmessungen in mm

d [mm]		H	L -0,5	H2	A	A1	L4	E	G1	s1	B	B1	s
12	UCEHE201	58	65	91	25	30	38	21	M16	-	-	31,0	12,7
	USEHE201	58	65	91	25	30	38	21	M16	-	-	22,0	6,0
	ESEHE201	58	65	91	25	30	38	21	M16	-	-	28,6	6,5
	EXEHE201	58	65	91	25	30	38	21	M16	-	-	43,5	17,0
15	UCEHE202	58	65	91	25	30	38	21	M16	-	-	31,0	12,7
	USEHE202	58	65	91	25	30	38	21	M16	-	-	22,0	6,0
	ESEHE202	58	65	91	25	30	38	21	M16	-	-	28,6	6,5
	EXEHE202	58	65	91	25	30	38	21	M16	-	-	43,5	17,0
17	UCEHE203	58	65	91	25	30	38	21	M16	-	-	31,0	12,7
	USEHE203	58	65	91	25	30	38	21	M16	-	-	22,0	6,0
	ESEHE203	58	65	91	25	30	38	21	M16	-	-	28,6	6,5
	EXEHE203	58	65	91	25	30	38	21	M16	-	-	43,5	17,0
20	UCEHE204	58	65	91	25	30	38	21	M16	-	-	31,0	12,7
	USEHE204	58	65	91	25	30	38	21	M16	-	-	25,0	7,0
	ESEHE204	58	65	91	25	30	38	21	M16	-	-	30,9	7,5
	EXEHE204	58	65	91	25	30	38	21	M16	-	-	43,5	17,0
	UKEHE205H	64	70	99	28	35	38	22	M20	18,5	35,0	-	-
25	UCEHE205	64	70	99	28	35	38	22	M20	-	-	34,0	14,3
	USEHE205	64	70	99	28	35	38	22	M20	-	-	27,0	7,5
	ESEHE205	64	70	99	28	35	38	22	M20	-	-	30,9	7,5
	EXEHE205	64	70	99	28	35	38	22	M20	-	-	44,3	17,4
	UKEHE206H	72	85	114	32	40	40	24	M24	20,5	38,0	-	-
30	UCEHE206	72	85	114	32	40	40	24	M24	-	-	38,1	15,9
	USEHE206	72	85	114	32	40	40	24	M24	-	-	30,0	8,0
	ESEHE206	72	85	114	32	40	40	24	M24	-	-	35,7	9,0
	EXEHE206	72	85	114	32	40	40	24	M24	-	-	48,3	18,2
	UKEHE207H	76	90	122	32	40	40	24	M24	22,5	43,0	-	-
35	UCEHE207	76	90	122	32	40	40	24	M24	-	-	42,9	17,5
	USEHE207	76	90	122	32	40	40	24	M24	-	-	32,0	8,5
	ESEHE207	76	90	122	32	40	40	24	M24	-	-	38,9	9,5
	EXEHE207	76	90	122	32	40	40	24	M24	-	-	51,1	18,8
	UKEHE208H	85	100	135	36	40	45	24	M24	24,5	46,0	-	-
40	UCEHE208	85	100	135	36	40	45	24	M24	-	-	49,2	19,0
	USEHE208	85	100	135	36	40	45	24	M24	-	-	34,0	9,0
	ESEHE208	85	100	135	36	40	45	24	M24	-	-	43,7	11,0
	EXEHE208	85	100	135	36	40	45	24	M24	-	-	56,3	21,4
	UKEHE209H	90	110	145	40	40	45	24	M24	26,0	50,0	-	-

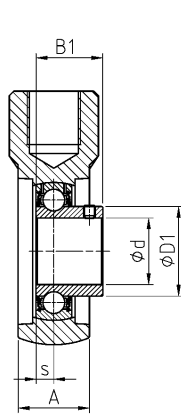

USEHE200

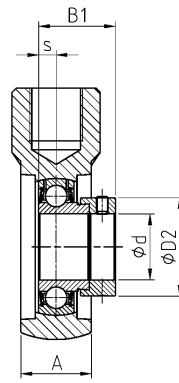

ESEHE200

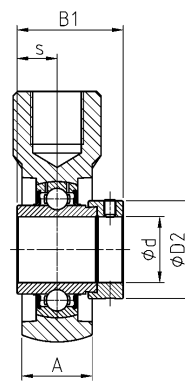

EXEHE200

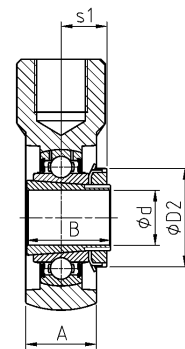

UKEHE200H

D1	D2	G	Gehäuse	Einsatz	Tragzahl dyn.	Tragzahl stat.	Gewicht	Wellendurchmesser
D1	D2	G			C_r [kN]	C_{or} [kN]	[kg]	d [mm]
29,0	-	R1/8"	EHE204	UC201	12,80	6,65	0,8	12
24,6	-	M6x1	EHE203	US201	9,55	4,78	0,4	12
-	28,6	M6x1	EHE203	ES201	9,55	4,78	0,5	
-	33,3	R1/8"	EHE204	EX201	12,80	6,65	0,8	
29,0	-	R1/8"	EHE204	UC202	12,80	6,65	0,8	
24,6	-	M6x1	EHE203	US202	9,55	4,78	0,4	
-	28,6	M6x1	EHE203	ES202	9,55	4,78	0,5	
-	33,3	R1/8"	EHE204	EX202	12,80	6,65	0,8	
29,0	-	R1/8"	EHE204	UC203	12,80	6,65	0,5	17
24,6	-	M6x1	EHE203	US203	9,55	4,78	0,5	
-	28,6	M6x1	EHE203	ES203	9,55	4,78	0,5	
-	33,3	R1/8"	EHE204	EX203	12,80	6,65	0,8	
29,0	-	R1/8"	EHE204	UC204	12,80	6,65	0,7	20
29,0	-	R1/8"	EHE204	US204	12,80	6,65	0,7	
-	33,3	R1/8"	EHE204	ES204	12,80	6,65	0,7	
-	33,3	R1/8"	EHE204	EX204	12,80	6,65	0,8	
-	38,0	R1/8"	EHE205	UK205 + H2305	14,00	7,88	1,2	
34,0	-	R1/8"	EHE205	UC205	14,00	7,88	1,2	25
34,0	-	R1/8"	EHE205	US205	14,00	7,88	1,1	
-	38,1	R1/8"	EHE205	ES205	14,00	7,88	1,1	
-	38,1	R1/8"	EHE205	EX205	14,00	7,88	1,2	
-	45,0	R1/8"	EHE206	UK206 + H2306	19,50	11,20	1,4	
40,3	-	R1/8"	EHE206	UC206	19,50	11,20	1,3	30
40,3	-	R1/8"	EHE206	US206	19,50	11,20	1,3	
-	44,5	R1/8"	EHE206	ES206	19,50	11,20	1,3	
-	44,5	R1/8"	EHE206	EX206	19,50	11,20	1,4	
-	52,0	R1/8"	EHE207	UK207 + H2307	25,70	15,20	1,6	
48,0	-	R1/8"	EHE207	UC207	25,70	15,20	1,6	
48,0	-	R1/8"	EHE207	US207	25,70	15,20	1,5	
-	55,6	R1/8"	EHE207	ES207	25,70	15,20	1,6	
-	55,6	R1/8"	EHE207	EX207	25,70	15,20	1,7	
-	58,0	R1/8"	EHE208	UK208 + H2308	29,60	18,20	1,9	
53,0	-	R1/8"	EHE208	UC208	29,60	18,20	1,8	40
53,0	-	R1/8"	EHE208	US208	29,60	18,20	1,8	
-	60,3	R1/8"	EHE208	ES208	29,60	18,20	1,9	
-	60,3	R1/8"	EHE208	EX208	29,60	18,20	2,0	
-	65,0	R1/8"	EHE209	UK209 + H2309	31,85	20,80	2,0	

Gehäuse EHE200 nachschmierbar

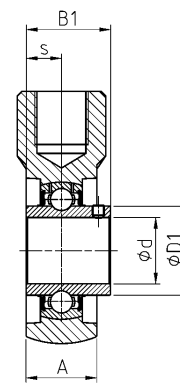
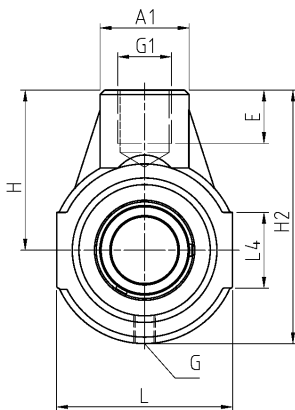
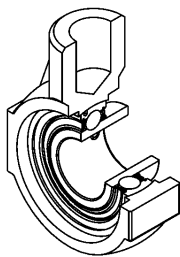

UCEHE200

Wellendurchmesser
Einheit

Hauptabmessungen in mm

d [mm]		H	L -0,5	H2	A	A1	L4	E	G1	s1	B	B1	s
45	UCEHE209	90	110	145	40	40	45	24	M24	-	-	49,2	19,0
	USEHE209	90	110	145	40	40	45	24	M24	-	-	41,2	10,2
	ESEHE209	90	110	145	40	40	45	24	M24	-	-	43,7	11,0
	EXEHE209	90	110	145	40	40	45	24	M24	-	-	56,3	21,4
	UKEHE210H	90	110	145	40	40	46	24	M24	27,5	55,0	-	-
50	UCEHE210	90	110	145	40	40	46	24	M24	-	-	51,6	19,0
	USEHE210	90	110	145	40	40	46	24	M24	-	-	43,5	10,9
	ESEHE210	90	110	145	40	40	46	24	M24	-	-	43,7	11,0
	EXEHE210	90	110	145	40	40	46	24	M24	-	-	62,7	24,6

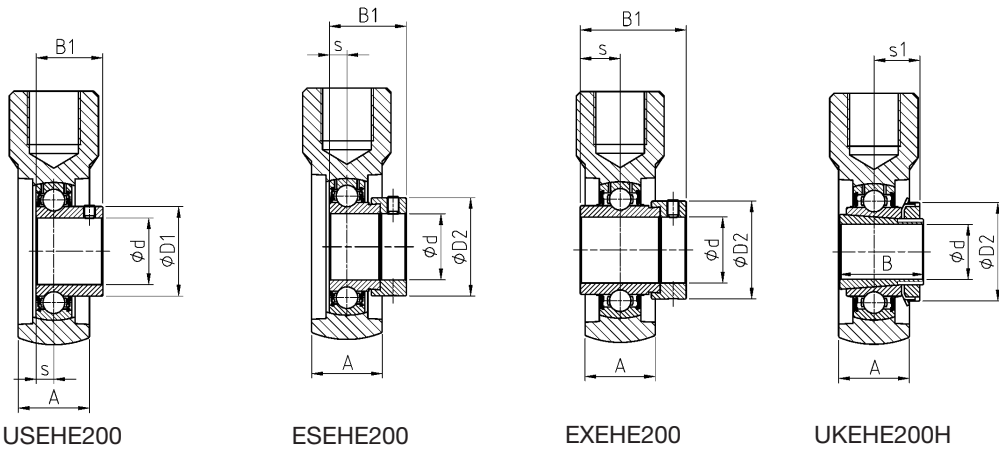

D1	D2	G	Gehäuse	Einsatz	Tragzahl dyn.	Tragzahl stat.	Gewicht	Wellendurchmesser
					C_r [kN]	C_{Or} [kN]	[kg]	d [mm]
57,2	-	R1/8"	EHE209	UC209	31,85	20,80	1,9	45
57,2	-	R1/8"	EHE209	US209	31,85	20,80	1,9	
-	63,5	R1/8"	EHE209	ES209	31,85	20,80	1,9	
-	63,5	R1/8"	EHE209	EX209	31,85	20,80	2,1	
-	70,0	R1/8"	EHE210	UK210 + H2310	35,10	23,20	2,2	
61,8	-	R1/8"	EHE210	UC210	35,10	23,20	2,0	50
61,8	-	R1/8"	EHE210	US210	35,10	23,20	2,0	
-	69,9	R1/8"	EHE210	ES210	35,10	23,20	2,0	
-	69,9	R1/8"	EHE210	EX210	35,10	23,20	2,2	

Gehäuse PP200

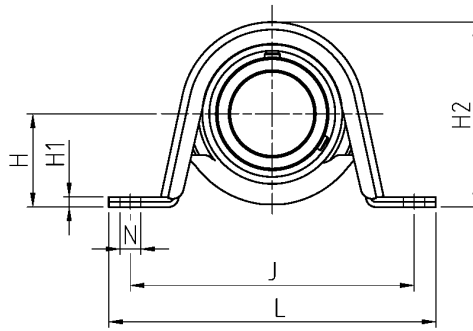
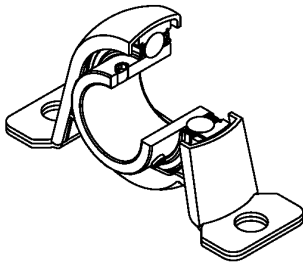

Wellendurchmesser
Einheit

Hauptabmessungen in mm

d [mm]		L	H	H1	H2	A	A1	J	N	B1	s
12	USPP201	85,7	22,2	2,4	43,2	25,4	15,9	68	9	22,0	6,0
	ESPP201	85,7	22,2	2,4	43,2	25,4	15,9	68	9	28,6	6,5
15	USPP202	85,7	22,2	2,4	43,2	25,4	15,9	68	9	22,0	6,0
	ESPP202	85,7	22,2	2,4	43,2	25,4	15,9	68	9	28,6	6,5
17	USPP203	85,7	22,2	2,4	43,2	25,4	15,9	68	9	22,0	6,0
	ESPP203	85,7	22,2	2,4	43,2	25,4	15,9	68	9	28,6	6,5
20	USPP204	98,4	25,4	2,4	49,9	31,7	21,6	76	9	25,0	7,0
	ESPP204	98,4	25,4	2,4	49,9	31,7	21,6	76	9	30,9	7,5
25	USPP205	108,0	28,6	2,8	55,8	31,7	21,6	86	11	27,0	7,5
	ESPP205	108,0	28,6	2,8	55,8	31,7	21,6	86	11	30,9	7,5
30	USPP206	117,5	33,3	3,6	65,7	37,5	25,5	95	11	30,0	8,0
	ESPP206	117,5	33,3	3,6	65,7	37,5	25,5	95	11	35,7	9,0
35	USPP207	128,6	39,7	4,4	77,5	41,0	28,4	106	11	32,0	8,5
	ESPP207	128,6	39,7	4,4	77,5	41,0	28,4	106	11	38,9	9,5

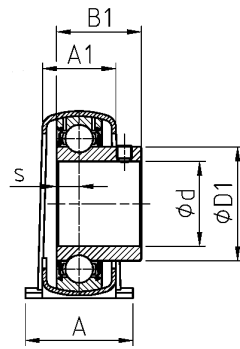

USPP200

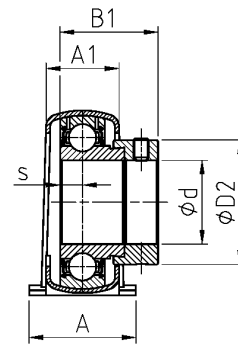

ESPP200

		Gehäuse	Einsatz	Tragzahl dyn.	Tragzahl stat.	Gewicht	Wellendurch- messer
D1	D2			C_r [kN]	C_{0r} [kN]	[kg]	d [mm]
24,6	-	PP203	US201	9,55	4,78	0,2	12
-	28,6	PP203	ES201	9,55	4,78	0,2	
24,6	-	PP203	US202	9,55	4,78	0,2	15
-	28,6	PP203	ES202	9,55	4,78	0,2	
24,6	-	PP203	US203	9,55	4,78	0,2	17
-	28,6	PP203	ES203	9,55	4,78	0,2	
29,0	-	PP204	US204	12,80	6,65	0,2	20
-	33,3	PP204	ES204	12,80	6,65	0,3	
34,0	-	PP205	US205	14,00	7,88	0,4	25
-	38,1	PP205	ES205	14,00	7,88	0,4	
40,3	-	PP206	US206	19,50	11,20	0,6	30
-	44,5	PP206	ES206	19,50	11,20	0,6	
48,0	-	PP207	US207	25,70	15,20	0,9	35
-	55,6	PP207	ES207	25,70	15,20	1,0	

Gehäuse PF200

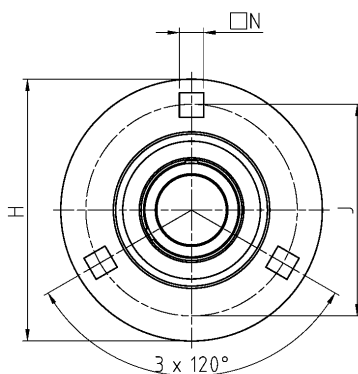
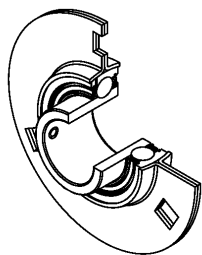

PF203...207

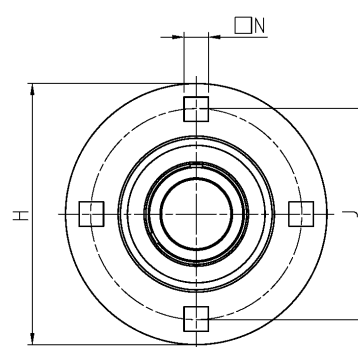

PF208...212

Wellendurchmesser
Einheit

Hauptabmessungen in mm

d [mm]		H	J	J2	A	A1	N	B1	s
12	USPF201	81,0	63,5	49,0	6,7	4,0	7,1	22,0	6,0
	ESPF201	81,0	63,5	49,0	6,7	4,0	7,1	28,6	6,5
15	USPF202	81,0	63,5	49,0	6,7	4,0	7,1	22,0	6,0
	ESPF202	81,0	63,5	49,0	6,7	4,0	7,1	28,6	6,5
17	USPF203	81,0	63,5	49,0	6,7	4,0	7,1	22,0	6,0
	ESPF203	81,0	63,5	49,0	6,7	4,0	7,1	28,6	6,5
20	USPF204	90,5	71,5	55,0	7,7	4,0	8,7	25,0	7,0
	ESPF204	90,5	71,5	55,0	7,7	4,0	8,7	30,9	7,5
25	USPF205	95,2	76,0	60,0	8,7	4,0	8,7	27,0	7,5
	ESPF205	95,2	76,0	60,0	8,7	4,0	8,7	30,9	7,5
30	USPF206	112,7	90,5	71,0	9,0	5,0	10,5	30,0	8,0
	ESPF206	112,7	90,5	71,0	9,0	5,0	10,5	35,7	9,0
35	USPF207	122,2	100,0	81,0	10,0	5,0	10,5	32,0	8,5
	ESPF207	122,2	100,0	81,0	10,0	5,0	10,5	38,9	9,5
40	USPF208	147,8	119,0	91,0	10,0	7,0	13,5	34,0	9,0
	ESPF208	147,8	119,0	91,0	10,0	7,0	13,5	43,7	11,0
45	USPF209	149,2	120,5	97,0	10,0	7,0	13,5	41,2	10,2
	ESPF209	149,2	120,5	97,0	10,0	7,0	13,5	43,7	11,0
50	USPF210	155,6	127,0	102,0	10,5	8,0	13,5	43,5	10,9
	ESPF210	155,6	127,0	102,0	10,5	8,0	13,5	43,7	11,0
55	USPF211	166,6	138,0	113,0	10,7	8,0	13,5	45,3	11,8
	ESPF211	166,6	138,0	113,0	10,7	8,0	13,5	48,4	12,0
60	USPF212	176,2	147,6	122,0	11,9	8,0	13,5	53,7	14,9
	ESPF212	176,2	147,6	122,0	11,9	8,0	13,5	49,3	12,0

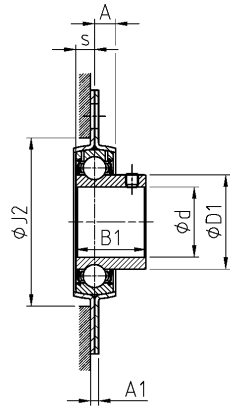

USPF200

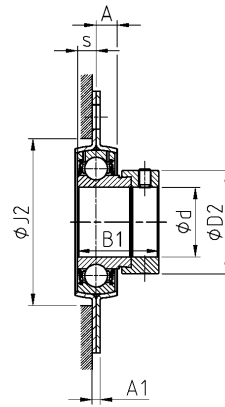

ESPF200

		Gehäuse	Einsatz	Tragzahl dyn.	Tragzahl stat.	Gewicht	Wellendurch- messer
D1	D2			C_r [kN]	C_{Or} [kN]	[kg]	d [mm]
24,6	-	PF203	US201	9,55	4,78	0,2	12
-	28,6	PF203	ES201	9,55	4,78	0,2	
24,6	-	PF203	US202	9,55	4,78	0,2	15
-	28,6	PF203	ES202	9,55	4,78	0,2	
24,6	-	PF203	US203	9,55	4,78	0,2	17
-	28,6	PF203	ES203	9,55	4,78	0,2	
29,0	-	PF204	US204	12,80	6,65	0,3	20
-	33,3	PF204	ES204	12,80	6,65	0,3	
34,0	-	PF205	US205	14,00	7,88	0,4	25
-	38,1	PF205	ES205	14,00	7,88	0,4	
40,3	-	PF206	US206	19,50	11,20	0,7	30
-	44,5	PF206	ES206	19,50	11,20	0,7	
48,0	-	PF207	US207	25,70	15,20	0,9	35
-	55,6	PF207	ES207	25,70	15,20	1,0	
53,0	-	PF208	US208	29,60	18,20	1,5	40
-	60,3	PF208	ES208	29,60	18,20	1,6	
57,2	-	PF209	US209	31,85	20,80	1,7	45
-	63,5	PF209	ES209	31,85	20,80	1,7	
61,8	-	PF210	US210	35,10	23,20	1,8	50
-	69,9	PF210	ES210	35,10	23,20	1,8	
69,0	-	PF211	US211	43,55	29,20	2,2	55
-	76,2	PF211	ES211	43,55	29,20	2,0	
74,9	-	PF212	US212	52,50	32,80	2,4	60
-	84,2	PF212	ES212	52,50	32,80	2,3	

Gehäuse PFL200

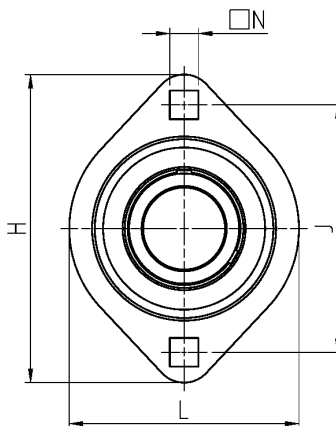
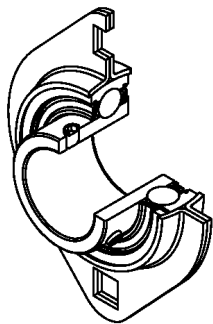

Wellendurchmesser
Einheit

Hauptabmessungen in mm

d [mm]		L	H	J	J2	A	A1	N	B1
12	USPFL201	58,7	81,0	63,5	49,0	6,7	4,0	7,1	22,0
	ESPFL201	58,7	81,0	63,5	49,0	6,7	4,0	7,1	28,6
15	USPFL202	58,7	81,0	63,5	49,0	6,7	4,0	7,1	22,0
	ESPFL202	58,7	81,0	63,5	49,0	6,7	4,0	7,1	28,6
17	USPFL203	58,7	81,0	63,5	49,0	6,7	4,0	7,1	22,0
	ESPFL203	58,7	81,0	63,5	49,0	6,7	4,0	7,1	28,6
20	USPFL204	66,7	90,5	71,5	55,0	7,7	4,0	8,7	25,0
	ESPFL204	66,7	90,5	71,5	55,0	7,7	4,0	8,7	30,9
25	USPFL205	71,0	95,2	76,2	60,0	8,7	4,0	8,7	27,0
	ESPFL205	71,0	95,2	76,2	60,0	8,7	4,0	8,7	30,9
30	USPFL206	84,0	112,7	90,5	71,0	9,0	5,0	10,5	30,0
	ESPFL206	84,0	112,7	90,5	71,0	9,0	5,0	10,5	35,7
35	USPFL207	93,7	123,0	100,0	81,0	10,5	5,0	10,5	32,0
	ESPFL207	93,7	123,0	100,0	81,0	10,5	5,0	10,5	38,9
40	USPFL208	100,0	151,0	119,0	91,0	11,5	7,0	13,5	34,0
	ESPFL208	100,0	151,0	119,0	91,0	11,5	7,0	13,5	43,7

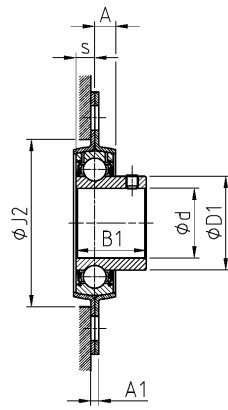

USPFL200

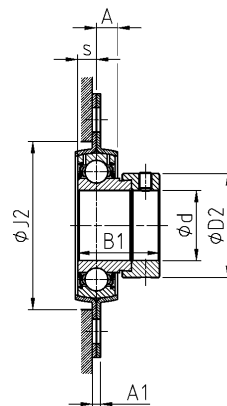

ESPFL200

s	D1	D2	Gehäuse	Einsatz	Tragzahl dyn.	Tragzahl stat.	Gewicht	Wellendurch- messer
			PFL203	US201	C_r [kN]	C_{0r} [kN]	[kg]	d [mm]
6,0	24,6	-	PFL203	US201	9,55	4,78	0,2	12
6,5	-	28,6	PFL203	ES201	9,55	4,78	0,2	12
6,0	24,6	-	PFL203	US202	9,55	4,78	0,2	15
6,5	-	28,6	PFL203	ES202	9,55	4,78	0,2	15
6,0	24,6	-	PFL203	US203	9,55	4,78	0,2	17
6,5	-	28,6	PFL203	ES203	9,55	4,78	0,2	17
7,0	29,0	-	PFL204	US204	12,80	6,65	0,2	20
7,5	-	33,3	PFL204	ES204	12,80	6,65	0,3	20
7,5	34,0	-	PFL205	US205	14,00	7,88	0,4	25
7,5	-	38,1	PFL205	ES205	14,00	7,88	0,4	25
8,0	40,3	-	PFL206	US206	19,50	11,20	0,6	30
9,0	-	44,5	PFL206	ES206	19,50	11,20	0,6	30
8,5	48,0	-	PFL207	US207	25,70	15,20	0,9	35
9,5	-	55,6	PFL207	ES207	25,70	15,20	1,0	35
9,0	53,0	-	PFL208	US208	29,60	18,20	1,1	40
11,0	-	60,3	PFL208	ES208	29,60	18,20	1,2	40

Gehäuse PFT200

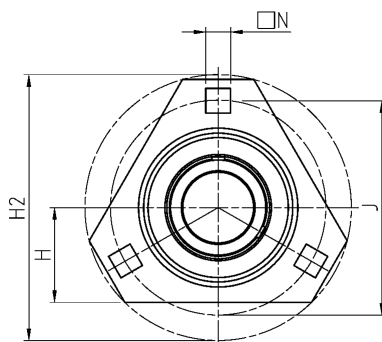
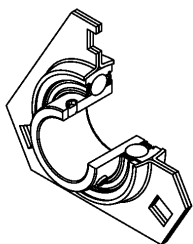

Wellendurchmesser		Einheit		Hauptabmessungen in mm						
d [mm]		H	H2	J	J2	A	A1	N	B1	
20	USPFT204	33,3	90,5	71,5	55,0	7,2	4,0	8,7	25,0	
	ESPFT204	33,3	90,5	71,5	55,0	7,2	4,0	8,7	30,9	
25	USPFT205	34,2	95,2	76,0	60,0	8,7	4,0	8,7	27,0	
	ESPFT205	34,2	95,2	76,0	60,0	8,7	4,0	8,7	30,9	
30	USPFT206	40,2	112,7	90,5	71,0	10,5	5,0	10,5	30,0	
	ESPFT206	40,2	112,7	90,5	71,0	10,5	5,0	10,5	35,7	
35	USPFT207	44,2	122,2	100,0	81,0	10,5	5,0	10,5	32,0	
	ESPFT207	44,2	122,2	100,0	81,0	10,5	5,0	10,5	38,9	

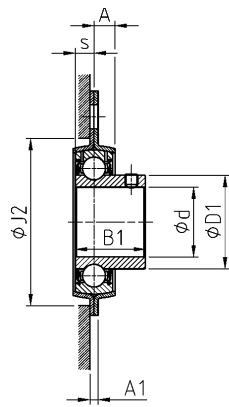

USPFT200

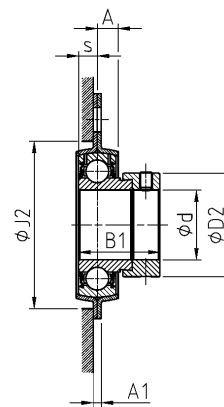

ESPFT200

s	D1	D2	Gehäuse	Einsatz	Tragzahl dyn.	Tragzahl stat.	Gewicht	Wellendurch- messer
			PFT	US	C_r [kN]	C_{or} [kN]	[kg]	d [mm]
7,0	29,0	-	PFT204	US204	12,80	6,65	0,2	20
7,5	-	33,3	PFT204	ES204	12,80	6,65	0,3	
7,5	34,0	-	PFT205	US205	14,00	7,88	0,4	25
7,5	-	38,1	PFT205	ES205	14,00	7,88	0,4	
8,0	40,3	-	PFT206	US206	19,50	11,20	0,6	30
9,0	-	44,5	PFT206	ES206	19,50	11,20	0,6	
8,5	48,0	-	PFT207	US207	25,70	15,20	0,9	35
9,5	-	55,6	PFT207	ES207	25,70	15,20	1,0	

Gehäuse PFE200

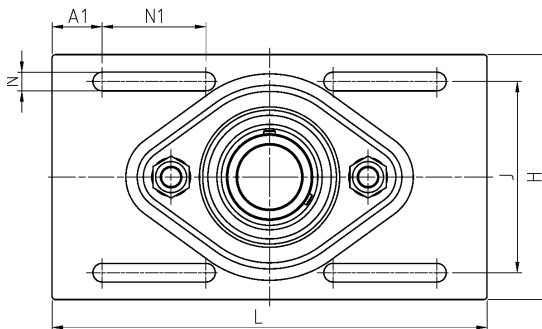
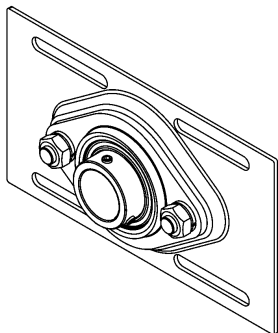

Wellendurchmesser
Einheit

Hauptabmessungen in mm

d [mm]		L	H	J	A	A1	A2	e	N	N1	T	B1	s
25	USPFE205	203,2	104,8	80,2	19,0	23,4	29,8	10,3	8,7	48,5	2,0	27,0	7,5
	ESPFE205	203,2	104,8	80,2	19,0	23,4	33,7	10,3	8,7	48,5	2,0	30,9	7,5
30	USPFE206	203,2	114,3	89,2	21,1	23,4	34,1	12,1	8,7	48,5	2,5	30,0	8,0
	ESPFE206	203,2	114,3	89,2	21,1	23,4	38,8	12,1	8,7	48,5	2,5	35,7	9,0

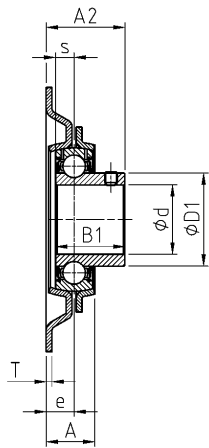

USPFE200

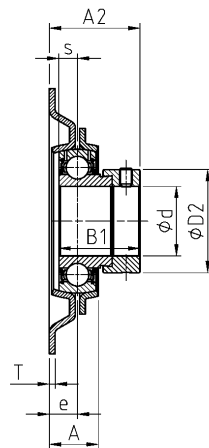

ESPFE200

		Gehäuse	Einsatz	Tragzahl dyn.	Tragzahl stat.	Gewicht	Wellendurch- messer
D1	D2			C _r [kN]	C _{0r} [kN]	[kg]	d [mm]
34,0	-	PFE205	US205	14,00	7,88	0,6	25
-	38,1	PFE205	ES205	14,00	7,88	0,6	
40,3	-	PFE206	US206	19,50	11,20	0,8	30
-	44,5	PFE206	ES206	19,50	11,20	0,9	

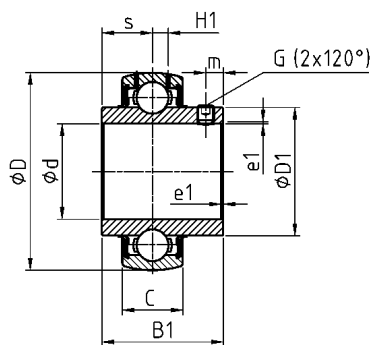
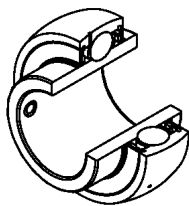
Einsatz mit Gewindestiften UC200 nachschmierbar

Wellendurchmesser Einsatz		Hauptabmessungen in mm										Tragzahl dyn.	Tragzahl stat.	Gewicht	Wellendurchmesser
d [mm]		D	C	B1	s _{max}	D1	H1	m	G	a*	e1	C _r [kN]	C _{0r} [kN]	[kg]	d [mm]
12	UC201	47,0	16,0	31,0	12,7	29,0	4,4	4,7	M6x1	3,0	0,6	12,80	6,65	0,21	12
15	UC202	47,0	16,0	31,0	12,7	29,0	4,4	4,7	M6x1	3,0	0,6	12,80	6,65	0,20	15
17	UC203	47,0	16,0	31,0	12,7	29,0	4,4	4,7	M6x1	3,0	0,6	12,80	6,65	0,18	17
20	UC204	47,0	16,0	31,0	12,7	29,0	4,4	4,7	M6x1	3,0	0,6	12,80	6,65	0,17	20
25	UC205	52,0	17,0	34,0	14,3	34,0	4,3	5,5	M6x1	3,0	0,6	14,00	7,88	0,21	25
30	UC206	62,0	19,0	38,1	15,9	40,3	5,0	5,5	M6x1	3,0	0,6	19,50	11,20	0,32	30
35	UC207	72,0	20,0	42,9	17,5	48,0	5,8	6,5	M8x1	4,0	1,1	25,70	15,20	0,47	35
40	UC208	80,0	21,0	49,2	19,0	53,0	6,3	8,0	M8x1	4,0	1,1	29,60	18,20	0,64	40
45	UC209	85,0	22,0	49,2	19,0	57,2	6,8	8,0	M8x1	4,0	1,1	31,85	20,80	0,68	45
50	UC210	90,0	23,0	51,6	19,0	61,8	6,5	9,0	M10x1,25	5,0	1,1	35,10	23,20	0,80	50
55	UC211	100,0	25,0	55,6	22,2	69,0	7,2	9,0	M10x1,25	5,0	1,1	43,55	29,20	1,12	55
60	UC212	110,0	27,0	65,1	25,4	74,9	8,2	10,5	M10x1,25	5,0	1,1	52,50	32,80	1,53	60
65	UC213	120,0	28,0	65,1	25,4	82,0	8,0	12,0	M12x1,25	6,0	1,5	57,20	40,00	1,86	65
70	UC214	125,0	30,0	74,6	30,2	86,5	9,0	12,0	M12x1,25	6,0	2,0	62,00	45,00	2,05	70
75	UC215	130,0	30,0	77,8	33,3	91,5	9,0	12,0	M12x1,25	6,0	2,0	66,00	49,50	2,21	75
80	UC216	140,0	33,0	82,6	33,3	98,0	10,3	14,0	M12x1,25	6,0	2,0	72,50	54,20	2,79	80
85	UC217	150,0	35,0	85,7	34,1	105,1	11,0	14,0	M12x1,25	6,0	2,0	83,20	63,80	3,38	85
90	UC218	160,0	37,0	96,0	39,7	111,0	12,0	14,0	M12x1,25	6,0	2,0	96,00	71,50	4,45	90

* SW Innensechskant

Einsatz

Einsatz mit Gewindestift

US200 nachschmierbar

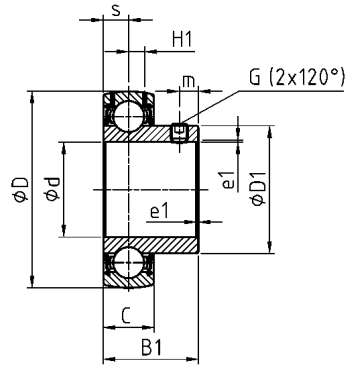
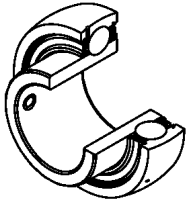

Wellendurchmesser		Hauptabmessungen in mm										Tragzahl dyn.		Tragzahl stat.		Gewicht		Wellendurchmesser	
d	Einsatz	D	C	B1	s_{max}	D1	H1	m	G	a^*	e1	C_r	C_{0r}	[kg]	d				
[mm]												[kN]	[kN]		[mm]				
12	US201	40,0	12,0	22,0	6,0	24,6	3,6	4,0	M5x0,8	2,5	0,6	9,55	4,78	0,09	12				
15	US202	40,0	12,0	22,0	6,0	24,6	3,6	4,0	M5x0,8	2,5	0,6	9,55	4,78	0,08	15				
17	US203	40,0	12,0	22,0	6,0	24,6	3,6	4,0	M5x0,8	2,5	0,6	9,55	4,78	0,10	17				
20	US204	47,0	14,0	25,0	7,0	29,0	4,0	5,0	M6x1	3,0	0,6	12,80	6,65	0,13	20				
25	US205	52,0	15,0	27,0	7,5	34,0	4,3	5,5	M6x1	3,0	0,6	14,00	7,88	0,17	25				
30	US206	62,0	16,0	30,0	8,0	40,3	5,0	6,0	M6x1	3,0	0,6	19,50	11,20	0,27	30				
35	US207	72,0	17,0	32,0	8,5	48,0	5,7	6,5	M6x1	3,0	0,6	25,70	15,20	0,42	35				
40	US208	80,0	18,0	34,0	9,0	53,0	6,2	7,0	M8x1	4,0	1,1	29,60	18,20	0,60	40				
45	US209	85,0	19,0	41,2	10,2	57,2	6,5	8,2	M8x1	4,0	1,1	31,85	20,80	0,65	45				
50	US210	90,0	20,0	43,5	10,9	61,8	6,5	9,2	M8x1	4,0	1,1	35,10	23,20	0,76	50				
55	US211	100,0	23,0	45,3	11,8	69,0	7,2	9,8	M10x1,25	5,0	1,1	43,55	29,20	1,07	55				
60	US212	110,0	24,0	53,7	14,9	74,9	8,0	9,8	M10x1,25	5,0	1,1	52,50	32,80	1,30	60				

* SW Innensechskant

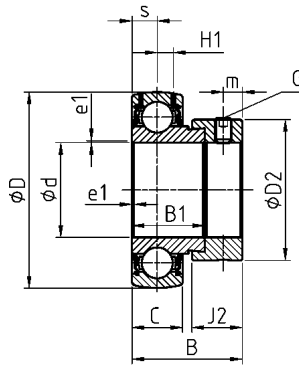
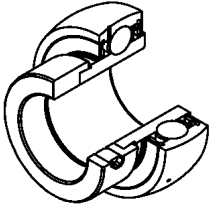

Wellendurchmesser [mm]	Einsatz ...G2	Hauptabmessungen in mm											Tragzahl dyn. [kN]	Tragzahl stat. [kN]	Gewicht [kg]	Wellendurchmesser [mm]	
		D	C	B1	J2	B	s_{max}	D2	H1	m	G	a^*					e1
12	ES201	40	12	19,1	13,5	28,6	6,5	28,6	3,6	5,0	M6x1	3	0,6	9,55	4,78	0,14	12
15	ES202	40	12	19,1	13,5	28,6	6,5	28,6	3,6	5,0	M6x1	3	0,6	9,55	4,78	0,13	15
17	ES203	40	12	19,1	13,5	28,6	6,5	28,6	3,6	5,0	M6x1	3	0,6	9,55	4,78	0,13	17
20	ES204	47	14	21,4	13,5	30,9	7,5	33,3	4,0	5,0	M6x1	3	0,6	12,80	6,65	0,15	20
25	ES205	52	15	21,4	13,5	30,9	7,5	38,1	4,3	5,0	M6x1	3	0,6	14,00	7,88	0,19	25
30	ES206	62	16	23,8	15,9	35,7	9,0	44,5	5,0	6,0	M8x1	3	0,6	19,50	11,20	0,33	30
35	ES207	72	17	25,4	17,5	38,9	9,5	55,6	5,7	6,5	M8x1	4	1,1	25,70	15,20	0,50	35
40	ES208	80	18	30,2	18,3	43,7	11,0	60,3	6,2	6,5	M8x1	4	1,1	29,60	18,20	0,65	40
45	ES209	85	19	30,2	18,3	43,7	11,0	63,5	6,5	6,5	M8x1	4	1,1	31,85	20,80	0,69	45
50	ES210	90	20	30,2	18,3	43,7	11,0	69,9	6,5	6,5	M8x1	4	1,1	35,10	23,20	0,80	50
55	ES211	100	24	32,5	20,7	48,4	12,0	76,2	7,2	8,0	M10x1,25	5	1,1	43,55	29,20	0,87	55
60	ES212	110	24	33,4	22,3	49,3	12,0	84,2	8,0	8,0	M10x1,25	5	1,1	52,50	32,80	1,20	60

* SW Innensechskant

Einsatz

Einsatz mit Excenterring

EX200 nachschmierbar

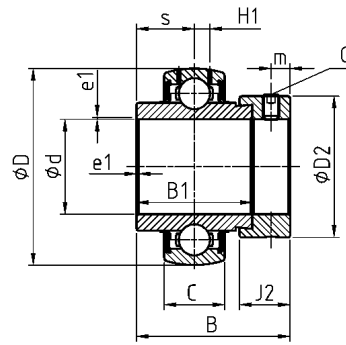
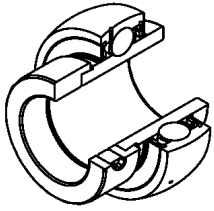

Hauptabmessungen in mm

d [mm]	...G2	D	C	B1	J2	B	s _{max}	D2	H1	m	G	a*	e1	Tragzahl			d
														C _r [kN]	C _{or} [kN]	[kg]	
12	EX201	47	16	34,0	13,5	43,5	17,0	33,3	4,4	5,0	M6x1	3	0,6	12,80	6,65	0,29	12
15	EX202	47	16	34,0	13,5	43,5	17,0	33,3	4,4	5,0	M6x1	3	0,6	12,80	6,65	0,27	15
17	EX203	47	16	34,0	13,5	43,5	17,0	33,3	4,4	5,0	M6x1	3	0,6	12,80	6,65	0,25	17
20	EX204	47	16	34,0	13,5	43,5	17,0	33,3	4,4	5,0	M6x1	3	0,6	12,80	6,65	0,22	20
25	EX205	52	17	34,8	13,5	44,3	17,4	38,1	4,3	5,0	M6x1	3	0,6	14,00	7,88	0,25	25
30	EX206	62	19	36,4	15,9	48,3	18,2	44,5	5,0	6,0	M6x1	3	0,6	19,50	11,20	0,41	30
35	EX207	72	20	37,6	17,5	51,1	18,8	55,6	5,8	6,5	M8x1	4	1,1	25,70	15,20	0,60	35
40	EX208	80	21	42,8	18,3	56,3	21,4	60,3	6,3	6,5	M8x1	4	1,1	29,60	18,20	0,78	40
45	EX209	85	22	42,8	18,3	56,3	21,4	63,5	6,8	6,5	M8x1	4	1,1	31,85	20,80	0,87	45
50	EX210	90	23	49,2	18,3	62,7	24,6	69,9	6,5	6,5	M8x1	4	1,1	35,10	23,20	1,01	50
55	EX211	100	25	55,4	20,7	71,3	27,7	76,2	7,2	8,0	M10x1,25	5	1,5	43,55	29,20	1,39	55
60	EX212	110	27	61,8	22,3	77,7	30,9	84,2	8,2	8,0	M10x1,25	5	1,5	52,50	32,80	1,87	60
65	EX213	120	28	68,2	23,5	85,7	34,1	86,0	8,0	8,5	M10x1,25	5	1,5	57,20	40,00	2,41	65
70	EX214	125	30	68,2	23,5	85,7	34,1	96,8	9,0	8,5	M10x1,25	5	2,0	62,00	45,00	2,57	70
75	EX215	130	30	74,6	23,9	92,1	37,3	102,0	9,0	8,5	M10x1,25	5	2,0	66,00	49,50	2,84	75
80	EX216	140	33	74,6	27,0	95,2	37,3	110,0	10,3	10,3	M12x1,25	6	2,0	72,50	54,20	3,12	80
85	EX217	150	35	53,2	27,0	73,2	23,4	119,0	11,0	10,0	M12x1,25	6	2,0	83,20	63,80	3,72	85
90	EX218	160	37	55,0	24,0	72,5	24,5	120,0	12,0	9,5	M12x1,25	6	2,0	96,00	71,50	4,90	90

* SW Innensechskant

Einsatz mit Spannhülse
UK200+H nachschmierbar

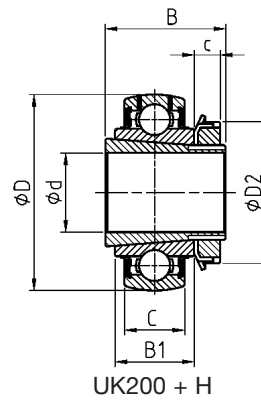
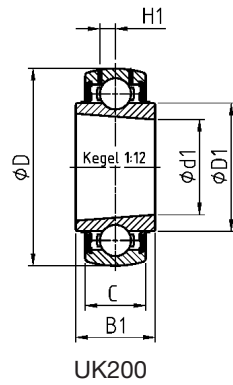
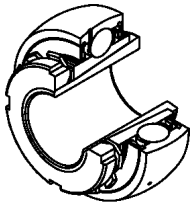

Hauptabmessungen in mm																	
Wellendurchmesser		Einsatz + Spannhülse		Einsatz		Spannhülse		Tragzahl dyn.		Tragzahl stat.		Gesamtgewicht Einsatz		Gewicht Einsatz		Wellendurchmesser	
d		D	C	B1	c	B	d1	D1	D2	H1			C _r	C _{or}	[kg]	[kg]	d
[mm]													[kN]	[kN]			[mm]
20	UK205+H	52	17	21	8,0	35	25	34,0	38	4,3	UK205	H2305	14,00	7,88	0,24	0,15	20
25	UK206+H	62	19	25	8,0	38	30	40,3	45	5,0	UK206	H2306	19,50	11,20	0,38	0,25	25
30	UK207+H	72	20	27	9,0	43	35	48,0	52	5,8	UK207	H2307	25,70	15,20	0,54	0,37	30
35	UK208+H	80	21	29	10,0	46	40	53,0	58	6,3	UK208	H2308	29,60	18,20	0,70	0,48	35
40	UK209+H	85	22	30	11,0	50	45	57,2	65	6,8	UK209	H2309	31,85	20,80	0,81	0,53	40
45	UK210+H	90	23	31	12,0	55	50	61,8	70	6,5	UK210	H2310	35,10	23,20	0,95	0,59	45
50	UK211+H	100	25	33	12,5	59	55	69,0	75	7,2	UK211	H2311	43,55	29,20	1,19	0,77	50
55	UK212+H	110	27	36	13,0	62	60	74,9	80	8,2	UK212	H2312	52,50	32,80	1,51	1,03	55
60	UK213+H	120	28	36	14,0	65	65	82,0	85	8,0	UK213	H2313	57,20	40,00	1,92	1,36	60
65	UK215+H	130	30	41	15,0	73	75	91,5	98	9,0	UK215	H2315	66,00	49,50	2,72	1,67	65
70	UK216+H	140	33	44	17,0	78	80	98,0	105	10,3	UK216	H2316	72,50	54,20	3,24	1,96	70
75	UK217+H	150	35	44	18,0	82	85	105,1	110	11,0	UK217	H2317	83,20	63,80	3,87	2,42	75
80	UK218+H	160	37	48	18,0	86	90	111,0	120	12,0	UK218	H2318	96,00	71,50	4,69	3,00	80

Die Größe der entsprechenden Hakenschlüssel können der Seite 22 entnommen werden.

Einsatz

Einsatz mit Gewindestiften UC300 nachschmierbar

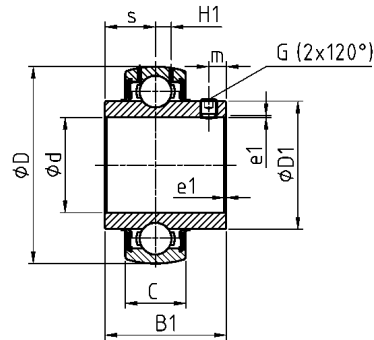
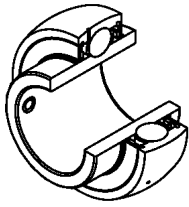

Hauptabmessungen in mm

Wellendurchmesser Einsatz	Hauptabmessungen in mm											Tragzahl dyn.	Tragzahl stat.	Gewicht	Wellendurchmesser	
	d	...G2	D	C	B1	s _{max}	D1	H1	m	G	a*					e1
[mm]													[kN]	[kN]		[mm]
25	UC305	62	21	38	15	35,4	6,2	6,0	M6x1	3	1,5	22,36	11,50	0,35	25	
30	UC306	72	24	43	17	44,6	6,5	6,0	M6x1	3	1,5	27,00	15,20	0,56	30	
35	UC307	80	25	48	19	48,9	7,2	8,0	M8x1	4	2,0	33,50	19,20	0,71	35	
40	UC308	90	28	52	19	56,5	8,5	10,0	M10x1,25	5	2,0	40,56	24,00	0,96	40	
45	UC309	100	30	57	22	61,8	9,0	10,0	M10x1,25	5	2,0	53,00	31,80	1,28	45	
50	UC310	110	32	61	22	68,7	9,9	12,0	M12x1,25	6	2,0	62,00	37,80	1,65	50	
55	UC311	120	34	66	25	74,9	10,6	12,0	M12x1,25	6	2,0	71,50	44,80	1,90	55	
60	UC312	130	36	71	26	81,0	11,3	12,0	M12x1,25	6	2,0	81,60	51,80	2,60	60	
65	UC313	140	38	75	30	87,5	12,1	12,0	M12x1,25	6	2,0	93,86	60,50	3,25	65	
70	UC314	150	40	78	33	94,0	12,8	12,0	M12x1,25	6	2,5	104,26	68,00	3,95	70	
75	UC315	160	42	82	32	100,5	13,5	14,0	M14x1,5	6	2,5	113,36	76,80	4,33	75	
80	UC316	170	44	86	34	107,9	14,5	14,0	M14x1,5	6	3,0	122,85	86,50	5,57	80	
85	UC317	180	46	96	40	114,0	15,5	16,0	M16x1,5	8	3,0	132,60	96,50	6,84	85	
90	UC318	190	48	96	40	120,0	16,5	16,0	M16x1,5	8	3,5	143,00	108,00	7,87	90	
95	UC319	200	50	103	41	126,5	16,7	18,0	M16x1,5	8	3,0	156,00	122,00	8,91	95	
100	UC320	215	54	108	42	134,5	19,0	18,0	M18x1,5	9	3,5	171,60	140,00	11,20	100	
105	UC321	225	57	112	44	140,5	20,0	18,0	M18x1,5	9	3,0	182,00	155,00	12,20	105	
110	UC322	240	60	117	46	149,0	21,0	18,0	M18x1,5	9	3,0	205,00	178,00	14,30	110	
120	UC324	260	64	126	51	163,0	22,0	18,0	M18x1,5	9	3,0	228,00	208,00	18,50	120	
130	UC326	280	68	135	54	177,0	23,0	20,0	M20x1,5	10	4,0	252,00	242,00	23,00	130	
140	UC328	300	73	145	59	190,0	25,0	20,0	M20x1,5	10	4,0	275,00	272,00	28,50	140	

* SW Innensechskant

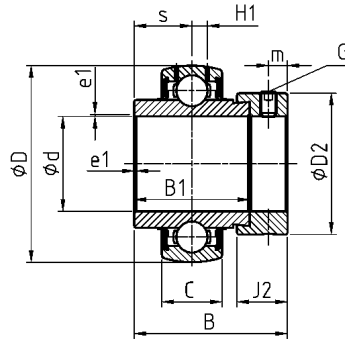
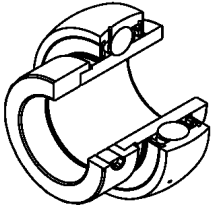

Wellendurchmesser Einsatz		Hauptabmessungen in mm												Tragzahl dyn.		Tragzahl stat.		Gewicht Wellendurchmesser	
d [mm]		D	C	B1	J2	B	s _{max}	D2	H1	m	G	a*	e1	C _r [kN]	C _{0r} [kN]	[kg]	d [mm]		
25	EX305	62	21	34,9	15,9	46,8	16,7	42,8	6,2	6,0	M8x1	4	1,5	22,36	11,50	0,43	25		
30	EX306	72	24	36,5	17,5	50,0	17,5	50,0	6,5	6,7	M8x1	4	1,5	27,00	15,20	0,68	30		
35	EX307	80	25	38,1	17,5	51,6	18,3	55,0	7,2	6,7	M8x1	4	2,0	33,50	19,20	0,80	35		
40	EX308	90	28	41,3	20,6	57,1	19,8	63,5	8,5	8,0	M10x1,25	5	2,0	40,56	24,00	1,08	40		
45	EX309	100	30	42,9	20,6	58,7	19,8	70,0	9,0	8,0	M10x1,25	5	2,0	53,00	31,80	1,45	45		
50	EX310	110	32	49,2	22,2	66,6	24,6	76,2	9,9	8,7	M10x1,25	5	2,0	62,00	37,80	1,86	50		
55	EX311	120	34	55,6	22,2	73,0	27,8	83,0	10,6	9,0	M10x1,25	5	2,0	71,50	44,80	2,30	55		
60	EX312	130	36	61,9	23,9	79,4	31,0	89,0	11,3	9,0	M10x1,25	5	2,0	81,60	51,80	2,89	60		
65	EX313	140	38	65,1	27,0	85,7	32,5	97,0	12,1	11,5	M12x1,25	6	2,0	93,86	60,50	3,66	65		
70	EX314	150	40	68,3	30,2	92,1	34,2	102,0	12,8	12,0	M12x1,25	6	2,5	104,26	68,00	4,50	70		
75	EX315	160	42	74,6	31,8	100,0	37,3	113,0	13,5	13,0	M16x1,5	8	2,5	113,36	76,80	5,34	75		
80	EX316	170	44	81,0	31,8	106,4	40,5	119,0	14,5	13,0	M16x1,5	8	3,0	122,85	86,50	6,70	80		
85	EX317	180	46	84,1	31,8	109,5	42,0	127,0	15,5	13,0	M16x1,5	8	3,0	132,60	96,50	7,96	85		
90	EX318	190	48	87,3	36,5	115,9	43,6	133,0	16,5	14,5	M20x1,5	8	3,0	143,00	108,00	9,10	90		
95	EX319	200	50	93,7	36,5	122,3	46,8	140,0	16,7	14,5	M20x1,5	8	3,0	156,00	122,00	10,40	95		
100	EX320	215	54	100,0	36,5	128,6	50,0	146,0	19,0	14,5	M20x1,5	9	3,5	171,60	140,00	13,00	100		

* SW Innensechskant

Einsatz

Einsatz mit Spannhülse

UK300+H nachschmierbar

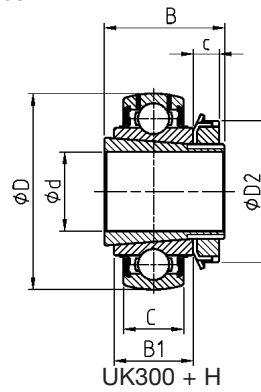
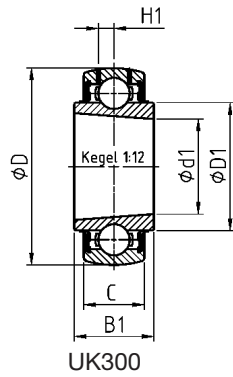
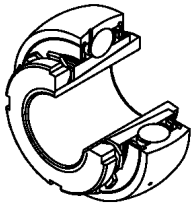

Wellendurchmesser Einsatz + Spannhülse		Hauptabmessungen in mm										Einsatz		Spannhülse		Tragzahl dyn.		Tragzahl stat.		Gesamtgewicht Einsatz		Gewicht Einsatz		Wellendurchmesser	
		d	D	C	B1	c	B	d1	D1	D2	H1														
[mm]												[kN]	[kN]	[kg]	[kg]	[mm]									
20	UK305+H	62	21	27	8,0	35	25	35,4	38	6,2	UK305	H2305	22,36	11,50	0,49	0,40	20								
25	UK306+H	72	24	30	8,0	38	30	44,6	45	6,5	UK306	H2306	27,00	15,20	0,59	0,46	25								
30	UK307+H	80	25	33	9,0	43	35	48,9	52	7,2	UK307	H2307	33,50	19,20	0,92	0,75	30								
35	UK308+H	90	28	35	10,0	46	40	56,5	58	8,5	UK308	H2308	40,56	24,00	1,03	0,81	35								
40	UK309+H	100	30	38	11,0	50	45	61,8	65	9,0	UK309	H2309	53,00	31,80	1,47	1,19	40								
45	UK310+H	110	32	40	12,0	55	50	68,7	70	9,9	UK310	H2310	62,00	37,80	1,74	1,38	45								
50	UK311+H	120	34	43	12,5	59	55	74,9	75	10,6	UK311	H2311	71,50	44,80	2,20	1,78	50								
55	UK312+H	130	36	47	13,0	62	60	81,0	80	11,3	UK312	H2312	81,60	51,80	2,54	2,06	55								
60	UK313+H	140	38	49	14,0	65	65	87,5	85	12,1	UK313	H2313	93,86	60,50	3,27	2,71	60								
65	UK315+H	160	42	55	15,0	73	75	100,5	98	13,5	UK315	H2315	113,36	76,80	5,03	3,98	65								
70	UK316+H	170	44	55	17,0	78	80	107,9	105	14,5	UK316	H2316	122,85	86,50	5,83	4,55	70								
75	UK317+H	180	46	60	18,0	82	85	114,0	110	15,5	UK317	H2317	132,60	96,50	6,89	5,44	75								
80	UK318+H	190	48	60	18,0	86	90	120,0	120	16,5	UK318	H2318	143,00	108,00	7,94	6,25	80								
85	UK319+H	200	50	66	19,0	90	95	126,5	125	16,7	UK319	H2319	156,00	122,00	9,23	7,31	85								
90	UK320+H	215	54	68	20,0	97	100	134,5	130	19,0	UK320	H2320	171,60	140,00	10,97	8,82	90								
100	UK322+H	240	60	80	21,0	105	110	147,7	145	21,0	UK322	H2322	205,00	178,00	17,64	14,90	100								
110	UK324+H	260	64	86	22,0	112	120	162,1	155	22,0	UK324	H2324	228,00	208,00	21,19	18,00	110								
115	UK326+H	280	68	92	23,0	121	130	176,1	165	23,0	UK326	H2326	252,00	242,00	27,90	23,30	115								
125	UK328+H	300	72	98	24,0	131	140	189,0	180	25,0	UK328	H2328	275,00	272,00	34,45	28,90	125								

Die Größe der entsprechenden Hakenschlüssel können der Seite 22 entnommen werden.

**Einsatz mit zylindrischem Außenring
und Gewindestiften**

CUC200 nachschmierbar

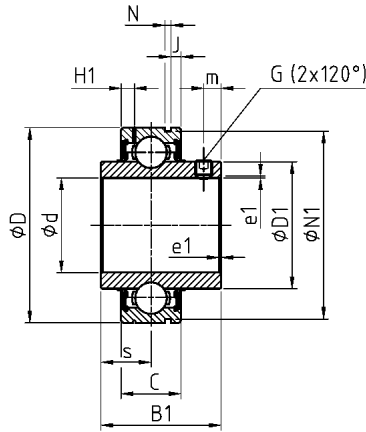
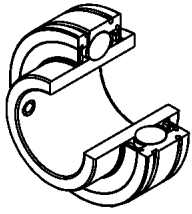

Wellendurchmesser Einsatz		Hauptabmessungen in mm													Tragzahl dyn.		Tragzahl stat.		Gewicht Wellendurchmesser	
d [mm]		D	C	B1	s _{max}	D1	H1	m	N	J	N1	G	a*	e1	C _r [kN]	C _{0r} [kN]	[kg]	d [mm]		
20	CUC204	47	17	31,0	12,7	29,0	4,0	4,5	1,35	3,10	44,60	M6 x 1	3	0,6	12,80	6,65	0,20	20		
25	CUC205	52	17	34,0	14,3	34,0	4,1	5,0	1,35	3,20	49,73	M6 x 1	3	0,6	14,00	7,88	0,21	25		
30	CUC206	62	19	38,1	15,9	40,3	4,2	5,5	1,90	3,20	59,61	M6 x 1	3	0,6	19,50	11,20	0,35	30		
35	CUC207	72	20	42,9	17,5	46,9	5,0	6,5	1,90	3,30	68,81	M8 x 1	4	1,1	25,70	15,20	0,47	35		
40	CUC208	80	21	49,2	19,0	53,0	5,0	8,0	1,90	3,40	76,81	M8 x 1	4	1,1	29,60	18,20	0,64	40		
45	CUC209	85	22	49,2	19,0	57,2	5,1	8,0	1,90	3,50	81,81	M8 x 1	4	1,1	31,85	20,80	0,68	45		
50	CUC210	90	23	51,6	19,0	61,8	5,6	9,0	2,70	3,70	86,79	M10x1,25	5	1,1	35,10	23,20	0,80	50		

* SW Innensechskant

Einsatz

Einsatz mit zylindrischem Außenring
und Gewindestiften

CUS200

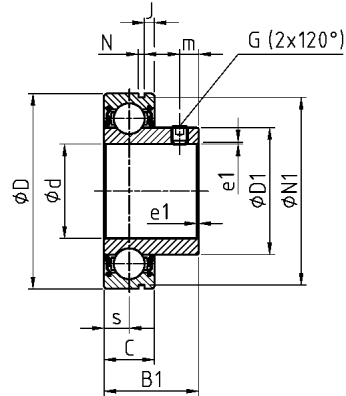
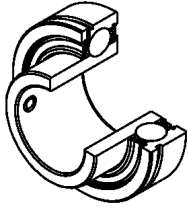

Wellendurchmesser		Hauptabmessungen in mm													Tragzahl dyn.		Tragzahl stat.		Gewicht		Wellendurchmesser	
d	Einsatz	D	C	B1	s_{max}	D1	m	N	J	N1	G	a^*	e1	C_r	C_{Or}	[kg]	d	[mm]				
[mm]														[kN]	[kN]		[mm]					
20	CUS204	47	14	25,0	7,0	28,3	5	1,35	2,38	44,60	M6 x 1	3	1,0	12,80	6,65	0,13	20					
25	CUS205	52	15	27,0	7,5	34,0	5	1,35	2,38	49,73	M6 x 1	3	1,0	14,00	7,88	0,17	25					
30	CUS206	62	16	30,0	8,0	40,0	5,5	1,90	3,18	59,61	M6 x 1	3	1,0	19,50	11,20	0,27	30					
35	CUS207	72	17	32,0	8,5	46,9	6	1,90	3,18	68,81	M6 x 1	3	1,0	25,70	15,20	0,42	35					
40	CUS208	80	18	34,0	9,0	52,4	8	1,90	3,18	76,81	M8 x 1	4	1,0	29,60	18,20	0,48	40					
45	CUS209	85	19	41,2	9,5	57,6	8	1,90	3,18	81,81	M8 x 1	4	1,5	31,85	20,80	0,57	45					
50	CUS210	90	20	43,5	10,0	63,2	9	2,70	3,70	86,79	M8 x 1	4	1,5	35,10	23,20	0,66	50					

* SW Innensechskant

**Einsatz mit zylindrischem Außenring
und Excenterring**

CES200

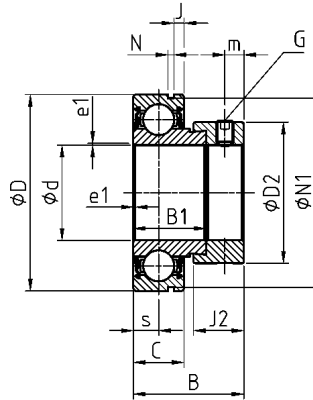
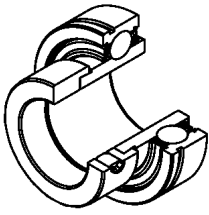

Hauptabmessungen in mm

d [mm]	Einsatz	D	C	B1	J2	B	s _{max}	D2	m	N	J	N1	G	a*	e1	Tragzahl			d
																C _r [kN]	C _{or} [kN]	stat. [kg]	
20	CES204	47	14	21,5	13,5	31,0	7,0	33,3	5,0	1,35	2,38	44,60	M6x1	3	1,0	12,80	6,65	0,15	20
25	CES205	52	15	21,5	13,5	31,0	7,5	38,1	5,0	1,35	2,38	49,73	M6x1	3	1,0	14,00	7,88	0,19	25
30	CES206	62	16	23,8	15,9	35,7	8,0	44,5	6,0	1,90	3,18	59,61	M6x1	3	1,0	19,50	11,20	0,33	30
35	CES207	72	17	25,4	17,5	38,9	8,5	55,6	6,5	1,90	3,18	68,81	M8x1	4	1,5	25,70	15,20	0,50	35
40	CES208	80	18	30,2	18,3	43,7	9,0	60,3	6,5	1,90	3,18	76,81	M8x1	4	1,5	29,60	18,20	0,65	40
45	CES209	85	19	30,2	18,3	43,7	9,5	63,5	6,5	1,90	3,18	81,81	M8x1	4	1,5	31,85	20,80	0,69	45
50	CES210	90	20	30,2	18,3	43,7	10,0	69,9	6,5	2,70	3,70	86,79	M8x1	4	1,5	35,10	23,20	0,80	50

* SW Innensechskant

Einsatz

Einsatz mit zylindrischem Außenring
und Excenterring

CEX200 nachschmierbar

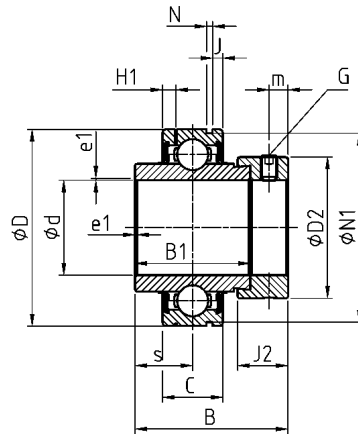
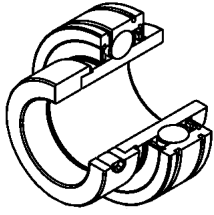

Wellendurchmesser Einsatz	Hauptabmessungen in mm															Tragzahl dyn.	Tragzahl stat.	Gewicht	Wellendurchmesser	
	d	D	C	B1	J2	B	s _{max}	D2	H1	m	N	J	N1	G	a* e1					C _r
[mm]	[mm]	[mm]	[mm]	[mm]	[mm]	[mm]	[mm]	[mm]	[mm]	[mm]	[mm]	[mm]	[mm]	[mm]	[mm]	[kN]	[kN]	[kg]	[mm]	
20	CEX204	47	17	34,2	13,5	43,7	17,1	33,3	4,0	5,0	1,35	3,1	44,60	M6x1	3	1,0	12,80	6,65	0,22	20
25	CEX205	52	17	34,9	13,5	44,4	17,5	38,1	4,1	5,0	1,35	3,2	49,73	M6x1	3	1,0	14,00	7,88	0,25	25
30	CEX206	62	19	36,5	15,9	48,4	18,3	44,5	4,2	6,0	1,90	3,2	59,61	M6x1	3	1,0	19,50	11,20	0,41	30
35	CEX207	72	20	37,6	17,5	51,1	18,8	55,5	5,0	6,5	1,90	3,3	68,81	M8x1	4	1,5	25,70	15,20	0,60	35
40	CEX208	80	21	42,8	18,3	56,3	21,4	60,3	5,0	6,5	1,90	3,4	76,81	M8x1	4	1,5	29,60	18,20	0,78	40
45	CEX209	85	22	42,8	18,3	56,3	21,4	63,5	5,1	6,5	1,90	3,5	81,81	M8x1	4	1,5	31,85	20,80	0,87	45
50	CEX210	90	24	49,2	18,3	62,7	24,6	69,5	5,6	6,5	2,70	3,7	86,79	M8x1	4	1,5	35,10	23,20	1,01	50

* SW Innensechskant

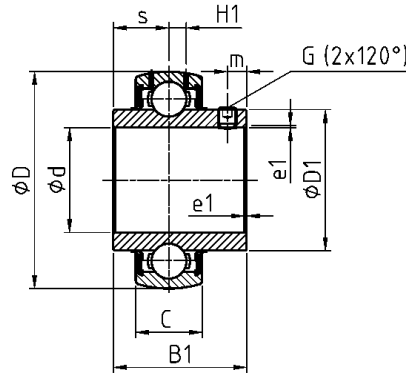
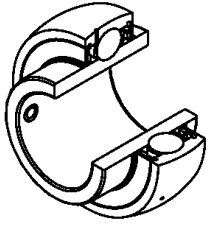

Wellendurchmesser		Einsatz		Hauptabmessungen in mm								Tragzahl dyn.		Tragzahl stat.		Gewicht		Wellendurchmesser	
d		D	C	B1	s _{max}	D1	H1	m	G	a*	e1	C _r	C _{or}	[kg]	d				
[inch]										[inch]		[kN]	[kN]		[inch]				
1/2	UC201-08	47	16	31,0	12,7	29,0	4,4	4,7	1/4-28UNF	1/8	0,6	12,80	6,65	0,21	1/2				
5/8	UC202-10	47	16	31,0	12,7	29,0	4,4	4,7	1/4-28UNF	1/8	0,6	12,80	6,65	0,20	5/8				
11/16	UC203-11	47	16	31,0	12,7	29,0	4,4	4,7	1/4-28UNF	1/8	0,6	12,80	6,65	0,18	11/16				
3/4	UC204-12	47	16	31,0	12,7	29,0	4,4	4,7	1/4-28UNF	1/8	0,6	12,80	6,65	0,17	3/4				
7/8	UC205-14	52	17	34,0	14,3	34,0	4,3	5,5	1/4-28UNF	1/8	0,6	14,00	7,88	0,21	7/8				
15/16	UC205-15	52	17	34,0	14,3	34,0	4,3	5,5	1/4-28UNF	1/8	0,6	14,00	7,88	0,21	15/16				
1	UC205-16	52	17	34,0	14,3	34,0	4,3	5,5	1/4-28UNF	1/8	0,6	14,00	7,88	0,20	1				
1 1/8	UC206-18	62	19	38,1	15,9	40,3	5,0	5,5	1/4-28UNF	1/8	0,6	19,50	11,20	0,34	1 1/8				
1 3/16	UC206-19	62	19	38,1	15,9	40,3	5,0	5,5	1/4-28UNF	1/8	0,6	19,50	11,20	0,31	1 3/16				
1 1/4	UC206-20	62	19	38,1	15,9	40,3	5,0	5,5	1/4-28UNF	1/8	0,6	19,50	11,20	0,30	1 1/4				
1 3/8	UC207-22	72	20	42,9	17,5	48,0	5,8	6,5	5/16-24UNF	5/32	1,1	25,70	15,20	0,48	1 3/8				
1 7/16	UC207-23	72	20	42,9	17,5	48,0	5,8	6,5	5/16-24UNF	5/32	1,1	25,70	15,20	0,45	1 7/16				
1 1/2	UC208-24	80	21	49,2	19,0	53,0	6,3	8,0	5/16-24UNF	5/32	1,1	29,60	18,20	0,68	1 1/2				
1 5/8	UC209-26	85	22	49,2	19,0	57,2	6,8	8,0	5/16-24UNF	5/32	1,1	31,85	20,80	0,78	1 5/8				
1 11/16	UC209-27	85	22	49,2	19,0	57,2	6,8	8,0	5/16-24UNF	5/32	1,1	31,85	20,80	0,74	1 11/16				
1 3/4	UC209-28	85	22	49,2	19,0	57,2	6,8	8,0	5/16-24UNF	5/32	1,1	31,85	20,80	0,70	1 3/4				
1 7/8	UC210-30	90	23	51,6	19,0	61,8	6,5	9,0	3/8-24UNF	3/16	1,1	35,10	23,20	0,87	1 7/8				
1 15/16	UC210-31	90	23	51,6	19,0	61,8	6,5	9,0	3/8-24UNF	3/16	1,1	35,10	23,20	0,82	1 15/16				
2	UC211-32	100	25	55,6	22,2	69,0	7,2	9,0	3/8-24UNF	3/16	1,1	43,55	29,20	1,27	2				
2 3/16	UC211-35	100	25	55,6	22,2	69,0	7,2	9,0	3/8-24UNF	3/16	1,1	43,55	29,20	1,10	2 3/16				
2 1/4	UC212-36	110	27	65,1	25,4	74,9	8,2	10,5	3/8-24UNF	3/16	1,1	52,50	32,80	1,67	2 1/4				
2 7/16	UC212-39	110	27	65,1	25,4	74,9	8,2	10,5	3/8-24UNF	3/16	1,1	52,50	32,80	1,45	2 7/16				
2 1/2	UC213-40	120	28	65,1	25,4	82,0	8,0	12,0	3/8-24UNF	3/16	1,5	57,20	40,00	1,94	2 1/2				
2 11/16	UC214-43	125	30	74,6	30,2	86,5	9,0	12,0	3/8-24UNF	3/16	2,0	62,00	45,00	2,02	2 11/16				
2 3/4	UC214-44	125	30	74,6	30,2	86,5	9,0	12,0	7/16-20UNF	7/32	2,0	62,00	45,00	2,06	2 3/4				
2 15/16	UC215-47	130	30	77,8	33,3	91,5	9,0	12,0	7/16-20UNF	7/32	2,0	66,00	49,50	2,30	2 15/16				
3	UC215-48	130	30	77,8	33,3	91,5	9,0	12,0	7/16-20UNF	7/32	2,0	66,00	49,50	2,13	3				
3 1/4	UC217-52	150	35	85,7	34,1	105,1	11,0	14,0	7/16-20UNF	7/32	2,0	83,20	63,80	3,32	3 1/4				
3 1/2	UC218-56	160	37	96,0	39,7	111,0	12,0	14,0	1/2-20UNF	1/4	2,0	96,00	71,50	4,56	3 1/2				

* SW Innensechskant

Einsatz - inch

Einsatz mit Gewindestiften US200 nachschmierbar

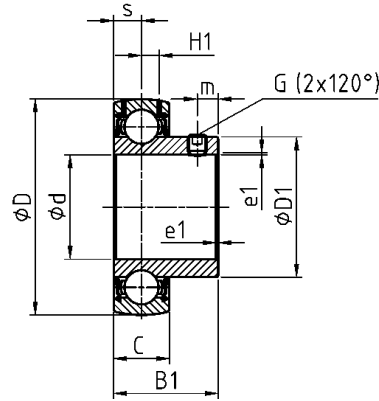
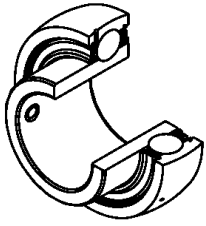

Wellendurchmesser		Einsatz		Hauptabmessungen in mm										Tragzahl dyn.		Tragzahl stat.		Gewicht		Wellendurchmesser	
d		D	C	B1	s _{max}	D1	H1	m	G	a*	e1	C _r	C _{or}			d					
[inch]										[inch]		[kN]	[kN]	[kg]		[inch]					
1/2	US201-08	40	12	22,0	6,0	24,6	3,6	4,0	10-32UNF	3/32	0,6	9,55	4,78	0,09		1/2					
5/8	US202-10	40	12	22,0	6,0	24,6	3,6	4,0	10-32UNF	3/32	0,6	9,55	4,78	0,08		5/8					
11/16	US203-11	40	12	22,0	6,0	24,6	3,6	4,0	10-32UNF	3/32	0,6	9,55	4,78	0,10		11/16					
3/4	US204-12	47	14	25,0	7,0	29,0	4,0	5,0	1/4-28UNF	1/8	0,6	12,80	6,65	0,13		3/4					
7/8	US205-14	52	15	27,0	7,5	34,0	4,3	5,5	1/4-28UNF	1/8	0,6	14,00	7,88	0,18		7/8					
15/16	US205-15	52	15	27,0	7,5	34,0	4,3	5,5	1/4-28UNF	1/8	0,6	14,00	7,88	0,18		15/16					
1	US205-16	52	15	27,0	7,5	34,0	4,3	5,5	1/4-28UNF	1/8	0,6	14,00	7,88	0,16		1					
1 1/8	US206-18	62	16	30,0	8,0	40,3	5,0	6,0	1/4-28UNF	1/8	0,6	19,50	11,20	0,28		1 1/8					
1 3/16	US206-19	62	16	30,0	8,0	40,3	5,0	6,0	1/4-28UNF	1/8	0,6	19,50	11,20	0,25		1 3/16					
1 1/4	US206-20	62	16	30,0	8,0	40,3	5,0	6,0	1/4-28UNF	1/8	0,6	19,50	11,20	0,24		1 1/4					
1 3/8	US207-22	72	17	32,0	8,5	48,0	5,7	6,5	5/16-24UNF	5/32	0,6	25,70	15,20	0,38		1 3/8					
1 7/16	US207-23	72	17	32,0	8,5	48,0	5,7	6,5	5/16-24UNF	5/32	0,6	25,70	15,20	0,37		1 7/16					
1 1/2	US208-24	80	18	34,0	9,0	53,0	6,2	7,0	5/16-24UNF	5/32	1,1	29,60	18,20	0,60		1 1/2					
1 5/8	US209-26	85	19	41,2	10,2	57,2	6,5	8,2	5/16-24UNF	5/32	1,1	31,85	20,80	0,75		1 5/8					
1 11/16	US209-27	85	19	41,2	10,2	57,2	6,5	8,2	5/16-24UNF	5/32	1,1	31,85	20,80	0,72		1 11/16					
1 3/4	US209-28	85	19	41,2	10,2	57,2	6,5	8,2	5/16-24UNF	5/32	1,1	31,85	20,80	0,67		1 3/4					
1 7/8	US210-30	90	20	43,5	10,9	61,8	6,5	9,2	5/16-24UNF	5/32	1,1	35,10	23,20	0,80		1 7/8					
1 15/16	US210-31	90	20	43,5	10,9	61,8	6,5	9,2	5/16-24UNF	5/32	1,1	35,10	23,20	0,78		1 15/16					
2	US211-32	100	23	45,3	11,8	69,0	7,2	9,8	5/16-24UNF	5/32	1,1	43,55	29,20	1,10		2					
2 3/16	US211-35	100	23	45,3	11,8	69,0	7,2	9,8	5/16-24UNF	5/32	1,1	43,55	29,20	1,05		2 3/16					
2 1/4	US212-36	110	24	53,7	14,9	74,9	8,0	9,8	3/8-24UNF	3/16	1,1	52,50	32,80	1,30		2 1/4					
2 7/16	US212-39	110	24	53,7	14,9	74,9	8,0	9,8	3/8-24UNF	3/16	1,1	52,50	32,80	1,22		2 7/16					

* SW Innensechskant

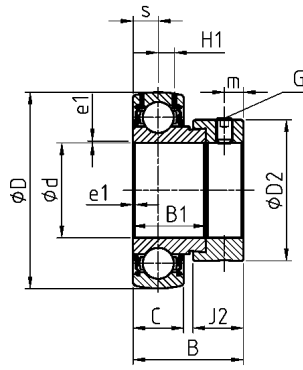
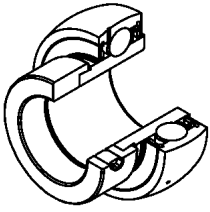

Hauptabmessungen in mm

Wellendurchmesser		Hauptabmessungen in mm													Tragzahl dyn.		Tragzahl stat.		Gewicht		Wellendurchmesser	
d	Einsatz	D	C	B1	J2	B	s _{max}	D2	H1	m	G	a*	e1	C _r	C _{0r}	[kg]	d					
[inch]												[inch]		[kN]	[kN]		[inch]					
1/2	ES201-08	40	12	19,1	13,5	28,6	6,5	28,6	3,6	5,0	1/4-28UNF	1/8	0,6	9,55	4,78	0,14	1/2					
5/8	ES202-10	40	12	19,1	13,5	28,6	6,5	28,6	3,6	5,0	1/4-28UNF	1/8	0,6	9,55	4,78	0,13	5/8					
11/16	ES203-11	40	12	19,1	13,5	28,6	6,5	28,6	3,6	5,0	1/4-28UNF	1/8	0,6	9,55	4,78	0,13	11/16					
3/4	ES204-12	47	14	21,4	13,5	30,9	7,5	33,3	4,0	5,0	1/4-28UNF	1/8	0,6	12,80	6,65	0,15	3/4					
7/8	ES205-14	52	15	21,4	13,5	30,9	7,5	38,1	4,3	5,0	1/4-28UNF	1/8	0,6	14,00	7,88	0,19	7/8					
15/16	ES205-15	52	15	21,4	13,5	30,9	7,5	38,1	4,3	5,0	1/4-28UNF	1/8	0,6	14,00	7,88	0,19	15/16					
1	ES205-16	52	15	21,4	13,5	30,9	7,5	38,1	4,3	5,0	1/4-28UNF	1/8	0,6	14,00	7,88	0,18	1					
1 1/8	ES206-18	62	16	23,8	15,9	35,7	9,0	44,5	5,0	6,0	5/16-24UNF	5/32	0,6	19,50	11,20	0,35	1 1/8					
1 3/16	ES206-19	62	16	23,8	15,9	35,7	9,0	44,5	5,0	6,0	5/16-24UNF	5/32	0,6	19,50	11,20	0,31	1 3/16					
1 1/4	ES206-20	62	16	23,8	15,9	35,7	9,0	44,5	5,0	6,0	5/16-24UNF	5/32	0,6	19,50	11,20	0,28	1 1/4					
1 3/8	ES207-22	72	17	25,4	17,5	38,9	9,5	55,6	5,7	6,5	5/16-24UNF	5/32	1,1	25,70	15,20	0,51	1 3/8					
1 7/16	ES207-23	72	17	25,4	17,5	38,9	9,5	55,6	5,7	6,5	5/16-24UNF	5/32	1,1	25,70	15,20	0,48	1 7/16					
1 1/2	ES208-24	80	18	30,2	18,3	43,7	11,0	60,3	6,2	6,5	5/16-24UNF	5/32	1,1	29,60	18,20	0,68	1 1/2					
1 5/8	ES209-26	85	19	30,2	18,3	43,7	11,0	63,5	6,5	6,5	5/16-24UNF	5/32	1,1	31,85	20,80	0,82	1 5/8					
1 11/16	ES209-27	85	19	30,2	18,3	43,7	11,0	63,5	6,5	6,5	5/16-24UNF	5/32	1,1	31,85	20,80	0,76	1 11/16					
1 3/4	ES209-28	85	19	30,2	18,3	43,7	11,0	63,5	6,5	6,5	5/16-24UNF	5/32	1,1	31,85	20,80	0,73	1 3/4					
1 7/8	ES210-30	90	20	30,2	18,3	43,7	11,0	69,9	6,5	6,5	5/16-24UNF	5/32	1,1	35,10	23,20	0,85	1 7/8					
1 15/16	ES210-31	90	20	30,2	18,3	43,7	11,0	69,9	6,5	6,5	5/16-24UNF	5/32	1,1	35,10	23,20	0,83	1 15/16					
2	ES211-32	100	24	32,5	20,7	48,4	12,0	76,2	7,2	8,0	3/8-24UNF	3/16	1,1	43,55	29,20	1,18	2					
2 3/16	ES211-35	100	24	32,5	20,7	48,4	12,0	76,2	7,2	8,0	3/8-24UNF	3/16	1,1	43,55	29,20	0,81	2 3/16					
2 1/4	ES212-36	110	24	33,4	22,3	49,3	12,0	84,2	8,0	8,0	3/8-24UNF	3/16	1,1	52,50	32,80	1,30	2 1/4					
2 7/16	ES212-39	110	24	33,4	22,3	49,3	12,0	84,2	8,0	8,0	3/8-24UNF	3/16	1,1	52,50	32,80	1,09	2 7/16					

* SW Innensechskant

Einsatz - inch

Einsatz mit Excenterring

EX200 nachschmierbar

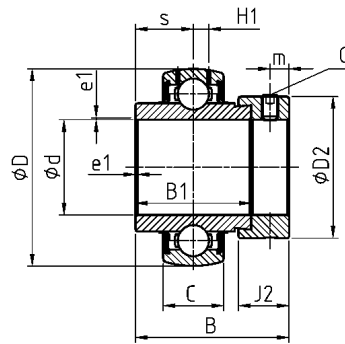
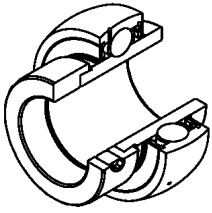

Wellendurchmesser		Hauptabmessungen in mm											Tragzahl dyn.		Tragzahl stat.		Gewicht		Wellendurchmesser
d	Einsatz	D	C	B1	J2	B	s _{max}	D2	H1	m	G	a*	e1	C _r	C _{0r}	[kg]	d		
[inch]												[inch]		[kN]	[kN]		[inch]		
1/2	EX201-08	47	16	34,0	13,5	43,5	17,0	33,3	4,4	5,0	1/4-28UNF	1/8	0,6	12,80	6,65	0,29	1/2		
5/8	EX202-10	47	16	34,0	13,5	43,5	17,0	33,3	4,4	5,0	1/4-28UNF	1/8	0,6	12,80	6,65	0,27	5/8		
11/16	EX203-11	47	16	34,0	13,5	43,5	17,0	33,3	4,4	5,0	1/4-28UNF	1/8	0,6	12,80	6,65	0,24	11/16		
3/4	EX204-12	47	16	34,0	13,5	43,5	17,0	33,3	4,4	5,0	1/4-28UNF	1/8	0,6	12,80	6,65	0,22	3/4		
7/8	EX205-14	52	17	34,8	13,5	44,3	17,4	38,1	4,3	5,0	1/4-28UNF	1/8	0,6	14,00	7,88	0,25	7/8		
15/16	EX205-15	52	17	34,8	13,5	44,3	17,4	38,1	4,3	5,0	1/4-28UNF	1/8	0,6	14,00	7,88	0,25	15/16		
1	EX205-16	52	17	34,8	13,5	44,3	17,4	38,1	4,3	5,0	1/4-28UNF	1/8	0,6	14,00	7,88	0,24	1		
1 1/8	EX206-18	62	19	36,4	15,9	48,3	18,2	44,5	5,0	6,0	5/16-24UNF	5/32	0,6	19,50	11,20	0,43	1 1/8		
1 3/16	EX206-19	62	19	36,4	15,9	48,3	18,2	44,5	5,0	6,0	5/16-24UNF	5/32	0,6	19,50	11,20	0,40	1 3/16		
1 1/4	EX206-20	62	19	36,4	15,9	48,3	18,2	44,5	5,0	6,0	5/16-24UNF	5/32	0,6	19,50	11,20	0,38	1 1/4		
1 3/8	EX207-22	72	20	37,6	17,5	51,1	18,8	55,6	5,8	6,5	5/16-24UNF	5/32	1,1	25,70	15,20	0,61	1 3/8		
1 7/16	EX207-23	72	20	37,6	17,5	51,1	18,8	55,6	5,8	6,5	5/16-24UNF	5/32	1,1	25,70	15,20	0,58	1 7/16		
1 1/2	EX208-24	80	21	42,8	18,3	56,3	21,4	60,3	6,3	6,5	5/16-24UNF	5/32	1,1	29,60	18,20	0,83	1 1/2		
1 5/8	EX209-26	85	22	42,8	18,3	56,3	21,4	63,5	6,8	6,5	5/16-24UNF	5/32	1,1	31,85	20,80	0,96	1 5/8		
1 11/16	EX209-27	85	22	42,8	18,3	56,3	21,4	63,5	6,8	6,5	5/16-24UNF	5/32	1,1	31,85	20,80	0,91	1 11/16		
1 3/4	EX209-28	85	22	42,8	18,3	56,3	21,4	63,5	6,8	6,5	5/16-24UNF	5/32	1,1	31,85	20,80	0,87	1 3/4		
1 7/8	EX210-30	90	23	49,2	18,3	62,7	24,6	69,9	6,5	6,5	5/16-24UNF	5/32	1,1	35,10	23,20	1,10	1 7/8		
1 15/16	EX210-31	90	23	49,2	18,3	62,7	24,6	69,9	6,5	6,5	5/16-24UNF	5/32	1,1	35,10	23,20	1,04	1 15/16		
2	EX211-32	100	25	55,4	20,7	71,3	27,7	76,2	7,2	8,0	3/8-24UNF	3/16	1,5	43,55	29,20	1,58	2		
2 3/16	EX211-35	100	25	55,4	20,7	71,3	27,7	76,2	7,2	8,0	3/8-24UNF	3/16	1,5	43,55	29,20	1,36	2 3/16		
2 1/4	EX212-36	110	27	61,8	22,3	77,7	30,9	84,2	8,2	8,0	3/8-24UNF	3/16	1,5	52,50	32,80	2,03	2 1/4		
2 7/16	EX212-39	110	27	61,8	22,3	77,7	30,9	84,2	8,2	8,0	3/8-24UNF	3/16	1,5	52,50	32,80	1,76	2 7/16		
2 1/2	EX213-40	120	28	68,2	23,5	85,7	34,1	86,0	8,0	8,5	3/8-24UNF	3/16	1,5	57,20	40,00	2,51	2 1/2		
2 11/16	EX214-43	125	30	68,2	23,5	85,7	34,1	96,8	9,0	8,5	3/8-24UNF	3/16	2,0	62,00	45,00	2,62	2 11/16		
2 3/4	EX214-44	125	30	68,2	23,5	85,7	34,1	96,8	9,0	8,5	3/8-24UNF	3/16	2,0	62,00	45,00	2,58	2 3/4		
2 15/16	EX215-47	130	30	74,6	23,9	92,1	37,3	102,0	9,0	8,5	3/8-24UNF	3/16	2,0	66,00	49,50	2,80	2 15/16		
3	EX215-48	130	30	74,6	23,9	92,1	37,3	102,0	9,0	8,5	3/8-24UNF	3/16	2,0	66,00	49,50	2,74	3		
3 1/4	EX217-52	150	35	53,2	27,0	73,2	23,4	119,0	11,0	10,0	7/16-20UNF	7/32	2,0	83,20	63,80	3,65	3 1/4		
3 1/2	EX218-56	160	37	55,0	24,0	72,5	24,5	120,0	10,3	9,5	7/16-20UNF	7/32	2,0	96,00	71,50	5,00	3 1/2		

* SW Innensechskant

Einsatz mit Spannhülse

UK200+H nachschmierbar

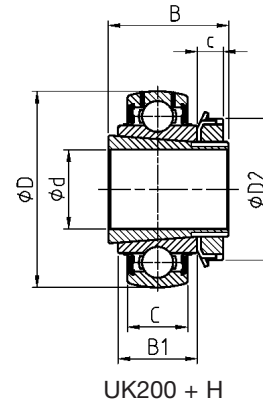
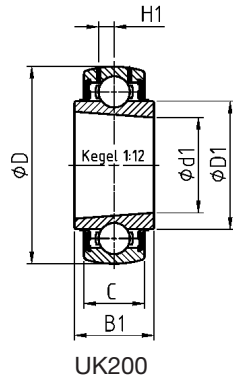
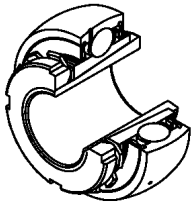

Wellendurchmesser		Einsatz+Spannhülse		Hauptabmessungen in mm							Einsatz		Spannhülse		Tragzahl dyn.		Tragzahl stat.		Gesamtgewicht		Gewicht Einsatz		Wellendurchmesser	
d		D	C	B1	c	B	d1	D1	D2	H1			C _r	C _{or}	[kg]	[kg]			d					
[inch]													[kN]	[kN]					[inch]					
3/4	UK205+H-12	52	17	21	8,0	35	25	34,0	38	4,3	UK205	H2305-12	14,00	7,88	0,24	0,15			3/4					
7/8	UK206+H-14	62	19	25	8,0	38	30	40,3	45	5,0	UK206	H2306-14	19,50	11,20	0,40	0,25			7/8					
15/16	UK206+H-15	62	19	25	8,0	38	30	40,3	45	5,0	UK206	H2306-15	19,50	11,20	0,39	0,25			15/16					
1	UK206+H-16	62	19	25	8,0	38	30	40,3	45	5,0	UK206	H2306-16	19,50	11,20	0,36	0,25			1					
1 1/8	UK207+H-18	72	20	27	9,0	43	35	48,0	52	5,8	UK207	H2307-18	25,70	15,20	0,55	0,37			1 1/8					
1 3/16	UK207+H-19	72	20	27	9,0	43	35	48,0	52	5,8	UK207	H2307-19	25,70	15,20	0,53	0,37			1 3/16					
1 1/4	UK208+H-20	80	21	29	10,0	46	40	53,0	58	6,3	UK208	H2308-20	29,60	18,20	0,76	0,48			1 1/4					
1 3/8	UK208+H-22	80	21	29	10,0	46	40	53,0	58	6,3	UK208	H2308-22	29,60	18,20	0,74	0,48			1 3/8					
1 7/16	UK209+H-23	85	22	30	11,0	50	45	57,2	65	6,8	UK209	H2309-23	31,85	20,80	0,80	0,53			1 7/16					
1 1/2	UK209+H-24	85	22	30	11,0	50	45	57,2	65	6,8	UK209	H2309-24	31,85	20,80	0,84	0,53			1 1/2					
1 5/8	UK210+H-26	90	23	31	12,0	55	50	61,8	70	6,5	UK210	H2310-26	35,10	23,20	1,00	0,59			1 5/8					
1 11/16	UK210+H-27	90	23	31	12,0	55	50	61,8	70	6,5	UK210	H2310-27	35,10	23,20	0,99	0,59			1 11/16					
1 3/4	UK210+H-28	90	23	31	12,0	55	50	61,8	70	6,5	UK210	H2310-28	35,10	23,20	0,95	0,59			1 3/4					
1 7/8	UK211+H-30	100	25	33	12,5	59	55	69,0	75	7,2	UK211	H2311-30	43,55	29,20	1,20	0,77			1 7/8					
1 15/16	UK211+H-31	100	25	33	12,5	59	55	69,0	75	7,2	UK211	H2311-31	43,55	29,20	1,19	0,77			1 15/16					
2	UK211+H-32	100	25	33	12,5	59	55	69,0	75	7,2	UK211	H2311-32	43,55	29,20	1,13	0,77			2					
2 3/16	UK213+H-35	120	28	36	14,0	65	65	82,0	85	8,0	UK213	H2313-35	57,20	40,00	2,11	1,36			2 3/16					
2 1/4	UK213+H-36	120	28	36	14,0	65	65	82,0	85	8,0	UK213	H2313-36	57,20	40,00	2,01	1,36			2 1/4					
2 7/16	UK215+H-39	130	30	41	15,0	73	75	91,5	98	9,0	UK215	H2315-39	66,00	49,50	2,82	1,67			2 7/16					
2 1/2	UK215+H-40	130	30	41	15,0	73	75	91,5	98	9,0	UK215	H2315-40	66,00	49,50	2,81	1,67			2 1/2					
2 11/16	UK216+H-43	140	33	44	17,0	78	80	98,0	105	10,3	UK216	H2316-43	72,50	54,20	3,26	1,96			2 11/16					
2 3/4	UK216+H-44	140	33	44	17,0	78	80	98,0	105	10,3	UK216	H2316-44	72,50	54,20	3,16	1,96			2 3/4					
2 15/16	UK217+H-47	150	35	44	18,0	82	85	105,1	110	11,0	UK217	H2317-47	83,20	63,80	3,82	2,42			2 15/16					
3	UK217+H-48	150	35	44	18,0	82	85	105,1	110	11,0	UK217	H2317-48	83,20	63,80	3,72	2,42			3					

Die Größe der entsprechenden Hakenschlüssel können der Seite 22 entnommen werden.

Einsatz - inch

Einsatz mit Gewindestiften UC300 nachschmierbar

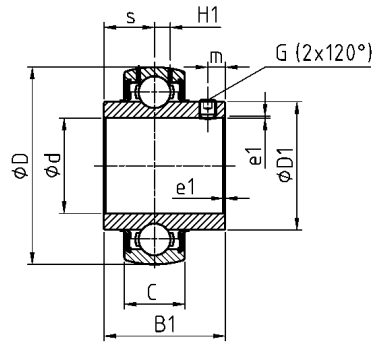
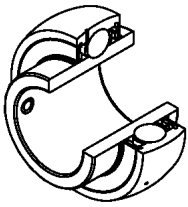

Wellendurchmesser		Hauptabmessungen in mm										Tragzahl dyn.		Tragzahl stat.		Gewicht		Wellendurchmesser	
d	Einsatz	D	C	B1	s _{max}	D1	H1	m	G	a*	e1	C _r	C _{or}	[kg]	d				
[inch]										[inch]		[kN]	[kN]		[inch]				
7/8	UC305-14	62	21	38	15	35,4	6,2	6	1/4-28UNF	1/8	1,5	22,36	11,50	0,35	7/8				
15/16	UC305-15	62	21	38	15	35,4	6,2	6	1/4-28UNF	1/8	1,5	22,36	11,50	0,35	15/16				
1	UC305-16	62	21	38	15	35,4	6,2	6	1/4-28UNF	1/8	1,5	22,36	11,50	0,34	1				
1 1/8	UC306-18	72	24	43	17	44,6	6,5	6	1/4-28UNF	1/8	1,5	27,00	15,20	0,58	1 1/8				
1 3/16	UC306-19	72	24	43	17	44,6	6,5	6	1/4-28UNF	1/8	1,5	27,00	15,20	0,56	1 3/16				
1 1/4	UC307-20	80	25	48	19	48,9	7,2	8	5/16-24UNF	5/32	2,0	33,50	19,20	0,77	1 1/4				
1 3/8	UC307-22	80	25	48	19	48,9	7,2	8	5/16-24UNF	5/32	2,0	33,50	19,20	0,71	1 3/8				
1 7/16	UC307-23	80	25	48	19	48,9	7,2	8	5/16-24UNF	5/32	2,0	33,50	19,20	0,70	1 7/16				
1 1/2	UC308-24	90	28	52	19	56,5	8,5	10	3/8-24UNF	3/16	2,0	40,56	24,00	1,00	1 1/2				
1 5/8	UC309-26	100	30	57	22	61,8	9,0	10	3/8-24UNF	3/16	2,0	53,00	31,80	1,36	1 5/8				
1 11/16	UC309-27	100	30	57	22	61,8	9,0	10	3/8-24UNF	3/16	2,0	53,00	31,80	1,33	1 11/16				
1 3/4	UC309-28	100	30	57	22	61,8	9,0	10	3/8-24UNF	3/16	2,0	53,00	31,80	1,30	1 3/4				
1 7/8	UC310-30	110	32	61	22	68,7	9,9	12	7/16-20UNF	7/32	2,0	62,00	37,80	1,74	1 7/8				
1 15/16	UC310-31	110	32	61	22	68,7	9,9	12	7/16-20UNF	7/32	2,0	62,00	37,80	1,68	1 15/16				
2	UC311-32	120	34	66	25	74,9	10,6	12	7/16-20UNF	7/32	2,0	71,50	44,80	2,08	2				
2 3/16	UC311-35	120	34	66	25	74,9	10,6	12	7/16-20UNF	7/32	2,0	71,50	44,80	1,87	2 3/16				
2 1/4	UC312-36	130	36	71	26	81,0	11,3	12	7/16-20UNF	7/32	2,0	81,60	51,80	2,65	2 1/4				
2 7/16	UC312-39	130	36	71	26	81,0	11,3	12	7/16-20UNF	7/32	2,0	81,60	51,80	2,50	2 7/16				
2 1/2	UC313-40	140	38	75	30	87,5	12,1	12	7/16-20UNF	7/32	2,0	93,86	60,50	3,30	2 1/2				
2 11/16	UC314-43	150	40	78	33	94,0	12,8	12	7/16-20UNF	7/32	2,5	104,26	68,00	4,00	2 11/16				
2 3/4	UC314-44	150	40	78	33	94,0	12,8	12	7/16-20UNF	7/32	2,5	104,26	68,00	3,96	2 3/4				
2 15/16	UC315-47	160	42	82	32	100,5	13,5	14	1/2-20UNF	1/4	2,5	113,36	76,80	4,29	2 15/16				
3	UC315-48	160	42	82	32	100,5	13,5	14	1/2-20UNF	1/4	2,5	113,36	76,80	4,24	3				
3 1/4	UC317-52	180	46	96	40	114,0	15,5	16	5/8-18UNF	5/16	3,0	132,60	96,50	6,76	3 1/4				
3 1/2	UC318-56	190	48	96	40	120,0	16,5	16	5/8-18UNF	5/16	3,5	143,00	108,00	8,03	3 1/2				
3 15/16	UC320-63	215	54	108	42	134,5	19,0	18	5/8-18UNF	5/16	3,5	171,60	140,00	11,00	3 15/16				

* SW Innensechskant

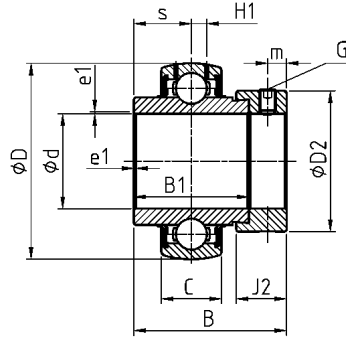
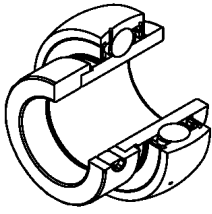

Wellendurchmesser		Hauptabmessungen in mm														Tragzahl dyn.		Tragzahl stat.		Gewicht		Wellendurchmesser	
d	Einsatz	D	C	B1	J2	B	s _{max}	D2	H1	m	G	a*	e1	C _r	C _{or}	[kg]	d						
[inch]												[inch]		[kN]	[kN]		[inch]						
7/8	EX305-14	62	21	34,9	15,9	46,8	16,7	42,8	6,2	6,0	5/16-24UNF	5/32	1,5	22,36	11,50	0,43	7/8						
15/16	EX305-15	62	21	34,9	15,9	46,8	16,7	42,8	6,2	6,0	5/16-24UNF	5/32	1,5	22,36	11,50	0,43	15/16						
1	EX305-16	62	21	34,9	15,9	46,8	16,7	42,8	6,2	6,0	5/16-24UNF	5/32	1,5	22,36	11,50	0,43	1						
1 1/8	EX306-18	72	24	36,5	17,5	50,0	17,5	50,0	6,5	6,7	5/16-24UNF	5/32	1,5	27,00	15,20	0,71	1 1/8						
1 3/16	EX306-19	72	24	36,5	17,5	50,0	17,5	50,0	6,5	6,7	5/16-24UNF	5/32	1,5	27,00	15,20	0,68	1 3/16						
1 1/4	EX307-20	80	25	38,1	17,5	51,6	18,3	55,0	7,2	6,7	5/16-24UNF	5/32	2,0	33,50	19,20	0,86	1 1/4						
1 3/8	EX307-22	80	25	38,1	17,5	51,6	18,3	55,0	7,2	6,7	5/16-24UNF	5/32	2,0	33,50	19,20	0,80	1 3/8						
1 7/16	EX307-23	80	25	38,1	17,5	51,6	18,3	55,0	7,2	6,7	5/16-24UNF	5/32	2,0	33,50	19,20	0,78	1 7/16						
1 1/2	EX308-24	90	28	41,3	20,6	57,1	19,8	63,5	8,5	8,0	3/8-24UNF	3/16	2,0	40,56	24,00	1,13	1 1/2						
1 5/8	EX309-26	100	30	42,9	20,6	58,7	19,8	70,0	9,0	8,0	3/8-24UNF	3/16	2,0	53,00	31,80	1,57	1 5/8						
1 11/16	EX309-27	100	30	42,9	20,6	58,7	19,8	70,0	9,0	8,0	3/8-24UNF	3/16	2,0	53,00	31,80	1,52	1 11/16						
1 3/4	EX309-28	100	30	42,9	20,6	58,7	19,8	70,0	9,0	8,0	3/8-24UNF	3/16	2,0	53,00	31,80	1,47	1 3/4						
1 7/8	EX310-30	110	32	49,2	22,2	66,6	24,6	76,2	9,9	8,7	3/8-24UNF	3/16	2,0	62,00	37,80	1,93	1 7/8						
1 15/16	EX310-31	110	32	49,2	22,2	66,6	24,6	76,2	9,9	8,7	3/8-24UNF	3/16	2,0	62,00	37,80	1,88	1 15/16						
2	EX311-32	120	34	55,6	22,2	73,0	27,8	83,0	10,6	9,0	3/8-24UNF	3/16	2,0	71,50	44,80	2,49	2						
2 3/16	EX311-35	120	34	55,6	22,2	73,0	27,8	83,0	10,6	9,0	3/8-24UNF	3/16	2,0	71,50	44,80	2,24	2 3/16						
2 1/4	EX312-36	130	36	61,9	23,9	79,4	31,0	89,0	11,3	9,0	3/8-24UNF	3/16	2,0	81,60	51,80	2,95	2 1/4						
2 7/16	EX312-39	130	36	61,9	23,9	79,4	31,0	89,0	11,3	9,0	3/8-24UNF	3/16	2,0	81,60	51,80	2,86	2 7/16						
2 1/2	EX313-40	140	38	65,1	27,0	85,7	32,5	97,0	12,1	11,5	7/16-20UNF	7/32	2,0	93,86	60,50	3,85	2 1/2						
2 11/16	EX314-43	150	40	68,3	30,2	92,1	34,2	102,0	12,8	12,0	7/16-20UNF	7/32	2,5	104,26	68,00	4,45	2 11/16						
2 3/4	EX314-44	150	40	68,3	30,2	92,1	34,2	102,0	12,8	12,0	7/16-20UNF	7/32	2,5	104,26	68,00	4,40	2 3/4						
2 15/16	EX315-47	160	42	74,6	31,8	100,0	37,3	113,0	13,5	13,0	5/8-18UNF	5/16	2,5	113,36	76,80	5,40	2 15/16						
3	EX315-48	160	42	74,6	31,8	100,0	37,3	113,0	13,5	13,0	5/8-18UNF	5/16	2,5	113,36	76,80	5,28	3						
3 1/4	EX317-52	180	46	84,1	31,8	109,5	42,0	127,0	15,5	14,0	5/8-18UNF	5/16	3,0	132,60	96,50	7,88	3 1/4						
3 1/2	EX318-56	190	48	87,3	36,5	87,3	43,6	133,0	16,5	15,0	3/4-16UNF	3/8	3,0	143,00	108,00	9,20	3 1/2						
3 15/16	EX320-63	215	54	100,0	36,5	128,6	50,0	146,0	19,0	16,0	3/4-16UNF	3/8	3,5	171,60	140,00	12,85	3 15/16						

* SW Innensechskant

Einsatz - inch

Einsatz mit Spannhülse

UK300+H nachschmierbar

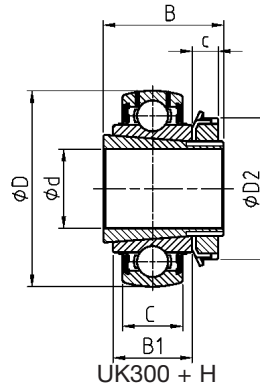
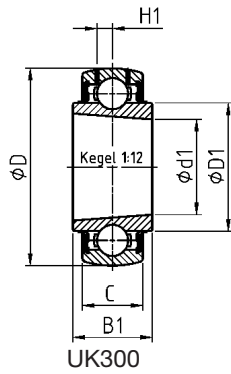
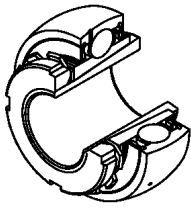

Wellendurchmesser		Einsatz+ Spannhülse		Hauptabmessungen in mm								Einsatz		Spannhülse		Tragzahl dyn.		Tragzahl stat.		Gesamtgewicht		Gewicht Einsatz Wellendurchmesser	
d [inch]		D	C	B1	c	B	d1	D1	D2	H1			C_r [kN]	C_{0r} [kN]	[kg]	[kg]	[kg]	[kg]	[kg]	[kg]	d [inch]		
3/4	UK305+H-12	62	21	27	8,0	35	25	35,4	38	6,2	UK305	H2305-12	22,36	11,50	0,49	0,40					3/4		
7/8	UK306+H-14	72	24	30	8,0	38	30	44,6	45	6,5	UK306	H2306-14	27,00	15,20	0,61	0,46					7/8		
15/16	UK306+H-15	72	24	30	8,0	38	30	44,6	45	6,5	UK306	H2306-15	27,00	15,20	0,60	0,46					15/16		
1	UK306+H-16	72	24	30	8,0	38	30	44,6	45	6,5	UK306	H2306-16	27,00	15,20	0,57	0,46					1		
1 1/8	UK307+H-18	80	25	33	9,0	43	35	48,9	52	7,2	UK307	H2307-18	33,50	19,20	0,93	0,75					1 1/8		
1 3/16	UK307+H-19	80	25	33	9,0	43	35	48,9	52	7,2	UK307	H2307-19	33,50	19,20	0,91	0,75					1 3/16		
1 1/4	UK308+H-20	90	28	35	10,0	46	40	56,5	58	8,5	UK308	H2308-20	40,56	24,00	1,09	0,81					1 1/4		
1 3/8	UK308+H-22	90	28	35	10,0	46	40	56,5	58	8,5	UK308	H2308-22	40,56	24,00	1,09	0,81					1 3/8		
1 7/16	UK309+H-23	100	30	38	11,0	50	45	61,8	65	9,0	UK309	H2309-23	53,00	31,80	1,46	1,19					1 7/16		
1 1/2	UK309+H-24	100	30	38	11,0	50	45	61,8	65	9,0	UK309	H2309-24	53,00	31,80	1,50	1,19					1 1/2		
1 5/8	UK310+H-26	110	32	40	12,0	55	50	68,7	70	9,9	UK310	H2310-26	62,00	37,80	1,68	1,38					1 5/8		
1 11/16	UK310+H-27	110	32	40	12,0	55	50	68,7	70	9,9	UK310	H2310-27	62,00	37,80	1,78	1,38					1 11/16		
1 3/4	UK310+H-28	110	32	40	12,0	55	50	68,7	70	9,9	UK310	H2310-28	62,00	37,80	1,74	1,38					1 3/4		
1 7/8	UK311+H-30	120	34	43	12,5	59	55	74,9	75	10,6	UK311	H2311-30	71,50	44,80	2,21	1,78					1 7/8		
1 15/16	UK311+H-31	120	34	43	12,5	59	55	74,9	75	10,6	UK311	H2311-31	71,50	44,80	2,20	1,78					1 15/16		
2	UK311+H-32	120	34	43	12,5	59	55	74,9	75	10,6	UK311	H2311-32	71,50	44,80	2,14	1,78					2		
2 3/16	UK313+H-35	140	38	49	14,0	65	65	87,5	85	12,1	UK313	H2313-35	93,86	60,50	3,46	2,71					2 3/16		
2 1/4	UK313+H-36	140	38	49	14,0	65	65	87,5	85	12,1	UK313	H2313-36	93,86	60,50	3,36	2,71					2 1/4		
2 7/16	UK315+H-39	160	42	55	15,0	73	75	100,5	98	13,5	UK315	H2315-39	113,36	76,80	5,13	3,98					2 7/16		
2 1/2	UK315+H-40	160	42	55	15,0	73	75	100,5	98	13,5	UK315	H2315-40	113,36	76,80	5,10	3,98					2 1/2		
2 11/16	UK316+H-43	170	44	55	17,0	78	80	107,9	105	14,5	UK316	H2316-43	122,85	86,50	5,85	4,55					2 11/16		
2 3/4	UK316+H-44	170	44	55	17,0	78	80	107,9	105	14,5	UK316	H2316-44	122,85	86,50	5,75	4,55					2 3/4		
2 15/16	UK317+H-47	180	46	60	18,0	82	85	114,0	110	15,5	UK317	H2317-47	132,60	96,50	6,84	5,44					2 15/16		
3	UK317+H-48	180	46	60	18,0	82	85	114,0	110	15,5	UK317	H2317-48	132,60	96,50	6,74	5,44					3		
3 1/4	UK319+H-55	200	50	66	19,0	90	95	126,5	125	16,7	UK319	H2319-55	156,00	122,00	9,66	7,31					3 1/4		
3 1/2	UK320+H-56	215	54	68	20,0	97	100	134,5	130	19,0	UK320	H2320-56	171,60	140,00	10,62	8,82					3 1/2		

Die Größe der entsprechenden Hakenschlüssel können der Seite 22 entnommen werden.

Einsatz mit zylindrischem Außenring
und Gewindestiften

CUC200 nachschmierbar

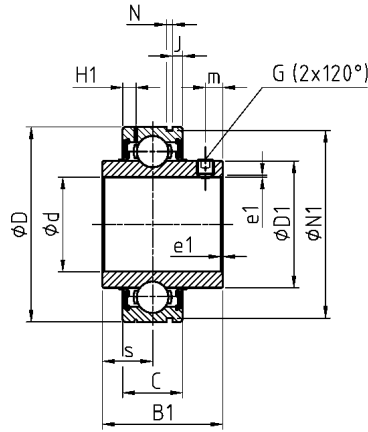
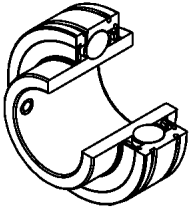

Hauptabmessungen in mm

Wellendurchmesser [inch]	Einsatz	Hauptabmessungen in mm											Tragzahl dyn. [kN]	Tragzahl stat. [kN]	Gewicht [kg]	Wellendurchmesser [inch]		
		D	C	B1	s _{max}	D1	H1	m	N	J	N1	G					a*	e1
3/4	CUC204-12	47	17	31,0	12,7	29,0	4,0	4,5	1,35	3,1	44,60	1/4-28UNF	1/8	0,6	12,80	6,65	0,20	3/4
7/8	CUC205-14	52	17	34,0	14,3	34,0	4,1	5,0	1,35	3,2	49,73	1/4-28UNF	1/8	0,6	14,00	7,88	0,21	7/8
15/16	CUC205-15	52	17	34,0	14,3	34,0	4,1	5,0	1,35	3,2	49,73	1/4-28UNF	1/8	0,6	14,00	7,88	0,21	15/16
1	CUC205-16	52	17	34,0	14,3	34,0	4,1	5,0	1,35	3,2	49,73	1/4-28UNF	1/8	0,6	14,00	7,88	0,21	1
1 1/8	CUC206-18	62	19	38,1	15,9	40,3	4,2	5,5	1,90	3,2	59,61	1/4-28UNF	1/8	0,6	19,50	11,20	0,34	1 1/8
1 3/16	CUC206-19	62	19	38,1	15,9	40,3	4,2	5,5	1,90	3,2	59,61	1/4-28UNF	1/8	0,6	19,50	11,20	0,31	1 3/16
1 1/4	CUC206-20	62	19	38,1	15,9	40,3	4,2	5,5	1,90	3,2	59,61	1/4-28UNF	1/8	0,6	19,50	11,20	0,30	1 1/4
1 3/8	CUC207-22	72	20	42,9	17,5	46,9	5,0	6,5	1,90	3,3	68,81	5/16-24UNF	5/32	1,1	25,70	15,20	0,48	1 3/8
1 7/16	CUC207-23	72	20	42,9	17,5	46,9	5,0	6,5	1,90	3,3	68,81	5/16-24UNF	5/32	1,1	25,70	15,20	0,45	1 7/16
1 1/2	CUC208-24	80	21	49,2	19,0	53,0	5,0	8,0	1,90	3,4	76,81	5/16-24UNF	5/32	1,1	29,60	18,20	0,68	1 1/2
1 5/8	CUC209-26	85	22	49,2	19,0	57,2	5,1	8,0	1,90	3,5	81,81	5/16-24UNF	5/32	1,1	31,85	20,80	0,78	1 5/8
1 11/16	CUC209-27	85	22	49,2	19,0	57,2	5,1	8,0	1,90	3,5	81,81	5/16-24UNF	5/32	1,1	31,85	20,80	0,74	1 11/16
1 3/4	CUC209-28	85	22	49,2	19,0	57,2	5,1	8,0	1,90	3,5	81,81	5/16-24UNF	5/32	1,1	31,85	20,80	0,70	1 3/4
1 7/8	CUC210-30	90	23	51,6	19,0	61,8	5,6	9,0	2,70	3,7	86,79	3/8-24UNF	3/16	1,1	35,10	23,20	0,80	1 7/8
1 15/16	CUC210-31	90	23	51,6	19,0	61,8	5,6	9,0	2,70	3,7	86,79	3/8-24UNF	3/16	1,1	35,10	23,20	0,82	1 15/16

* SW Innensechskant

Einsatz - inch

Einsatz mit zylindrischem Außenring
und Gewindestiften

CUS200

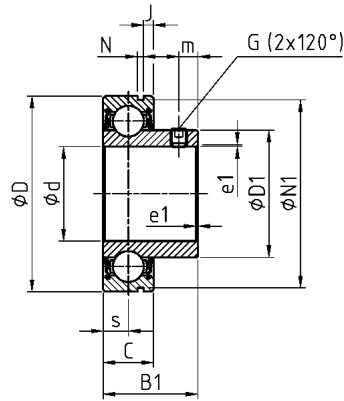
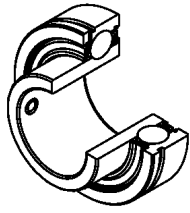

Wellendurchmesser		Einsatz		Hauptabmessungen in mm										Tragzahl dyn.		Tragzahl stat.		Gewicht		Wellendurchmesser	
d		D	C	B1	s _{max}	D1	m	N	J	N1	G	a*	e1	C _r	C _{or}			d			
[inch]												[inch]		[kN]	[kN]	[kg]		[inch]			
3/4	CUS204-12	47	14	25,0	7,0	28,3	5	1,35	2,38	44,60	1/4-28UNF	1/8	1,0	12,80	6,65	0,13		3/4			
7/8	CUS205-14	52	15	27,0	7,5	34,0	5	1,35	2,38	49,73	1/4-28UNF	1/8	1,0	14,00	7,88	0,18		7/8			
15/16	CUS205-15	52	15	27,0	7,5	34,0	5	1,35	2,38	49,73	1/4-28UNF	1/8	1,0	14,00	7,88	0,18		15/16			
1	CUS205-16	52	15	27,0	7,5	34,0	5	1,35	2,38	49,73	1/4-28UNF	1/8	1,0	14,00	7,88	0,18		1			
1 1/8	CUS206-18	62	16	30,0	8,0	40,0	5,5	1,90	3,18	59,61	1/4-28UNF	1/8	1,0	19,50	11,20	0,28		1 1/8			
1 3/16	CUS206-19	62	16	30,0	8,0	40,0	5,5	1,90	3,18	59,61	1/4-28UNF	1/8	1,0	19,50	11,20	0,25		1 3/16			
1 1/4	CUS206-20	62	16	30,0	8,0	40,0	5,5	1,90	3,18	59,61	1/4-28UNF	1/8	1,0	19,50	11,20	0,24		1 1/4			
1 3/8	CUS207-22	72	17	32,0	8,5	46,9	6	1,90	3,18	68,81	1/4-28UNF	1/8	1,0	25,70	15,20	0,38		1 3/8			
1 7/16	CUS207-23	72	17	32,0	8,5	46,9	6	1,90	3,18	68,81	1/4-28UNF	1/8	1,0	25,70	15,20	0,37		1 7/16			
1 1/2	CUS208-24	80	18	34,0	9,0	52,4	8	1,90	3,18	76,81	5/16-24UNF	5/32	1,0	29,60	18,20	0,60		1 1/2			
1 5/8	CUS209-26	85	19	41,2	9,5	57,6	8	1,90	3,18	81,81	5/16-24UNF	5/32	1,5	31,85	20,80	0,75		1 5/8			
1 11/16	CUS209-27	85	19	41,2	9,5	57,6	8	1,90	3,18	81,81	5/16-24UNF	5/32	1,5	31,85	20,80	0,72		1 11/16			
1 3/4	CUS209-28	85	19	41,2	9,5	57,6	8	1,90	3,18	81,81	5/16-24UNF	5/32	1,5	31,85	20,80	0,67		1 3/4			
1 7/8	CUS210-30	90	20	43,5	10,0	63,2	9	2,70	3,70	86,79	5/16-24UNF	5/32	1,5	35,10	23,20	0,80		1 7/8			
1 15/16	CUS210-31	90	20	43,5	10,0	63,2	9	2,70	3,70	86,79	5/16-24UNF	5/32	1,5	35,10	23,20	0,78		1 15/16			

* SW Innensechskant

Einsatz mit zylindrischem Außenring und Excenterring

CES200

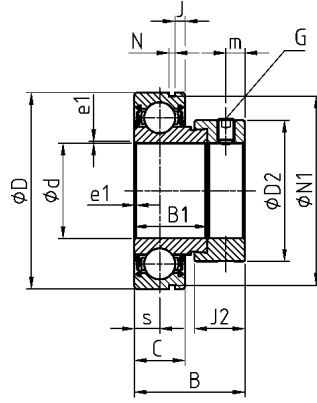
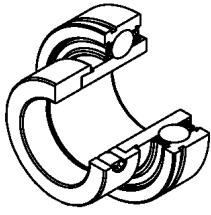

Wellendurchmesser		Einsatz		Hauptabmessungen in mm													Tragzahl d/n.		Tragzahl stat.		Gewicht		Wellendurchmesser	
d		D	C	B1	J2	B	s _{max}	D2	m	N	J	N1	G	a*	e1	C _r	C _{0r}			d				
[inch]														[inch]		[kN]	[kN]	[kg]		[inch]				
3/4	CES204-12	47	14	21,5	13,5	31,0	7,0	33,3	5,0	1,35	2,38	44,60	1/4-28UNF	1/8	1,0	12,80	6,65	0,15		3/4				
7/8	CES205-14	52	15	21,5	13,5	31,0	7,5	38,1	5,0	1,35	2,38	49,73	1/4-28UNF	1/8	1,0	14,00	7,88	0,19		7/8				
15/16	CES205-15	52	15	21,5	13,5	31,0	7,5	38,1	5,0	1,35	2,38	49,73	1/4-28UNF	1/8	1,0	14,00	7,88	0,19		15/16				
1	CES205-16	52	15	21,5	13,5	31,0	7,5	38,1	5,0	1,35	2,38	49,73	1/4-28UNF	1/8	1,0	14,00	7,88	0,18		1				
1 1/8	CES206-18	62	16	23,8	15,9	35,7	8,0	44,5	6,0	1,90	3,18	59,61	5/16-24UNF	5/32	1,0	19,50	11,20	0,35	1	1/8				
1 3/16	CES206-19	62	16	23,8	15,9	35,7	8,0	44,5	6,0	1,90	3,18	59,61	5/16-24UNF	5/32	1,0	19,50	11,20	0,31	1	3/16				
1 1/4	CES206-20	62	16	23,8	15,9	35,7	8,0	44,5	6,0	1,90	3,18	59,61	5/16-24UNF	5/32	1,0	19,50	11,20	0,28	1	1/4				
1 3/8	CES207-22	72	17	25,4	17,5	38,9	8,5	55,6	6,5	1,90	3,18	68,81	5/16-24UNF	5/32	1,5	25,70	15,20	0,51	1	3/8				
1 7/16	CES207-23	72	17	25,4	17,5	38,9	8,5	55,6	6,5	1,90	3,18	68,81	5/16-24UNF	5/32	1,5	25,70	15,20	0,48	1	7/16				
1 1/2	CES208-24	80	18	30,2	18,3	43,7	9,0	60,3	6,5	1,90	3,18	76,81	5/16-24UNF	5/32	1,5	29,60	18,20	0,68	1	1/2				
1 5/8	CES209-26	85	19	30,2	18,3	43,7	9,5	63,5	6,5	1,90	3,18	81,81	5/16-24UNF	5/32	1,5	31,85	20,80	0,82	1	5/8				
1 11/16	CES209-27	85	19	30,2	18,3	43,7	9,5	63,5	6,5	1,90	3,18	81,81	5/16-24UNF	5/32	1,5	31,85	20,80	0,76	1	11/16				
1 3/4	CES209-28	85	19	30,2	18,3	43,7	9,5	63,5	6,5	1,90	3,18	81,81	5/16-24UNF	5/32	1,5	31,85	20,80	0,73	1	3/4				
1 7/8	CES210-30	90	20	30,2	18,3	43,7	10,0	69,9	6,5	2,70	3,70	86,79	5/16-24UNF	5/32	1,5	35,10	23,20	0,85	1	7/8				
1 15/16	CES210-31	90	20	30,2	18,3	43,7	10,0	69,9	6,5	2,70	3,70	86,79	5/16-24UNF	5/32	1,5	35,10	23,20	0,83	1	15/16				

* SW Innensechskant

Einsatz - inch

Einsatz mit zylindrischem Außenring
und Excenterring

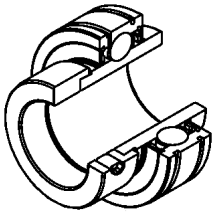

CEX200 nachschmierbar

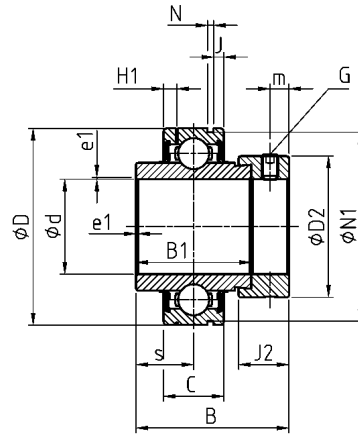

Hauptabmessungen in mm

Wellendurchmesser Einsatz	d [inch]	Hauptabmessungen in mm													Tragzahl dyn.	Tragzahl stat.	Gewicht	Wellendurchmesser		
		D	C	B1	J2	B	s _{max}	D2	H1	m	N	J	N1	G					a* [inch]	e1
3/4	CEX204-12	47	17	34,2	13,5	43,7	17,1	33,3	4,0	5,0	1,35	3,1	44,60	1/4-28UNF	1/8	1,0	12,80	6,65	0,22	3/4
7/8	CEX205-14	52	17	34,9	13,5	44,4	17,5	38,1	4,1	5,0	1,35	3,2	49,73	1/4-28UNF	1/8	1,0	14,00	7,88	0,25	7/8
15/16	CEX205-15	52	17	34,9	13,5	44,4	17,5	38,1	4,1	5,0	1,35	3,2	49,73	1/4-28UNF	1/8	1,0	14,00	7,88	0,25	15/16
1	CEX205-16	52	17	34,9	13,5	44,4	17,5	38,1	4,1	5,0	1,35	3,2	49,73	1/4-28UNF	1/8	1,0	14,00	7,88	0,24	1
1 1/8	CEX206-18	62	19	36,5	15,9	48,4	18,3	44,5	4,2	6,0	1,90	3,2	59,61	5/16-24UNF	5/32	1,0	19,50	11,20	0,43	1 1/8
1 3/16	CEX206-19	62	19	36,5	15,9	48,4	18,3	44,5	4,2	6,0	1,90	3,2	59,61	5/16-24UNF	5/32	1,0	19,50	11,20	0,40	1 3/16
1 1/4	CEX206-20	62	19	36,5	15,9	48,4	18,3	44,5	4,2	6,0	1,90	3,2	59,61	5/16-24UNF	5/32	1,0	19,50	11,20	0,38	1 1/4
1 3/8	CEX207-22	72	20	37,6	17,5	51,1	18,8	55,5	5,0	6,5	1,90	3,3	68,81	5/16-24UNF	5/32	1,5	25,70	15,20	0,61	1 3/8
1 7/16	CEX207-23	72	20	37,6	17,5	51,1	18,8	55,5	5,0	6,5	1,90	3,3	68,81	5/16-24UNF	5/32	1,5	25,70	15,20	0,58	1 7/16
1 1/2	CEX208-24	80	21	42,8	18,3	56,3	21,4	60,3	5,0	6,5	1,90	3,4	76,81	5/16-24UNF	5/32	1,5	29,60	18,20	0,83	1 1/2
1 5/8	CEX209-26	85	22	42,8	18,3	56,3	21,4	63,5	5,1	6,5	1,90	3,5	81,81	5/16-24UNF	5/32	1,5	31,85	20,80	0,96	1 5/8
1 11/16	CEX209-27	85	22	42,8	18,3	56,3	21,4	63,5	5,1	6,5	1,90	3,5	81,81	5/16-24UNF	5/32	1,5	31,85	20,80	0,91	1 11/16
1 3/4	CEX209-28	85	22	42,8	18,3	56,3	21,4	63,5	5,1	6,5	1,90	3,5	81,81	5/16-24UNF	5/32	1,5	31,85	20,80	0,87	1 3/4
1 7/8	CEX210-30	90	24	49,2	18,3	62,7	24,6	69,5	5,6	6,5	3,70	3,7	86,79	5/16-24UNF	5/32	1,5	35,10	23,20	1,10	1 7/8
1 15/16	CEX210-31	90	24	49,2	18,3	62,7	24,6	69,5	5,6	6,5	3,70	3,7	86,79	5/16-24UNF	5/32	1,5	35,10	23,20	1,04	1 15/16

* SW Innensechskant



Toleranzen Graugussgehäuse

Toleranz sphärische Gehäusebohrung

Nennmaß Gehäusebohrung D1 [mm]		Passung
über	bis	
	180	J7
180	300	H7

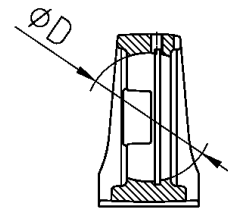

Toleranzen Stehlagergehäuse

Gehäuse							Toleranzen [μm]	
P	PLE	PE	PH / PG	PA / PAE	PP	H	J	
203		203	203	203	203	±150	±700	
204		204	204	204	204			
205	305	205	205	205	205			
206	306	206	206	206	206			
207	307	207	207	207	207			
208	308	208	208	208				
209	309	209	209	209				
210	310	210	210	210				
211	311	211		211				
212	312	212		212				
213	313					±200	±1000	
214	314	214						
215	315	215						
216	316	216						
217	317	217						
218	318	218						
	319							±300
	320							
	321							
	322							
	324							
	326							
	328							

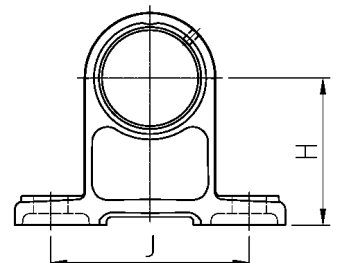
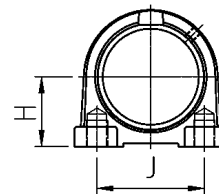
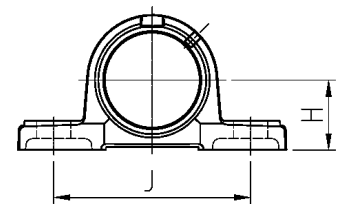

Toleranzen Hülsenlagergehäuse

Gehäuse	Toleranzen [μm]			Radial- schlag max.
	H		A	
C200	oberes	unteres		
203	0	-30	± 200	200
204				
205				
206	0	-35		
207				
208				
209	0	-40	± 300	300
210				
211				
212				
213				
214				
215	0	-46		
216				

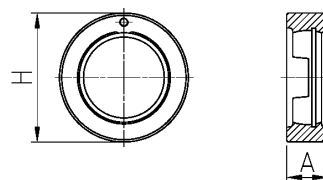

Gehäuse	Toleranzen [μm]			Radial- schlag max.		
	H		A			
C300	oberes	unteres				
305	0	-35	± 200	200		
306						
307						
308	0	-40			± 300	300
309						
310						
311	0	-46	± 400			
312						
313						
314	0	-52				
315						
316	0	-57				
317						
318	0	-57				
319						
320						
321						
322	0	-57				
324						
326	0	-57				
328						

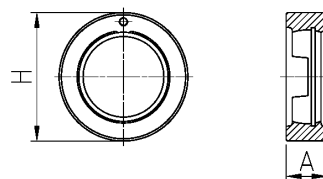



Toleranzen Flanschlagergehäuse

Gehäuse											
F	FE	FCE	FC	FEE	FS	FTE	FLE	FL		FLZ	
203		203		203			203	203	203		
204		204	204	204			204	204	204		204
205	305	205	205	205	205	305	205	205	205	305	205
206	306	206	206	206	206	306	206	206	206	306	206
207	307	207	207	207	207	307	207	207	207	307	207
208	308	208	208	208	208	308	208	208	208	308	208
209	309	209	209	209	209	309	209	209	209	309	209
210	310	210	210	210	210	310	210	210	210	310	210
211	311	211	211	211		311		211	211	311	
212	312	212	212	212	212	312		212	212	312	212
213	313	213	213	213		313			213	313	
214	314	214	214	214		314		214	214	314	
215	315	215	215	215		315		215	215	315	
216	316	216	216	216		316			216	316	
217	317	217	217	217		317			217	317	
218	318	218	218	218		318			218	318	
	319					319				319	
	320					320				320	
	321					321				321	
	322					322				322	
	324					324				324	
	326					326				326	
	328					328				328	

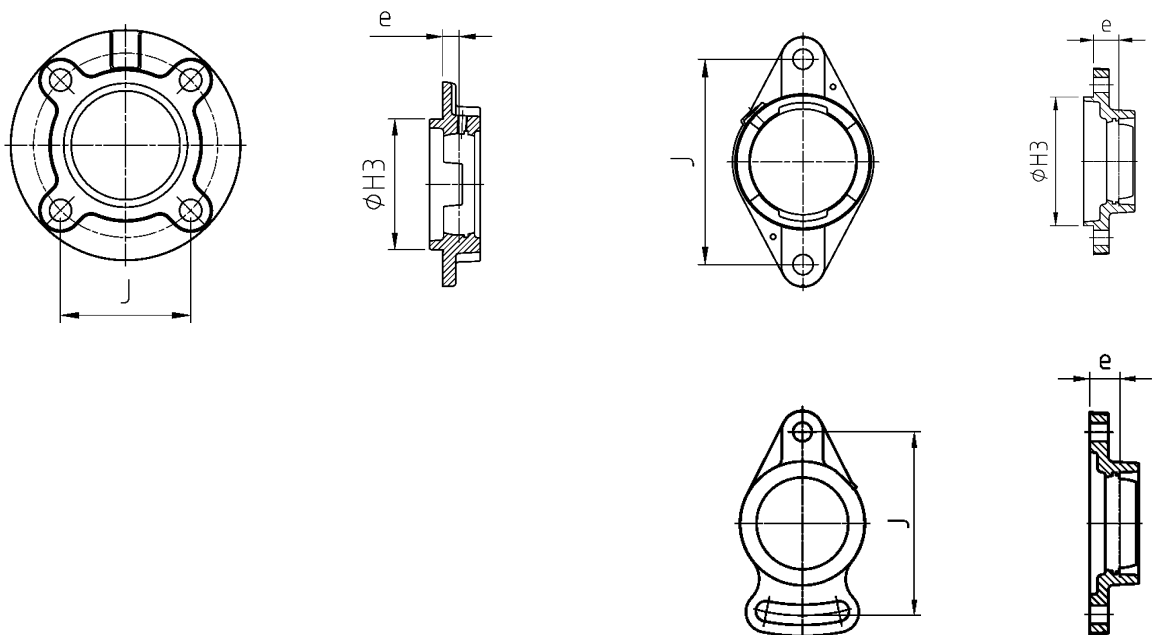

			Toleranzen [μm]			Radial- schlag max.
FD	FA	FAE	J	e	H3	
203	203		± 700	± 500	h8	200
204	204	204				
205	205	205				
206	206	206				
207	207	207				
208	208		± 1000	± 800	h8	300
	209					
	210					
	211					
	212					
						400

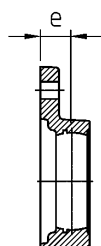
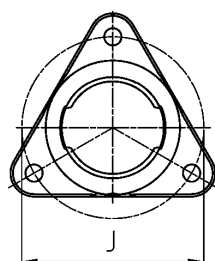
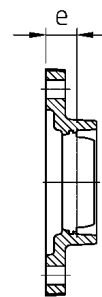
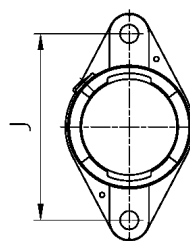
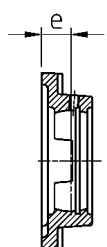
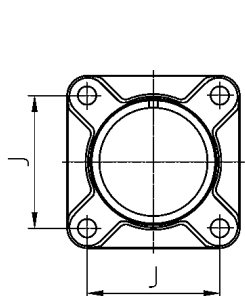



Toleranzen Spannplattenlager

Gehäuse		Toleranzen [μm]				Parallelität Führungsnut max.
		J1		J2		
T		oberes	unteres	oberes	unteres	
204		+200	0	0	-500	500
205	305					
206	306					
207	307					
208	308					
209	309					
210	310	+300	0	0	-800	600
211	311					
212	312					
213	313					
214	314					
215	315					
216	316					700
217	317					
218	318					
	319					
	320					
	321					
	322					
	324	800				
	326					
	328					

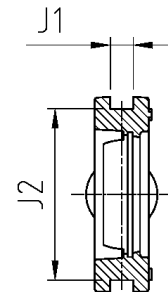
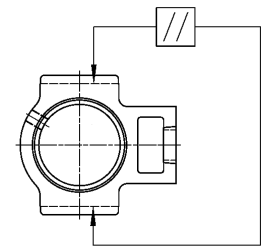

Toleranzen Spannrahmen

Gehäuse	Toleranzen [μm]		
	m	J	e
WB 204 - 213	± 700	± 700	± 500

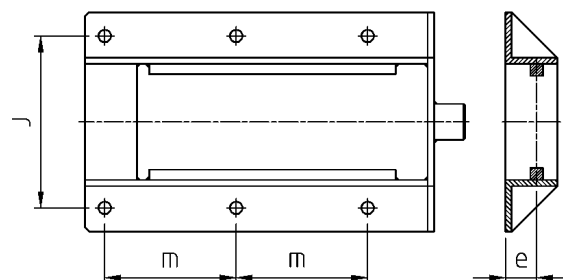

Toleranzen Zubehör Spannrahmen

Gehäuse	Maße [mm]				
	Führungsschiene		Gewindespindel Mutter		
T200	J2' ±0,5	J1'	ds	q	o
204	77	11	16	28	12
205	90		20	32	
206			24	42	
207	103	15	24	42	14
208					
209	131	20	30	56	20
210				60	26
211	152	24	30	56	20
212				60	26
213	152	24	30	60	26

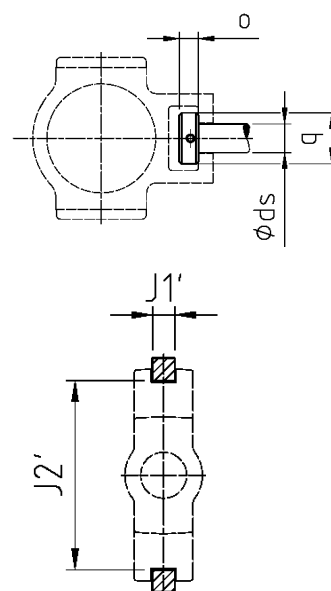

Gehäuse	Maße [mm]				
	Führungsschiene		Gewindespindel Mutter		
T300	J2' ±0,5	J1'	ds	q	o
305	81	11	22	32	12
306	91	15	24	38	14
307	101	16	26	40	16
308	113		28	46	18
309	126		30	50	20
310	141	18	32	55	22
311	151	20	34	60	24
312	161	24	36	64	26
313	172		38	75	
314	182		42	75	
315	194	28	46	90	34
316	206				
317	216	30	50	95	38
318	230				
319	242	32	52	100	38
320	262				
321	287				
322	287	36	55	110	42
326	322	42	60	120	48
326	352	46	65	130	52
328	382	70	140	140	56



Gehäusefixierung

Verstiftung

Um eine genaue Positionierung der Gehäuselager bei der Montage zu ermöglichen, sind die nachfolgend aufgeführten Gussgehäuse mit zusätzlichen Auflageflächen zur Positionierung von Stiften versehen.

Gehäuse Bezeichnung		Maße [mm]			
P	PH	a	b	Gehäuse- dicke	Empf. Stift-Ø
203	203	5,0	8,0	15	3
204	204	5,0	8,0	15	3
205	205	6,0	9,0	16	3
206	206	6,0	13,0	18	3
207	207	6,0	11,0	19	4
208	208	9,0	12,0	19	4
209	209	9,0	12,0	20	5
210	210	10,0	13,0	22	5
211		10,0	13,0	22	6
212		10,0	17,0	25	6
213		9,0	18,5	27	6
214		9,0	15,0	27	6
215		9,5	16,0	28	6
216		11,0	17,0	30	8
217		11,0	17,0	32	8
218		11,0	18,0	34	10
305		5,5	12,5	16	4
306		6,5	11,5	19	4
307		8,0	13,0	21	5
308		9,0	13,0	23	5
309		10,0	14,0	25	6
310		10,0	15,0	28	6
311		12,0	19,0	31	8
312		13,0	22,5	33	8
313		12,5	22,0	36	10
314		13,0	21,0	40	10
315		13,0	26,0	40	10
316		15,0	30,0	45	10
317		15,0	30,0	45	10
318		15,0	30,0	50	10
319		20,0	32,0	50	10
320		20,0	32,0	55	13
321		20,0	32,0	55	13
322		22,5	35,0	60	13
324		25,0	35,0	70	13
326		29,0	35,0	80	13
328		29,0	35,0	80	16

Gehäuse Bezeichnung		Maße [mm]			
F		a	b	Gehäuse- dicke	Empf. Stift-Ø
203		6	30	9	3
204		6	30	9	3
205		6	34	9	3
206		6	35	10	3
207		7	38	12	4
208		8	40	12	4
209		8	43	14	5
210		8	47	14	5
211		8	47	15	6
212		8	50	15	6
213		9	52	15	6
214		9	54	20	6
215		9	54	20	6
216		10	55	20	8
217		10	58	20	8
218		11	62	20	10
305		6	37	9	4
306		7	40	11	4
307		8	46	12	5
308		8	48	13	5
309		8	48	14	6
310		9	52	15	6
311		10	55	16	8
312		10	56	17	8
313		11	56	17	10
314		11	62	20	10
315		11	65	20	10
316		11	70	22	10
317		11	70	22	11
318		12	78	24	10
319		12	80	24	10
320		14	85	26	13
321		14	85	26	13
322		14	90	29	13
324		14	95	34	13
326		15	105	39	13
328		17	120	42	16

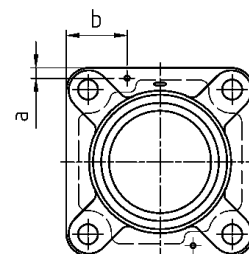
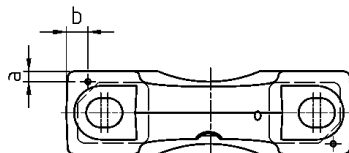

Gehäusefixierung

Gehäuse Bezeichnung	Maße [mm]					
	FLE	a	b	Gehäuse dicke	Empf. Stift-Ø	Zentrier-Ø C ^{+0,2}
203	28,0	14,0	8,0	3	44,80	3,2
204	31,0	14,5	8,5	3	50,80	3,2
205	35,0	16,0	9,0	3	63,50	3,2
206	42,5	17,0	10,0	3	73,00	4,0
207	50,0	17,0	11,0	4	82,50	4,0
208	55,0	19,0	11,0	4	88,90	4,0
209	58,0	21,0	11,0	5	98,42	4,0
210	60,0	22,5	11,0	5	101,60	4,0
211	70,0	26,0	13,0	6	107,95	4,0
212	75,0	26,0	14,0	6	125,40	4,0
213	85,0	28,0	15,0	6	142,00	4,0
214	85,0	28,0	15,0	6	142,00	4,0
215	85,0	30,0	15,0	6	142,00	4,0

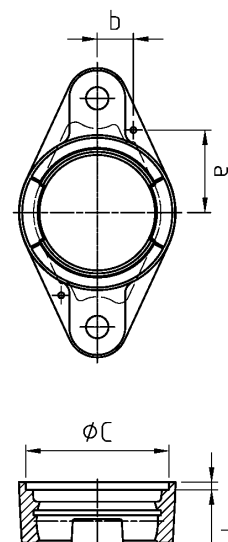

Gehäuse Bezeichnung	Maße [mm]			
	PE	a	b	Empf. Stift-Ø
204	10,0	59,0	14,5	3
205	12,0	59,0	14,5	3
206	13,0	72,0	17,0	3
207	14,5	73,5	19,0	4
208	16,0	81,5	19,0	4
209	16,0	88,0	21,5	5
210	18,0	91,0	21,5	5
211	20,0	101,0	22,5	6
212	20,0	110,0	25,0	6
214	21,5	119,0	27,5	6
215	22,0	121,5	27,5	6
216	26,0	132,0	30,0	8
218	28,5	151,0	35,0	10

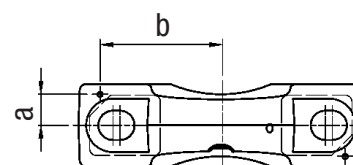

Gehäuse Bezeichnung	Maße [mm]					
	FE	a	b	Gehäuse dicke	Empf. Stift-Ø	Zentrier-Ø C ^{+0,2}
203	32,0	12	9,5	3	44,80	3,2
204	36,0	13	10,0	3	50,80	3,2
205	40,5	15	11,0	3	63,50	3,2
206	46,0	17	12,0	3	76,20	4,0
207	51,0	18	12,5	4	88,90	4,0
208	57,0	20	13,0	4	88,90	4,0
209	60,5	21	13,0	5	98,42	4,0
210	63,5	22	13,0	5	101,60	4,0
211	71,0	25	15,0	6	107,95	4,0
212	77,5	27	16,0	6	125,40	4,0
213	85,0	29	18,0	6	161,92	4,0
214	85,0	29	18,0	6	161,92	4,0
215	88,5	30	20,0	6	161,92	4,0
216	88,5	30	20,0	6	161,92	4,0
218	103,5	36	22,0	6	179,37	4,0

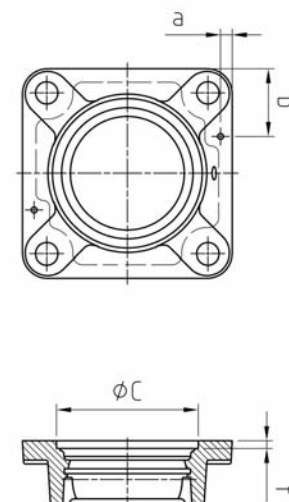



Toleranzen Stahlblechgehäuse

Toleranzen Blechflanschlagergehäuse

Gehäuse			Toleranz [μm]
PF / PFT	PFL	PFE	J
203	203		
204	204		
205	205	205	± 500
206	206	206	
207	207		
208	208		
209			
210			± 1000
211			
212			

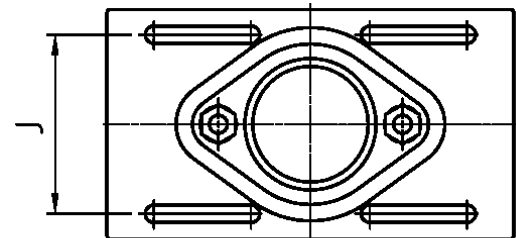
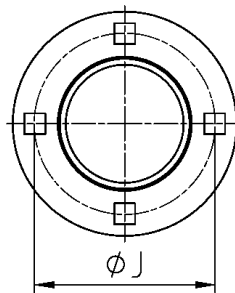
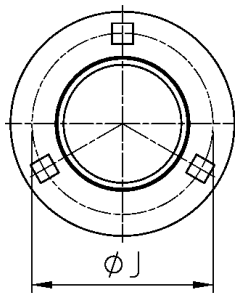
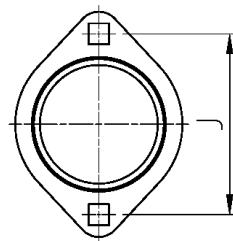
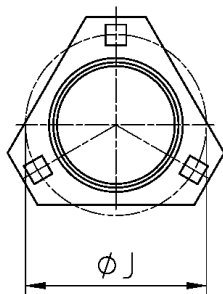

ab Wellen $\text{-}\phi 40$
4 Schraublöcher

Toleranzen Einsätze

Toleranzen Außenring

Nennmaß Außendurchmesser D [mm]		Dmp [μm]		K _{ea} [μm] max.
über	bis	unteres	oberes	
	50	-11	0	20
50	80	-13	0	25
80	120	-15	0	35
120	150	-18	0	40
150	180	-25	0	45
180	250	-30	0	50
250	315	-35	0	60

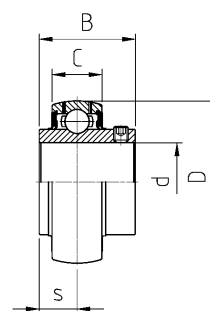

Toleranz Pendelachsabstand

Nennmaß Bohrungsdurchmesser d [mm]		S _{ea} [μm]
über	bis	
	50	±200
50	80	±250
80	120	±300
120	140	±350

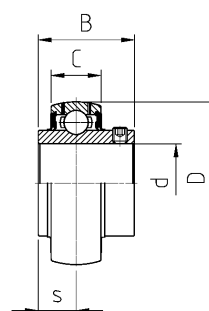

Toleranzen Innenring

CUC/CUS/CES/CEX

Nennmaß Bohrung d [mm]		Δdmp [μm]		K _{ia} [μm] max.	ΔBs [μm]	
über	bis	unteres	oberes		unteres	oberes
	18	+15	0	10	-120	0
18	30	+18	0	10	-120	0
30	50	+21	0	13	-120	0



Toleranzen Innenring

UC/ES/US/EX

Nennmaß Bohrung d [mm]		Δd_{mp} [μm]		K_{ia} [μm]	ΔB_s [μm]	
über	bis	unteres	oberes	max.	unteres	oberes
	18	0	+15	12	-120	0
18	30	0	+18	15	-120	0
30	50	0	+21	18	-120	0
50	80	0	+24	22	-150	0
80	120	0	+28	28	-200	0
120	140	0	+33	35	-250	0

Δd_{mp} = Abweichung des mittleren Bohrungsdurchmessers in einer Ebene

ΔD_{mp} = Abweichung des mittleren Außendurchmessers in einer Ebene

K_{ia} = Rundlauf des Innenringes am zusammengebauten Einsatz

K_{ea} = Rundlauf des Außenringes am zusammengebauten Einsatz

ΔB_s = Abweichung einer einzelnen Innenringbreite

S_{ea} = Planlauf der Stirnseite in Bezug auf die Laufbahn des Außenringes am zusammengebauten Einsatz

Toleranzen Kantenabstände

Nennmaß Kantenabstand e1 [mm]	Bohrungs- durchmesser [mm]		e1 _{min} [mm]		e1 _{max} [mm]	
	über	bis	radial	axial	radial	axial
0,6		40,0	0,6	0,6	1,0	2,0
1,0		50,0	1,0	1,0	1,5	3,0
1,1		120,0	1,1	1,1	2,0	3,5
1,5		120,0	1,5	1,5	2,3	4,0
2,0		80,0	2,0	2,0	3,0	4,5
	80,0				3,5	5,0
2,5		100,0	2,5	2,5	3,8	6,0
3,0		280,0	3,0	3,0	5,0	8,0
4,0			4,0	4,0	6,5	9,0

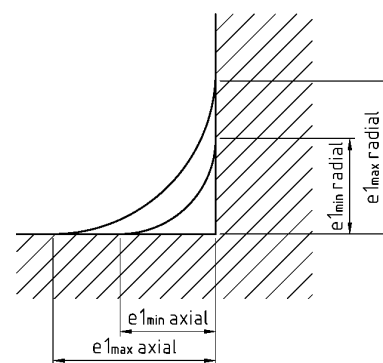

Toleranz kegelige Bohrung

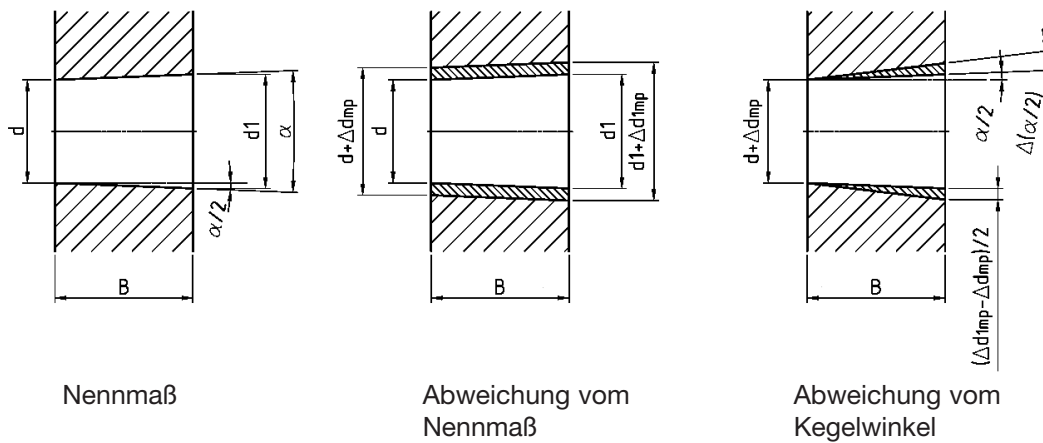

Nennmaß d [mm]		Abmaß			
		Δd_{mp} [μm]		$\Delta d1_{mp} - \Delta d_{mp}$ [μm]	
über	bis	unteres	oberes	unteres	oberes
18	30	0	+33	0	+21
30	50	0	+39	0	+25
50	80	0	+46	0	+30
80	120	0	+54	0	+35
120	180	0	+63	0	+40

- α = Nennwinkel des Kegels = $4^{\circ}46'18,8''$
 $\alpha/2$ = Neigungswinkel am Kegelende = $2^{\circ}23'9,4''$
 $\Delta\alpha/2$ = Abweichung des Neigungswinkels = $1,716 \cdot \frac{\Delta d1_{mp} - \Delta d_{mp}}{B}$ [Minuten]
 B = Breite des Innenringes
 d = Nenndurchmesser der Lagerbohrung
 d1 = Bohrungsdurchmesser am großen Kegelende = $d + 0,083333 \cdot B$
 Δd_{mp} = Abweichung des mittleren Bohrungsdurchmessers in einer Ebene
 $\Delta d1_{mp}$ = Abweichung des Bohrungsdurchmessers d1



Ausführungen

Das SNR-Standardprogramm für Gehäuselager beinhaltet eine große Anzahl an verschiedenen Gehäuselagerausführungen wie z.B. unterschiedliche Bauformen und Werkstoffe. Sollten jedoch für einen besonderen Anwendungsfall die aufgeführten Standardlösungen nicht ausreichen, so hat SNR die Möglichkeit Sonderlösungen zu realisieren.

Die Herstellung aus speziellen Werkstoffen, wie z.B. Sphäroguss oder Stahlguss, spezielle Oberflächenbehandlungen, wie z.B. Verzinken oder Vernickeln, oder aber eine Anpassung der Bauteile an kleinere Bauräume sind Anforderungen, die SNR bereits mehrfach realisiert hat. Eine flexible Fertigung ermöglicht uns die Herstellung kleiner Stückzahlen mit kurzen Lieferzeiten.

SNR verfügt über jahrelange Erfahrungen in der Realisierung von Sonderlösungen. Nachfolgend finden Sie eine kleine Auswahl an Sondergehäuselagern, die in Zusammenarbeit mit unseren Kunden entstanden sind.

Beispiele

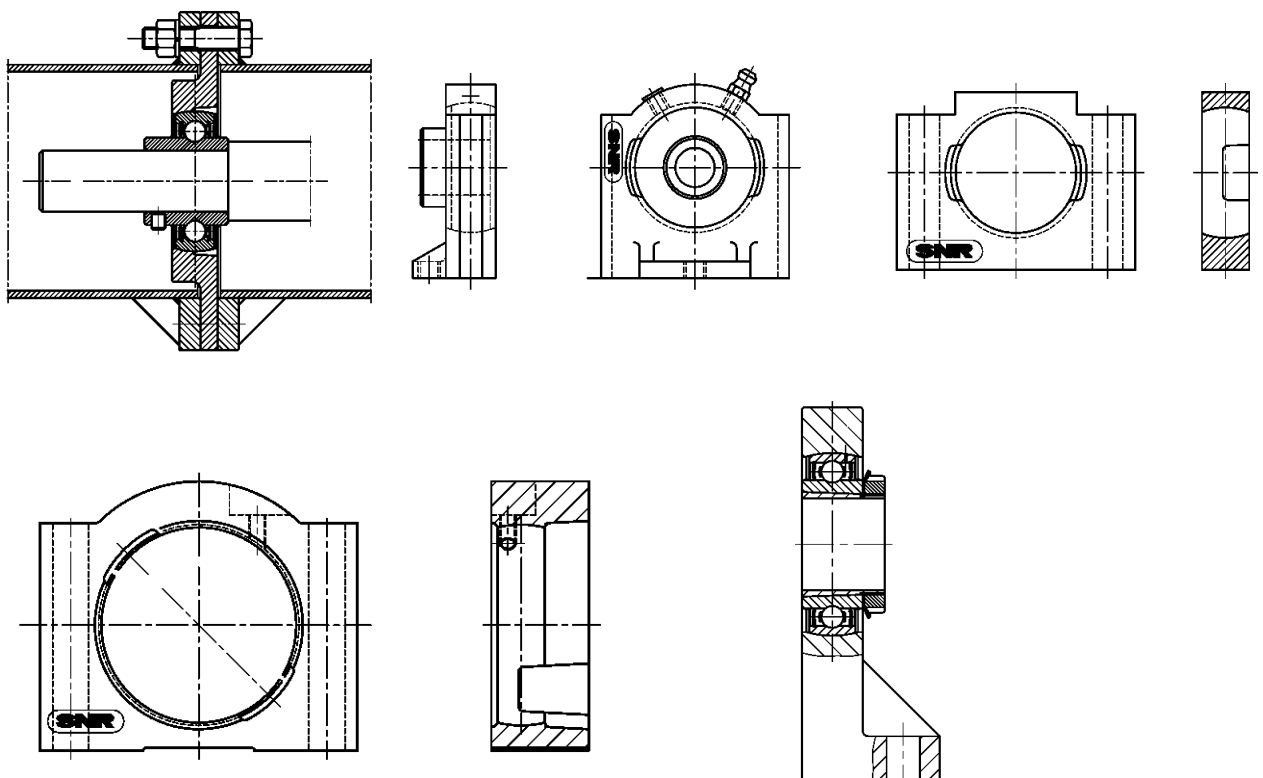

Umrechnungstabellen inch-mm

inch	0	1	2	3	4	5	6	7	8	9	10
0	0	25,400	50,800	76,200	101,600	127,000	152,400	177,800	203,200	228,600	254,000
1/64	0,397	25,797	51,197	76,597	101,997	127,397	152,797	178,197	203,597	228,997	254,397
1/32	0,794	26,194	51,594	76,994	102,394	127,794	153,194	178,594	203,994	229,394	254,794
3/64	1,191	26,591	51,991	77,391	102,791	128,191	153,591	178,991	204,391	229,791	255,191
1/16	1,588	26,988	52,388	77,788	103,188	128,588	153,988	179,388	204,788	230,188	255,588
5/64	1,984	27,384	52,784	78,184	103,584	128,984	154,384	179,784	205,184	230,584	255,984
3/32	2,381	27,781	53,181	78,581	103,981	129,381	154,781	180,181	205,581	230,981	256,381
7/64	2,778	28,178	53,578	78,978	104,378	129,778	155,178	180,578	205,978	231,378	256,778
1/8	3,175	28,575	53,975	79,375	104,775	130,175	155,575	180,975	206,375	231,775	257,175
9/64	3,572	28,972	54,372	79,772	105,172	130,572	155,972	181,372	206,772	232,172	257,572
5/32	3,969	29,369	54,769	80,169	105,569	130,969	156,369	181,769	207,169	232,569	257,969
11/64	4,366	29,766	55,166	80,566	105,966	131,366	156,766	182,166	207,566	232,966	258,366
3/16	4,763	30,163	55,563	80,963	106,363	131,763	157,163	182,563	207,963	233,363	258,763
13/64	5,159	30,559	55,959	81,359	106,759	132,159	157,559	182,959	208,359	233,759	259,159
7/32	5,556	30,956	56,356	81,756	107,156	132,556	157,956	183,356	208,756	234,156	259,556
15/64	5,953	31,353	56,753	82,153	107,553	132,953	158,353	183,753	209,153	234,553	259,953
1/4	6,350	31,750	57,150	82,550	107,950	133,350	158,750	184,150	209,550	234,950	260,350
17/64	6,747	32,147	57,547	82,947	108,347	133,747	159,147	184,547	209,947	235,347	260,747
9/32	7,144	32,544	57,944	83,344	108,744	134,144	159,544	184,944	210,344	235,744	261,144
19/64	7,541	32,941	58,341	83,741	109,141	134,541	159,941	185,341	210,741	236,141	261,541
5/16	7,938	33,338	58,738	84,138	109,538	134,938	160,338	185,738	211,138	236,538	261,938
21/64	8,334	33,734	59,134	84,534	109,934	135,334	160,734	186,134	211,534	236,934	262,334
11/32	8,731	34,131	59,531	84,931	110,331	135,731	161,131	186,531	211,931	237,331	262,731
23/64	9,128	34,528	59,928	85,328	110,728	136,128	161,528	186,928	212,328	237,728	263,128
3/8	9,525	34,925	60,325	85,725	111,125	136,525	161,925	187,325	212,725	238,125	263,525
25/64	9,922	35,322	60,722	86,122	111,522	136,922	162,322	187,722	213,122	238,522	263,922
13/32	10,319	35,719	61,119	86,519	111,919	137,319	162,719	188,119	213,519	238,919	264,319
27/64	10,716	36,116	61,516	86,916	112,316	137,716	163,116	188,516	213,916	239,316	264,716
7/16	11,113	36,513	61,913	87,313	112,713	138,113	163,513	188,913	214,313	239,713	265,113
29/64	11,509	36,909	62,309	87,709	113,109	138,509	163,909	189,309	214,709	240,109	265,509
15/32	11,906	37,306	62,706	88,106	113,506	138,906	164,306	189,706	215,106	240,506	265,906
31/64	12,303	37,703	63,103	88,503	113,903	139,303	164,703	190,103	215,503	240,903	266,303
1/2	12,700	38,100	63,500	88,900	114,300	139,700	165,100	190,500	215,900	241,300	266,700
33/64	13,097	38,497	63,897	89,297	114,697	140,097	165,497	190,897	216,297	241,697	267,097
17/32	13,494	38,894	64,294	89,694	115,094	140,494	165,894	191,294	216,694	242,094	267,494
35/64	13,891	39,291	64,691	90,091	115,491	140,891	166,291	191,691	217,091	242,491	267,891
9/16	14,288	39,688	65,088	90,488	115,888	141,288	166,688	192,088	217,488	242,888	268,288
37/64	14,684	40,084	65,484	90,884	116,284	141,684	167,084	192,484	217,884	243,284	268,684
19/32	15,081	40,481	65,881	91,281	116,681	142,081	167,481	192,881	218,281	243,681	269,081
39/64	15,478	40,878	66,278	91,678	117,078	142,478	167,878	193,278	218,678	244,078	269,478
5/8	15,875	41,275	66,675	92,075	117,475	142,875	168,275	193,675	219,075	244,475	269,875
41/64	16,272	41,672	67,072	92,472	117,872	143,272	168,672	194,072	219,472	244,872	270,272
21/32	16,669	42,069	67,469	92,869	118,269	143,669	169,069	194,469	219,869	245,269	270,669
43/64	17,066	42,466	67,866	93,266	118,666	144,066	169,466	194,866	220,266	245,666	271,066
11/16	17,463	42,863	68,263	93,663	119,063	144,463	169,863	195,263	220,663	246,063	271,463
45/64	17,859	43,259	68,659	94,059	119,459	144,859	170,259	195,659	221,059	246,459	271,859
23/32	18,256	43,656	69,056	94,456	119,856	145,256	170,656	196,056	221,456	246,856	272,256
47/64	18,653	44,053	69,453	94,853	120,253	145,653	171,053	196,453	221,853	247,253	272,653
3/4	19,050	44,450	69,850	95,250	120,650	146,050	171,450	196,850	222,250	247,650	273,050
49/64	19,447	44,847	70,247	95,647	121,047	146,447	171,847	197,247	222,647	248,047	273,447
25/32	19,844	45,244	70,644	96,044	121,444	146,844	172,244	197,644	223,044	248,444	273,844
51/64	20,241	45,641	71,041	96,441	121,841	147,241	172,641	198,041	223,441	248,841	274,241
13/16	20,638	46,038	71,438	96,838	122,238	147,638	173,038	198,438	223,838	249,238	274,638
53/64	21,034	46,434	71,834	97,234	122,634	148,034	173,434	198,834	224,234	249,634	275,034
27/32	21,431	46,831	72,231	97,631	123,031	148,431	173,831	199,231	224,631	250,031	275,431
55/64	21,828	47,228	72,628	98,028	123,428	148,828	174,228	199,628	225,028	250,428	275,828
7/8	22,225	47,625	73,025	98,425	123,825	149,225	174,625	200,025	225,425	250,825	276,225
57/64	22,622	48,022	73,422	98,822	124,222	149,622	175,022	200,422	225,822	251,222	276,622
29/32	23,019	48,419	73,819	99,219	124,619	150,019	175,419	200,819	226,219	251,619	277,019
59/64	23,416	48,816	74,216	99,616	125,016	150,416	175,816	201,216	226,616	252,016	277,416
15/16	23,813	49,213	74,613	100,013	125,413	150,813	176,213	201,613	227,013	252,413	277,813
61/64	24,209	49,609	75,009	100,409	125,809	151,209	176,609	202,009	227,409	252,809	278,209
31/32	24,606	50,006	75,406	100,806	126,206	151,606	177,006	202,406	227,806	253,206	278,606
63/64	25,003	50,403	75,803	101,203	126,603	152,003	177,403	202,803	228,203	253,603	279,003





Umrechnungstabellen mm-inch

mm	10	20	30	40	50	60	70	80	90	
0	0	0,39370	0,78740	1,18110	1,57480	1,96850	2,36220	2,75591	3,14961	3,54331
1	0,03937	0,43307	0,82677	1,22047	1,61417	2,00787	2,40157	2,79528	3,18898	3,58268
2	0,07874	0,47244	0,86614	1,25984	1,65354	2,04724	2,44094	2,83465	3,22835	3,62205
3	0,11811	0,51181	0,90551	1,29921	1,69291	2,08661	2,48031	2,87402	3,26772	3,66142
4	0,15748	0,55118	0,94488	1,33858	1,73228	2,12598	2,51969	2,91339	3,30709	3,70079
5	0,19685	0,59055	0,98425	1,37795	1,77165	2,16535	2,55906	2,95276	3,34646	3,74016
6	0,23622	0,62992	1,02362	1,41732	1,81102	2,20472	2,59843	2,99213	3,38583	3,77953
7	0,27559	0,66929	1,06299	1,45669	1,85039	2,24409	2,63780	3,03150	3,42520	3,81890
8	0,31496	0,70866	1,10236	1,49606	1,88976	2,28346	2,67717	3,07087	3,46457	3,85827
9	0,35433	0,74803	1,14173	1,53543	1,92913	2,32283	2,71654	3,11024	3,50394	3,89764

mm	100	200	300	
0	0	3,93701	7,87402	11,81102
5	0,19685	4,13386	8,07087	12,00787
10	0,39370	4,33071	8,26772	12,20472
15	0,59055	4,52756	8,46457	12,40157
20	0,78740	4,72441	8,66142	12,59843
25	0,98425	4,92126	8,85827	12,79528
30	1,18110	5,11811	9,05512	12,99213
35	1,37795	5,31496	9,25197	13,18898
40	1,57480	5,51181	9,44882	13,38583
45	1,77165	5,70866	9,64567	13,58268
50	1,96850	5,90551	9,84252	13,77953
55	2,16535	6,10236	10,03937	13,97638
60	2,36220	6,29921	10,23622	14,17323
65	2,55906	6,49606	10,43307	14,37008
70	2,75591	6,69291	10,62992	14,56693
75	2,95276	6,88976	10,82677	14,76378
80	3,14961	7,08661	11,02362	14,96063
85	3,34646	7,28346	11,22047	15,15748
90	3,54331	7,48031	11,41732	15,35433
95	3,74016	7,67717	11,61417	15,55118

mm	inch	mm	inch	mm	inch
0,001	0,000039	0,01	0,000394	0,1	0,003937
0,002	0,000079	0,02	0,000787	0,2	0,007874
0,003	0,000118	0,03	0,001181	0,3	0,011811
0,004	0,000157	0,04	0,001575	0,4	0,015748
0,005	0,000197	0,05	0,001969	0,5	0,019685
0,006	0,000236	0,06	0,002362	0,6	0,023622
0,007	0,000276	0,07	0,002756	0,7	0,027559
0,008	0,000315	0,08	0,003150	0,8	0,031496
0,009	0,000354	0,09	0,003543	0,9	0,035433

SNR Gehäuselager Lieferprogramm

SNR - nichtrostende Gehäuselager mit Thermoplast Gehäusen



SNR nichtrostende Gehäuselager
mit Thermoplast Gehäusen

SNR - Industry



Die in diesem Katalog aufgeführten Gehäuselagereinheiten bestehen aus Gehäusen des Werkstoffes Thermoplast PBT und Lagereinsätzen aus rostfreiem Stahl oder Chromstahl.

Die Einheiten können mit Schutzkappen aus SR 50 (Polypropylen), offen mit Zweilippendichtung für durchgehende Wellen oder geschlossen für Wellenenden, ausgerüstet werden.

Die Lagereinheiten finden Verwendung unter anderem in der Lebensmittel- und pharmazeutischen Industrie mit ihren hohen Ansprüchen an Hygiene und Korrosionsbeständigkeit der eingesetzten Werkstoffe. Daher sind alle Gehäuselagereinheiten mit Schmierfett nach USDA H1 - Norm befüllt, welche zur Zeit die strengsten Anforderungen an die Hygiene und Reinheit der im Schmierstoff verwendeten Rohstoffe stellt.

SNR Gehäuselager aus rostfreiem Stahl



SNR Gehäuselager
aus rostfreiem Stahl

SNR - Industry



Gehäuselager aus rostfreiem Stahl finden ihre Anwendung unter anderem in Bereichen, in denen hohe Anforderungen an die Korrosionsbeständigkeit der eingesetzten Bauteile gestellt werden.

In diesen Bereichen mit ihren erschwerten Betriebsbedingungen, wie z. B. hoher Luftfeuchtigkeit oder direktem Kontakt mit aggressiven Medien, können herkömmliche Gehäuselager aus Grauguss die gestellten Anforderungen nur unzulänglich oder gar nicht erfüllen.

Um diesen besonderen Anwendungsfällen Rechnung zu tragen, bietet SNR ein umfangreiches Standardprogramm an Gehäuselagern aus rostfreiem Stahl.

Weiterhin werden die Bedingungen der Arznei- und Lebensmittelindustrie (u. a. hohe Reinheit der im Schmierstoff verwendeten Rohstoffe) nach USDA H1-Norm erfüllt, indem alle SNR-Gehäuselager aus rostfreiem Stahl ausschließlich mit Schmierfett nach dieser Spezifikation befüllt werden.

